

# LEARNING MATERIAL

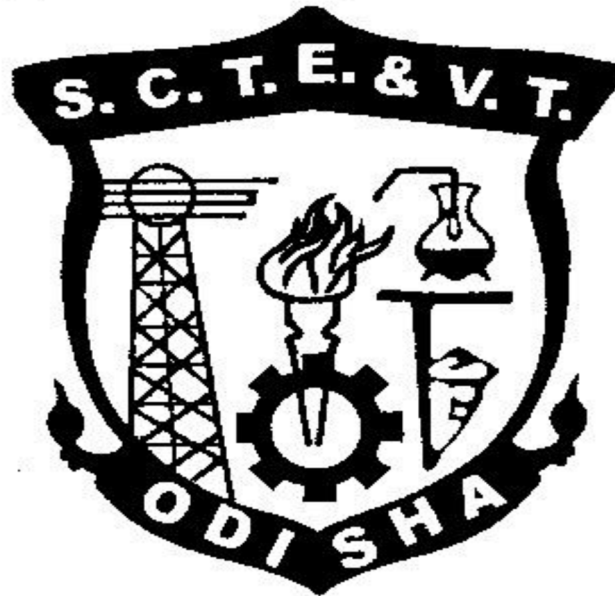

STATE COUNCIL FOR TECHNICAL EDUCATION &  
VOCATIONAL TRAINING, ODISHA, BHUBANESWAR

## FLUID MECHANICS AND HYDRAULIC MACHINES

(For Diploma and Polytechnic students)

# 4<sup>TH</sup> SEMESTER

# CONTENTS

Sl.No.	Chapter	Pages
1	Properties of fluid	3-12
2	Fluid Pressure and its measurements	13-27
3	Hydrostatics	28-39
4	Fluid Flow	40-75
5	Flow through pipe	76-79
6	Impact of jet	80-91
7	Hydraulic turbines	92-112
8	Hydraulic pumps	113-128

## Chapter-1

# Properties of Fluid

### Syllabus:

**1.1 Definitions and Units of Density, Specific weight, specific gravity, specific volume 5**  
**1.2 Definitions and Units of Dynamic viscosity, kinematic viscosity, surface tension, Capillary phenomenon**

### Fluid

#### Definition:

A fluid is a substance which is capable of flowing or a substance which deforms continuously when subjected to external shearing force.

#### Characteristics:

- It has no definite shape of its own but will take the shape of the container in which it is stored.
- A small amount of shear force will cause a deformation.

**Classification:**

A fluid can be classified as follows:

- Liquid
- Gas

**Liquid:**

It is a fluid which possesses a definite volume and assumed as incompressible

**GAS:**

It possesses no definite volume and is compressible.

Fluids are broadly classified into two types.

- Ideal fluids
- Real fluids

**Ideal fluid:**

An ideal fluid is one which has no viscosity and surface tension and is incompressible actually no ideal fluid exists.

**Real fluids:**

A real fluid is one which has viscosity, surface tension and compressibility in addition to the density.

**PROPERTIES OF FLUIDS:****1. density or mass density : (S)**

Density of a fluid is defined as the ratio of the mass of a fluid to its volume. It is denoted by  $\rho$ . The density of liquids are considered as constant while that of gases changes with pressure & temperature variations.

Mathematically

$$\rho = \frac{\text{mass}}{\text{volume}}$$

$$\text{Unit} = \frac{\text{kg}}{\text{m}^3}$$

$$\rho_{water} = 1000 \frac{kg}{m^3}$$

$$\text{or } \frac{gm}{cm^3}$$

2. **Specific weight or weight density((W):**

Specific weight of a fluid is defined as the ratio between the weights of a fluid to its volume. It is denoted by W.

$$\text{Mathematically } W = \frac{\text{weight of fluid}}{\text{volume of fluid}}$$

$$= mg/v$$

$$W = \rho g$$

$$\text{Unit} - \frac{N}{m^3}$$

3. **Specific volume:**

Specific volume of a fluid is defined as the volume of a fluid occupied by a unit mass or volume per unit mass of a fluid is called specific volume.

Mathematically

$$\text{Specific volume} = \frac{\text{Volume of fluid}}{\text{Mass of fluid}} = \frac{1}{\frac{\text{Mass of fluid}}{\text{Volume}}} = \frac{1}{\rho}$$

$$\text{Unit: } \frac{m^3}{kg}$$

4. **Specific gravity:**

Specific gravity is defined as the ratio of the weight density of a fluid to the density or when density standard fluid.

For liquids the standard fluid is water.

For gases the standard fluid is air.

It is denoted by the symbol  $S$

$$\text{Mathematically, } S(\text{for liquids}) = \frac{\text{Weight density (density) of liquid}}{\text{Weight density (density) of water}}$$

$$S(\text{for gases}) = \frac{\text{Weight density (density) of gas}}{\text{Weight density (density) of air}}$$

$$\begin{aligned}\text{Thus weight density of a liquid} &= S \times \text{Weight density of water} \\ &= S \times 1000 \times 9.81 \text{ N/m}^3\end{aligned}$$

$$\begin{aligned}\text{The density of a liquid} &= S \times \text{Density of water} \\ &= S \times 1000 \text{ kg/m}^3.\end{aligned}$$

### Simple Problems:

#### Problem: - 1

Calculate the specific weight, density and specific gravity of one litre of a liquid which weighs 7N.

**Solution.** Given :

$$\text{Volume} = 1 \text{ litre} = \frac{1}{1000} \text{ m}^3 \quad \left( \because 1 \text{ litre} = \frac{1}{1000} \text{ m}^3 \text{ or } 1 \text{ litre} = 1000 \text{ cm}^3 \right)$$

$$\text{Weight} = 7 \text{ N}$$

$$(i) \text{ Specific weight } (w) = \frac{\text{Weight}}{\text{Volume}} = \frac{7 \text{ N}}{\left(\frac{1}{1000}\right) \text{ m}^3} = 7000 \text{ N/m}^3. \text{ Ans.}$$

$$(ii) \text{ Density } (\rho) = \frac{w}{g} = \frac{7000}{9.81} \text{ kg/m}^3 = 713.5 \text{ kg/m}^3. \text{ Ans.}$$

$$(iii) \text{ Specific gravity} = \frac{\text{Density of liquid}}{\text{Density of water}} = \frac{713.5}{1000} \quad \{ \because \text{Density of water} = 1000 \text{ kg/m}^3 \}$$

$$= 0.7135. \text{ Ans.}$$

#### Problem: - 2

Calculate the density, specific weight and specific gravity of one litre of petrol of specific gravity = 0.7

**Solution.** Given :  $\text{Volume} = 1 \text{ litre} = 1 \times 1000 \text{ cm}^3 = \frac{1000}{10^6} \text{ m}^3 = 0.001 \text{ m}^3$

$$\text{Sp. gravity} \quad S = 0.7$$

(i) Density ( $\rho$ )

Using equation (1.1.A),

$$\text{Density } (\rho) = S \times 1000 \text{ kg/m}^3 = 0.7 \times 1000 = 700 \text{ kg/m}^3. \text{ Ans.}$$

(ii) Specific weight ( $w$ )

$$\text{Using equation (1.1),} \quad w = \rho \times g = 700 \times 9.81 \text{ N/m}^3 = 6867 \text{ N/m}^3. \text{ Ans.}$$

(iii) Weight ( $W$ )

$$\text{We know that specific weight} = \frac{\text{Weight}}{\text{Volume}}$$

$$w = \frac{W}{0.001} \text{ or } 6867 = \frac{W}{0.001}$$

$$\therefore W = 6867 \times 0.001 = 6.867 \text{ N. Ans.}$$

**Viscosity:**

Viscosity is defined as the property of a fluid which offers resistance to the movement of one layer of fluid over another adjacent layer of the fluid.

Let two layers of a fluid at a distance  $dy$  apart, move one over the other at different velocities  $u$  and  $u + du$ .

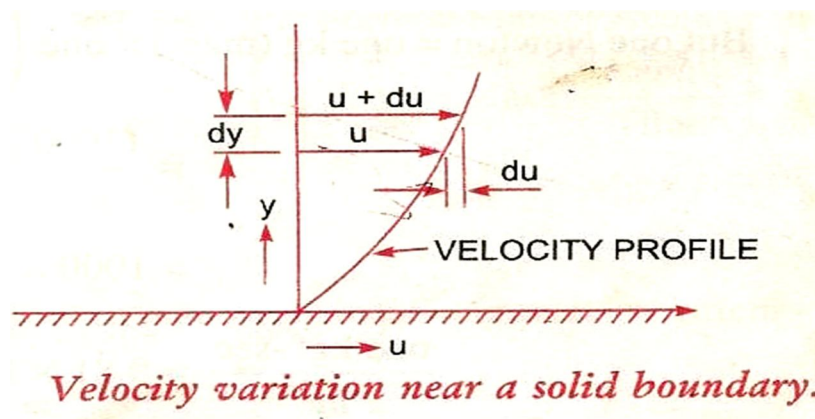

The viscosity together with the with the relative velocity between the two layers while causes a shear stress acting between the fluid layers, the top layer causes a shear stress on the adjacent lower layer while the lower layer causes a shear stress on the adjacent top layer.

This shear stress is proportional to the rate of change of velocity with respect to  $y$ . It is denoted by  $\tau$ .

Mathematically  $\tau \propto \frac{du}{dy}$

$$\tau = \mu \frac{du}{dy}$$

Where  $\mu$  = co-efficient of dynamic viscosity or constant of proportionality or viscosity



$\frac{du}{dy}$  = rate of shear strain or velocity gradient

$$\mu = \frac{\tau}{\frac{du}{dy}}$$

$$\text{If } \frac{du}{dy} = 1,$$

$$\text{then } \mu = \tau$$

Viscosity is defined as the shear stress required to produce unit rate of shear strain.

Unit of viscosity in S.I system -  $\frac{Ns}{m^2}$

in C.G.S -  $\frac{\text{Dyne } s}{cm^2}$

in M.K.S. -  $\frac{kgfs}{m^2}$

$$\frac{\text{Dyne } s}{cm^2} = 1 \text{ Poise}$$

$$1 \frac{Ns}{m^2} = 10 \text{ poise}$$

$$1 \text{ Centipoise} = \frac{1}{100} \text{ poise}$$

**Kinematic Viscosity:**

It is defined as the ratio between the dynamic viscosity and density of fluid.

It is denoted by  $\nu$ .

Mathematically

$$\nu = \frac{\text{Viscosity}}{\text{Density}} = \frac{\mu}{\rho} \quad \dots(1.4)$$

The units of kinematic viscosity is obtained as

$$\begin{aligned} \nu &= \frac{\text{Units of } \mu}{\text{Units of } \rho} = \frac{\text{Force} \times \text{Time}}{(\text{Length})^2 \times \frac{\text{Mass}}{(\text{Length})^3}} = \frac{\text{Force} \times \text{Time}}{\frac{\text{Mass}}{\text{Length}}} \\ &= \frac{\text{Mass} \times \frac{\text{Length}}{(\text{Time})^2} \times \text{Time}}{\left(\frac{\text{Mass}}{\text{Length}}\right)} \quad \left\{ \begin{array}{l} \because \text{Force} = \text{Mass} \times \text{Acc.} \\ = \text{Mass} \times \frac{\text{Length}}{\text{Time}^2} \end{array} \right\} \\ &= \frac{(\text{Length})^2}{\text{Time}} \end{aligned}$$

In MKS and SI, the unit of kinematic viscosity is metre<sup>2</sup>/sec or m<sup>2</sup>/sec while in CGS units it is written as cm<sup>2</sup>/s. In CGS units, kinematic viscosity is also known stoke.

$$\text{Thus, one stoke} = \text{cm}^2/\text{s} = \left(\frac{1}{100}\right)^2 \text{ m}^2/\text{s} = 10^{-4} \text{ m}^2/\text{s}$$

$$\text{Centistoke means} = \frac{1}{100} \text{ stoke.}$$

**Newton's law of viscosity:**

It states that the shear stress on a fluid element layer is directly proportional to the rate of shear strain. The constant of proportionality is called the co-efficient of viscosity.

$$\text{Mathematically} \quad \tau = \mu \frac{du}{dy}$$

Fluids which obey the above equation or law are known as Newtonian fluids & the fluids which do not obey the law are called Non-Newtonian fluids.

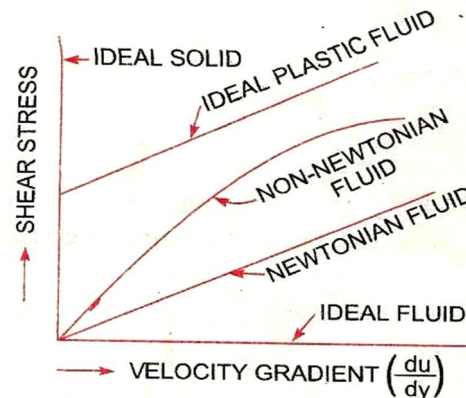

### Surface tension:

Surface tension is defined as the tensile force acting on the surface of a liquid in contact with a gas or on the surface between two immiscible liquids such that the contact surface behaves like a stretched membrane under tension. The magnitude of this force per unit length of the free will has the same value as the surface energy per unit area.

It is denoted by  $\sigma$

Mathematically 
$$\sigma = \frac{F}{L}$$

Unit in si system is N/m

CGS system is Dyne/cm

MKS system is kgf/m

### Capillarity:

Capillarity is defined as a phenomenon of rise or fall of a liquid surface in a small tube relative to the adjacent general level of liquid when the tube is held vertically in the liquid. The rise of liquid surface is known as capillary rise while the fall of the liquid surface is known as capillary depression.

It is expressed in terms of cm or mm of liquid

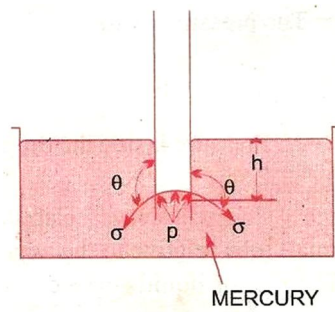
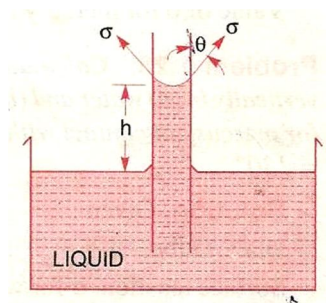

Its value depends upon the specific weight of the liquid, diameter of the tube and surface tension of the liquid.

## Chapter-2

# Fluid Pressure And It's Measurements

### Syllabus:

- 2.1 Definitions and units of fluid pressure, pressure intensity and pressure head**
- 2.2 Concept of atmospheric pressure, gauge pressure, vacuum pressure and absolute pressure**
- 2.3 Pressure measuring instruments Manometers: Simple and differential Bourdon tube pressure gauge (Simple Numerical)**

### Pressure of a Fluid:

When a fluid is contained in a vessel, it exerts force at all points on the sides & bottoms of the container. The force exerted per unit area is called pressure.

If  $P$  = Pressure at any point

$F$  = Total force uniformly distributed over an area

$A$  = unit area

$P = F/A$

Unit of pressure -  $\frac{kgf}{m^2}$  in M.K.S.

-  $\frac{N}{m^2}$  in S.I.

-  $\frac{Dyne}{cm^2}$

1 pascal = 1 N/m<sup>2</sup>

1 kpa = 1000 N/m<sup>2</sup>

### **Pressure head of a liquid:**

A liquid is subjected to pressure due to its own weight, this pressure increases as the depth of the liquid increases.

Let a bottomless cylinder stand in the liquid

Let  $w$  = specific weight of the liquid.

$H$  = height of the liquid in the cylinder.

$A$  = Area of the cylinder.

$$P = \frac{F}{A} = \frac{\text{weight of the liquid in the cylinder}}{\text{Area of the cylinder}}$$

$$= \frac{W \times A h}{A}$$

$$= Wh$$

$$= \rho gh$$

So intensity of pressure at any point in a liquid is proportional to its depth.

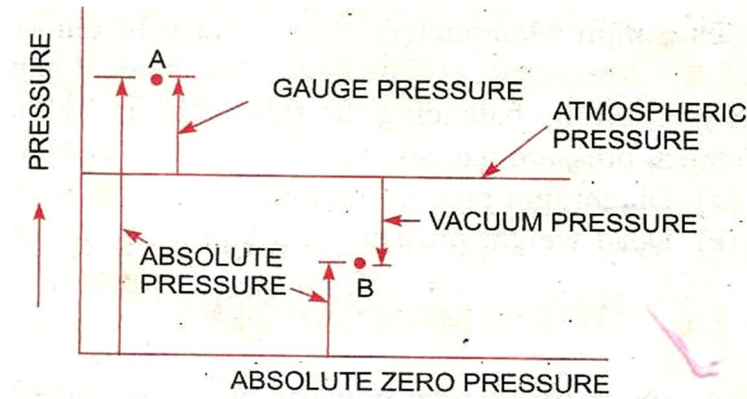
**ABSOLUTE, GAGUE, ATOMOSPHERIC, AND VACCUME PRESSURES:****Atmospheric Pressure:**

The atmospheric air exerts a normal pressure upon all surfaces with which it is in contact & known as atmospheric pressure.

**Absolute pressure:**

It is defined as the pressure which is measured with reference to absolute vacuum pressure or absolute zero pressure.

**Gauge pressure:**

It is defined as the pressure which is measured with the help of a pressure measuring instrument in which the atmospheric pressure is taken as datum. The atmospheric pressure on the scale is marked as zero.

**Vacuum pressure:**

It is defined as the pressure below the atmospheric pressure.

Mathematically:

$$\text{Absolute pressure} = \text{Atmospheric pressure} + \text{gauge pressure}$$

$$\text{Or } P_{\text{abs}} = P_{\text{atm}} + P_{\text{gauge}}$$

$$\text{Vacuum pressure} = \text{Atmospheric pressure} - \text{Absolute pressure}$$

$$P_{\text{vacuum}} = P_{\text{atm}} - P_{\text{abs}}$$

### **Pressure Measuring Instruments:**

The pressure of a fluid is measured by the following devices :

1. **Manometers**
2. **Mechanical Gauges.**

### **Manometers:**

Manometers are defined as the device used for measuring the pressure at a point in a fluid by balancing the column of fluid by the same another column of the fluid. They are classified as:

- (a) **Simple manometers.**
- (b) **Differential Manometers.**

### **Mechanical Gauges:**

Mechanical gauges are defined as the device used for measuring the pressure by balancing the fluid column by the spring or dead weight. Commonly used mechanical pressure gauges are :

- **Diaphragm pressure gauge**
- **Bourdon tube pressure gauge**
- **Dead –weight pressure gauge**
- **Bellow pressure gauge**

### **Simple Manometres:**

A simple manometer of a glass tube having one of its ends connected to a point where pressure is to be measured and other end remains open to atmosphere. Common types of simple manometers are :

- **Piezometer**
- **U- tube Manometer**
- **Single Column Manometer**

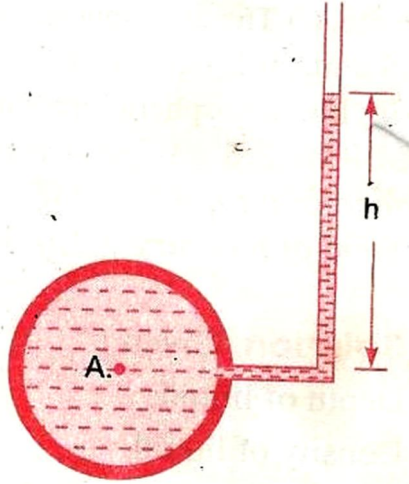

**Piezometer:**

It is the simple form of manometer used for measuring gauge pressures. One end of this manometer is connected to the point where pressure is to be measured and other end is open to the atmosphere as shown in Figure. The rise of liquid gives the pressure head at that point A. Then pressure at A

$$P_A = \rho gh$$

**U – tube Manometer:**

It consist of glass tube bent in U- shape , one end of which is connected to a point at which pressure is to be measured and other end remains open to the atmosphere as shown in figure. The tube generally contains mercury.

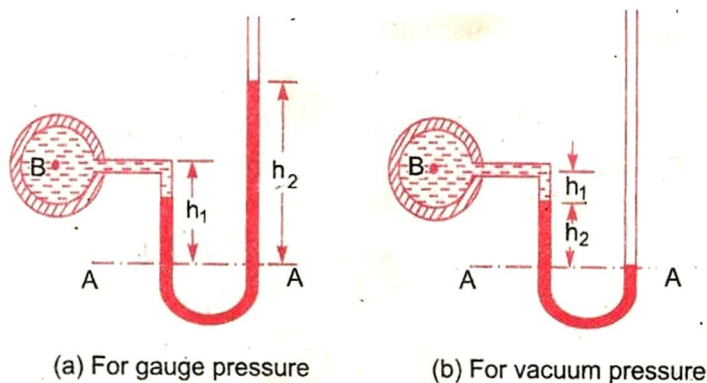

**(a) For Gauge Pressure:**

Let  $p$  be the point which is to be measured, whose value is  $p$ . The datum line is A-A.

Let  $h_1$  = Height of light liquid above the datum line

$h_2$  = Height of heavy liquid above the datum line

$S_1$  = Sp. gr. of light liquid

$\rho_1$  = Density of light liquid =  $1000 \times S_1$

$S_2$  = Sp. Gr. Of heavy weight

$\rho_2$  = density of heavy weight =  $1000 \times S_2$

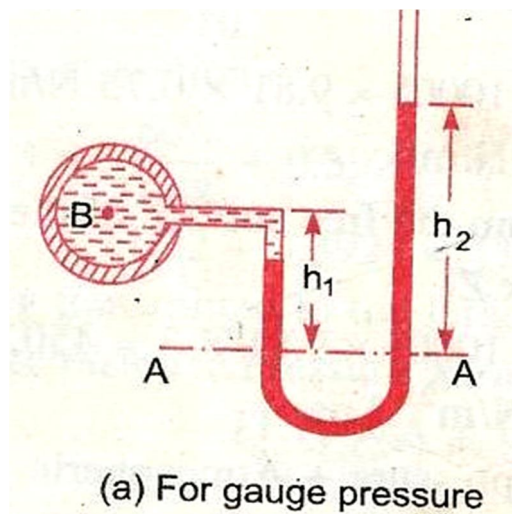

Pressure is same in a horizontal surface. Hence pressure above the horizontal datum surface line A-A in the left column and in the right column of U-tube manometer should be same pressure above A-A in the left column

$$= p_A + \rho_1 \times g \times h_1$$

Pressure above A-A in the right column

$$= \rho_2 \times g \times h_2$$

Hence equating the two pressures

$$p_A + \rho_1 g h_1 = \rho_2 g h_2$$

$$p_A = (\rho_2 g h_2 - \rho_1 g h_1).$$

**(b) For Vacuum Pressure:**

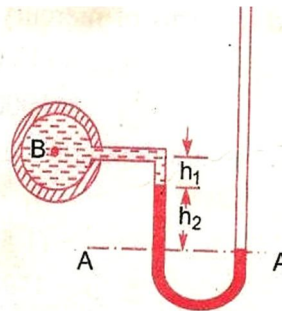

For measuring vacuum pressure, the level of the heavy liquid in the manometer will be as shown in figure. Then Pressure above A-A in the left column

$$= \rho_2 g h_2 + \rho_1 g h_1 + p_A$$

Pressure head in the right column above A - A = 0

$$\rho_2 g h_2 + \rho_1 g h_1 + p_A = 0$$

$$p_A = - (\rho_2 g h_2 + \rho_1 g h_1)$$

### **Single Column Manometer:**

Single column Manometer is modified form of a U- tube manometer in which a reservoir, having a large cross- sectional area (about 100 times as compared to the area of the tube) is connected to one of the limbs (say left limb) of the manometer as shown in figure. Due to large cross- sectional area of the reservoir, for any variation in pressure, the change in the liquid level in the reservoir will be very small which may be neglected and hence the pressure is given by the height of liquid in the other limb. The other limb may be vertical or inclined. Thus there are two types of single column manometer as:

- **Vertical Single Column Manometer**
- **Inclined Single Column Manometer**

### 1. Vertical Single Column Manometer:

Let X-X be the datum line in the reservoir and in the right limb of the manometer, when it is not connected to the pipe. When the manometer is connected to the pipe, due to high pressure at A, the heavy liquid in the reservoir will be pushed downward and will rise in the right limb.

Let  $\Delta h$  = Fall of heavy liquid in reservoir

$H_2$  = rise of heavy liquid in right limb

$H_1$  = height of center of pipe above X-X

$P_A$  = Pressure at A, which is to be measured

$A$  = Cross – sectional area of the reservoir

$a$  = Cross sectional area of the right limb

$S_1$  = Sp.gr.of liquid in pipe

$S_2$  = Sp.gr. of heavy weight liquid in reservoir and right limb

$P_1$  = Density in liquid in pipe

$P_2$  = Density of liquid in the reservoir

Fall of heavy liquid in the reservoir will cause a rise of heavy liquid level in the right limb.

$$\therefore A \times \Delta h = a \times h_2$$

$$\therefore \Delta h = \frac{a \times h}{A} \dots\dots\dots (i)$$

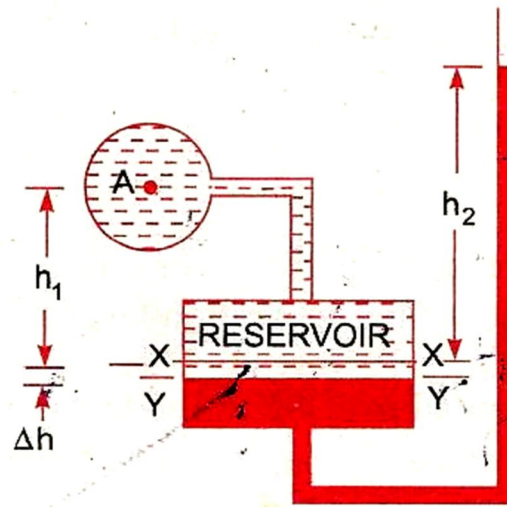

Now consider the datum line Y-Y as shown in Fig 2.15. Then pressure in the right limb above Y-Y.

$$= \rho_2 \times g \times (\Delta h + h_2)$$

Pressure in left limb above Y-Y =  $\rho_1 \times g \times (\Delta h + h_1) + p_A$

Equating the pressure, we have

$$\rho_2 \times g \times (\Delta h + h_2) = \rho_1 \times g \times (\Delta h + h_1) + P_A$$

$$P_A = \rho_2 g (\Delta h + h_2) - \rho_1 g (\Delta h + h_1)$$

$$= \Delta h [\rho_2 g - \rho_1 g] + h_2 \rho_2 g - h_1 \rho_1 g$$

But from equation (i),  $\Delta h = \frac{a \times h}{A}$

$$\text{So, } P_A = \frac{a \times h}{A} [\rho_2 g - \rho_1 g] + h_2 \rho_2 g - h_1 \rho_1 g$$

As the area A is very large as compared to a, hence ratio  $\frac{a}{A}$  becomes very small and can be neglected.

$$\text{Then } P_A = h_2 \rho_2 g - h_1 \rho_1 g$$

## 2. Inclined Single Column Manometer:

The given figure shows the inclined single column manometer which is more sensitive. Due to inclination the distance moved by the heavy liquid in the right limb will be more.

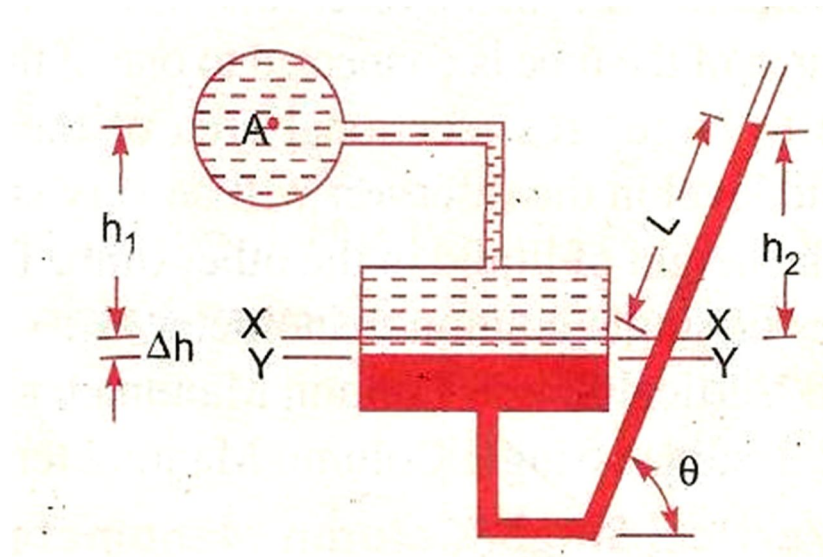

Let  $L$  = length of heavy liquid moved in right limb from X-X

$\theta$  = Inclination of right limb with horizontal

$h_2$  = Vertical rise of heavy liquid in right limb from X-X

$$= L \times \sin\theta$$

From the above equation for the pressure in the single column manometer the pressure at A is

$$P_A = h_2 \rho_2 g - h_1 \rho_1 g .$$

Substituting the value of  $h_2$ , we get

$$P_A = \sin\theta \rho_2 g L - h_1 \rho_1 g .$$

**DIFFERENTIAL MANOMETERS:**

Differential manometers are the device use for measuring the difference of pressures between two points in a pipe or in two different pipes. A differential manometer consists of a U- tube, containing a heavy liquid, whose two ends are connected to the points, whose difference of pressure is to be measured. Most commonly used differential manometers are :

1. **U-tube differential manometer**
2. **Inverted U-tube differential manometer**

**U-tube differential manometer:****Two points A and B are at different level**

The given figure shows the differential manometers of U-tube type.

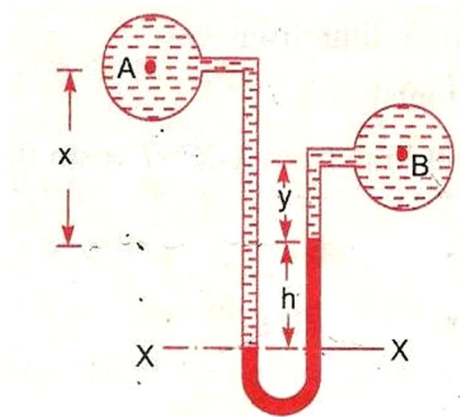

Let the two points A and B are at different level also contains liquids of different sp.gr. These points are connected to the U-tube differential manometer. Let the pressure at A and B are  $P_A$  and  $P_B$ .

Let  $h$  = Difference of mercury level in the U- tube.

$y$  = Distance of the center of B, from the mercury level in the right limb.

$\rho_1$  = Density of liquid at A.

$\rho_2$  = Density of liquid at B.

$\rho_g$  = Density of heavy liquid or mercury.

Taking datum line at X-X .

Pressure above X-X in the limb

$$= \rho_1 g(h + x) + P_A$$

Where pressure  $P_A$  = Pressure at A.

Pressure above X-X in the right limb

$$= \rho_g \times g \times h + \rho_2 \times g \times y + p_B$$

Where pressure  $p_B$  = pressure at B.

Equating the two pressure, we have

$$P_1 g(h + x) + P_A = \rho_g \times g \times h + \rho_2 g y + p_B$$

$$\therefore P_A - p_B = \rho_g \times g \times h + \rho_2 g y - \rho_1 g (h + x)$$

$$= h \times g(\rho_g - \rho_1) + \rho_2 g y - \rho_1 g x$$

$$\therefore \text{Different of pressure at A and B}$$

$$= h \times g(\rho_g - \rho_1) + \rho_2 g y - \rho_1 g x$$

### **Two points A and B are at same level**

In the given figure A and B are the same level and contains the same liquid of density  $\rho_1$ , then

Pressure above X-X in right limb

$$= \rho_g \times g \times h + \rho_1 \times g \times X + p_B$$

Pressure above X-X in left limb

$$= P_1 \times g \times (h + x) + P_A$$



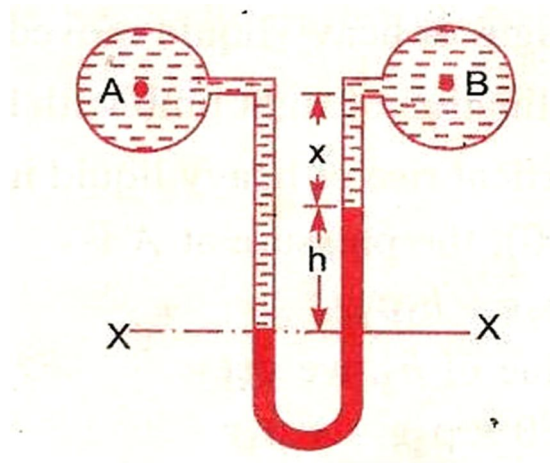

Equating the two pressure

$$P_g \times g \times h + P_1 \times g \times X + P_B = P_1 \times g \times (h + X) + P_A$$

$$\begin{aligned} \therefore P_A - P_B &= P_g \times g \times h + P_1 g X - P_1 g \times (h + X) \\ &= g \times h (P_g - P_1) \end{aligned}$$

**Inverted U-tube Differential Manometer:**

It consists of an inverted U-tube, containing a light liquid. The two ends of the U-tube are connected to the points whose difference of pressure is to be measured. It is used for measuring difference of low pressures. Fig 2.21 shows an inverted U-tube differential manometer connected to the points A and B. Let the pressure at A is more than the pressure at B.

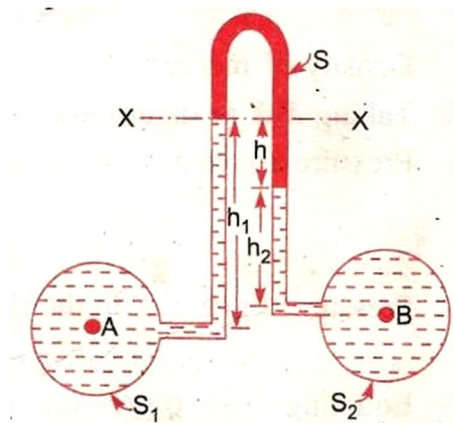

Let  $h_1$  = Height of liquid in the left limb below the datum line X-X

$h_2$  = Height of liquid in the right limb

$h$  = Difference of light liquid

$\rho_1$  = Density of liquid at A

$\rho_2$  = Density of liquid at B

$\rho_s$  = Density of light liquid

$p_A$  = Pressure at A

$p_B$  = Pressure at B.

Taking X-X datum line.

Then pressure in the left limb below X-X

$$= P_A - \rho_1 \times g \times h_1.$$

Pressures in the right limb below X-X

$$= P_B - \rho_2 \times g \times h_2 - \rho_s \times g \times h$$

Equating the two pressure

$$P_A - \rho_1 \times g \times h_1 = P_B - \rho_2 \times g \times h_2 - \rho_s \times g \times h$$

$$P_A - P_B = \rho_1 \times g \times h_1 - \rho_2 \times g \times h_2 - \rho_s \times g \times h$$

### **Bourdon's Tube Pressure Gauge:**

- The pressure above or below the atmospheric pressure may be easily measured with the help of Bourdon tube pressure gauge.
- It consists of an elliptical tube ABC bent into an arc of a circle. This bent up tube is called Bourdon tube.
- When the gauge tube is connected to the C, the fluid under pressure flows into the tube the Bourdon tube as a result of the increased pressure tends to straighten itself.
- Since the tube is encased in a circular cover therefore it tends to become circular instead of straight.
- The elastic deformation of the Bourdon rotates the pointer.
- The pointer moves over a calibrated scale which directly gives the pressure.

**Numerical problems:**

**Q.1** The right limb of a simple U-tube manometer containing mercury is open to the atmosphere while the left limb is connected to a pipe in which a fluid of sp. gravity 0.9 is flowing. The centre of the pipe is 12cm below the level of mercury in the right limb. Find the pressure of fluid in the pipe if the difference of mercury level in the two limbs is 20 cm.

**Q.2** A single column manometer is connected to a pipe containing a liquid of sp. Gravity 0.9 find the pressure in the pipe if the area of the reservoir is 100 times the area of the tube for manometer reading. The sp. Gravity of mercury is 13.6 .

**Q.3** a differential manometer is connected at the two points A and B of two pipes. The pipe A contains a liquid of sp. Gravity =1.5 while pipe B contains a liquid of sp. Gravity 0.9 the pressure at A and B are  $1 \text{ kg/cm}^2$  and  $1.80 \text{ kg/cm}^2$  respectively. Find the difference in mercury level in the differential manometer.

**Q.4** water is flowing through two pipes to which an inverted differential manometer having an oil of sp. Gravity 0.8 is connected. The pressure head in the pipe A is 2m of water, find the pressure in the pipe B for the manometer readings.

# Chapter-3

## Hydrostatics

### Syllabus:

- 3.1 Definition of hydrostatic pressure**
- 3.2 Total pressure and centre of pressure on immersed bodies (Simple Numericals)**
- 3.3 Archimedis' principle, concept of buoyancy, metacentre and metacentric height**
- 3.4 Concept of floatation**

### Hydrostatics:

Hydrostatics means the study of pressure exerted by the liquid at rest & the direction of such a pressure is always right angle to the surface on which it acts.

### Total pressure and center of pressure:

#### Total pressure

Total pressure is defined as the force exerted by a static fluid on a surface either plane or curved when the fluid comes in contact with surfaces. This force always acts normal to the surface.

**Center of pressure:**

Center of pressure is defined as the point of application of the total pressure on the surface.

There are four cases of submerged surfaces on which the total pressure force and center of pressure is to be determined. The submerged surfaces may be:

1. **Vertical plane surface**
2. **Horizontal plane surface**
3. **Inclined plane surface**
4. **Curved surface.**

**Vertical plane surface submerged in liquid**

Consider a plane vertical surface of arbitrary shape immersed in a liquid as shown in figure

Let  $A$  = total area of the surface

$H$  = distanced of C.G. of the area from free surface of liquid

$G$  = center of gravity of plane surface

$P$  = center of pressure

$h^*$  = distance of center of pressure from free surface of liquid.

**Total pressure(F):**

The total pressure on the surface may be determined by dividing the entire surface into a number of small parallel strips. The force on surface is then calculated by integrating the force on small strip.

Consider a strip of thickness  $dh$  & width  $b$  at a depth of  $h$  from free surface of liquid.

Pressure intensity on the strip

$$p = \rho gh$$

Area of the strip,  $dA = b \times dh$

Total pressure force on strip,  $dF = \rho dA$

$$= \rho gh \times b \times dh$$

Total pressure force on the whole surface

$$F = \int dF = \int \rho gh \times b \times dh$$

$$= \rho g \int h \times b \times dh$$

$\int h \times dA =$  moment of surface area about the free surface of liquid

$=$  Area of surface  $\times$  distance of C.G. from the free surface

$$= A \times \bar{h}$$

So,  $F = \rho g A \bar{h}$

### Centre of the pressure: ( $h^*$ )

Centre of pressure is calculated by using the principle of moments which states that the moment of resultant force about an axis is equal to the sum of moments of the components about the same axis.

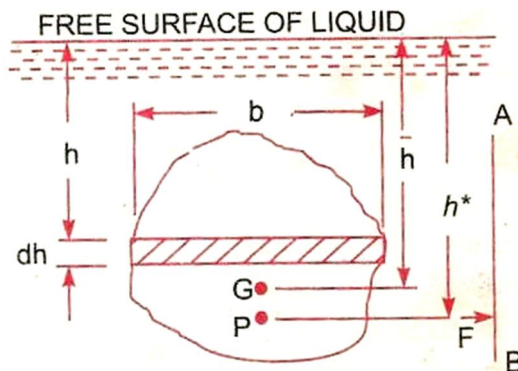

The resultant force  $F$  is acting at  $P$ , at a distance  $h^*$  from the free surface of liquid.

Hence moment of force  $F$  about free surface of liquid  $= F \times h^*$

But moment force  $dF$  acting on a strip about the free surface of liquid =  $dF \times h$

Sum of moments of all such forces about free surface of liquid

$$\begin{aligned} &= \int \rho g h \times b \times dh \times h \\ &= \rho g \int h \times b \times dh \times h \\ &= \rho g \int b h^2 dh \\ &= \rho g \int h^2 dA \end{aligned}$$

$\int h^2 dA$  = moment of inertia of the surface area about the free surface of liquid =  $I_o$

Sum of the moments about free surface

$$= \rho g I_o$$

$$F \times h^* = \rho g I_o$$

$$\rho g A \bar{h} \times h^* = \rho g I_o$$

$$\begin{aligned} h^* &= \frac{\rho g I_o}{\rho g A \bar{h}} \\ &= \frac{I_o}{A \bar{h}} \end{aligned}$$

By the parallel axis theorem, we have

$$I_o = I_G + A \times (\bar{h})^2$$

$$h^* = \frac{I_G + A \bar{h}^2}{A \bar{h}} = \frac{I_G}{A \bar{h}} + \bar{h}$$

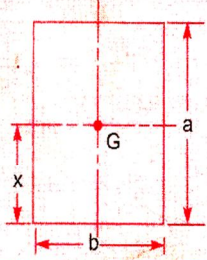
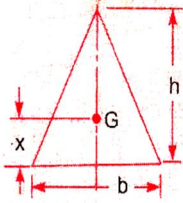
Plane surface	C.G. from the base	Area	Moment of inertia about an axis passing through C.G. and parallel to base ( $I_G$ )	Moment of inertia about base ( $I_0$ )
<p>1. Rectangle</p> 	$x = \frac{d}{2}$	$bd$	$\frac{bd^3}{12}$	$\frac{bd^3}{3}$
<p>2. Triangle</p> 	$x = \frac{h}{3}$	$\frac{bh}{2}$	$\frac{bh^3}{36}$	$\frac{bh^3}{12}$

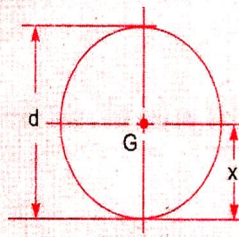
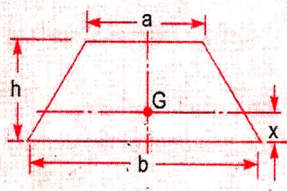
Plane surface	C.G. from the base	Area	Moment of inertia about an axis passing through C.G. and parallel to base ( $I_G$ )	Moment of inertia about base ( $I_0$ )
<p>3. Circle</p> 	$x = \frac{d}{2}$	$\frac{\pi d^2}{4}$	$\frac{\pi d^4}{64}$	—
<p>4. Trapezium</p> 	$x = \left(\frac{2a+b}{a+b}\right) \frac{h}{3}$	$\frac{(a+b)}{2} \times h$	$\left(\frac{a^2 + 4ab + b^2}{36(a+b)}\right) \times h^3$	—



**Horizontal plane surface submerged in liquid:**

Consider a plane horizontal surface immersed in a static fluid as every point of the surface is at the same depth from the free surface of the liquid, the pressure intensity will be equal on the entire surface.

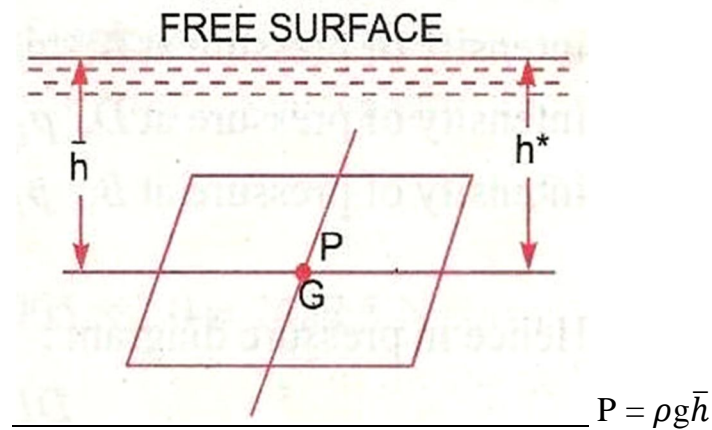

$A$  = total area

$F = P \times A$

$= \rho g A \bar{h}$

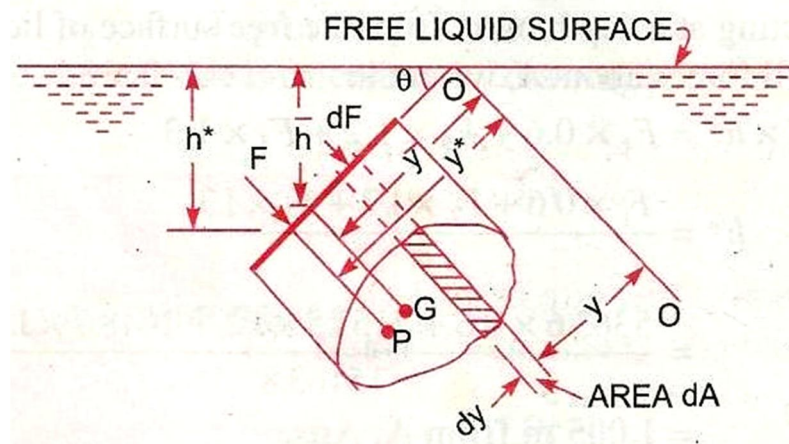
**Inclined plane surface submerged in liquid:**

Let  $A$  = total area of the inclined surface

$H$  = depth of C.G. of inclined area from free surface.

$h^*$  = distance of center of pressure from free surface of liquid.

$\theta$  = *angle* made by the plane of surface with free liquid surface.

Let the plane of the surface if produced meet the free liquid surface at 0. Then 0-0 is the axis parallel to the plane of the surface

$\bar{y}$  = distance of C.G of the inclined surface from 0-0.

$y^*$  = distance of the centre of pressure from 0-0.

Consider a small strip of area  $dA$  at a depth 'h' from free surface & at a distance  $y$  from axis 0-0.

$$P = \rho gh$$

$$dF = p dA$$

$$= \rho gh dA$$

Total pressure force

$$F = \int dF = \int \rho gh dA$$

$$h = y \sin \theta$$

$$F = \int \rho g y \sin \theta dA$$

$$= \rho g \sin \theta \int y dA$$

$$= \rho g \sin \theta I_o$$

$$= \rho g \sin \theta A \bar{y}$$

$$= \rho g A \bar{y} \sin \theta$$

$$= \rho g A \bar{h}$$

**Centre of pressure:**

Pressure force on the strip  $dF = \rho g h \, dA$

$$= \rho g y \sin \theta \, dA$$

Moment of the force  $dF$  about  $O - O$

$$= dF \times y = \rho g y^2 \sin \theta \, dA$$

Sum of moments of all such forces about  $O - O$

$$= \rho g \sin \theta \int y^2 \, dA$$

$\int y^2 \, dA =$  moment of inertia of the surface about  $O - O = I_o$

$$= \rho g \sin \theta \, I_o$$

Moment of total force about  $O - O$

$$= F \, y^*$$

$$F \, y^* = \rho g \sin \theta \, I_o$$

$$\rho g A \bar{h} \times \frac{h^*}{\sin \theta} = \rho g \sin \theta \, I_o$$

$$h^* = \frac{\sin^2 \theta}{A \bar{h}} \, I_o$$

$$= \frac{\sin^2 \theta}{A \bar{h}} [I_G + A \times (\bar{y})^2]$$

Here  $\frac{\bar{h}}{\bar{y}} = \sin \theta$

$$\bar{y} = \frac{\bar{h}}{\sin \theta}$$

$$h^* = \frac{\sin^2 \theta}{A \bar{h}} \left[ I_G + A \times \left( \frac{\bar{h}}{\sin \theta} \right)^2 \right]$$

$$h^* = \frac{I_G \sin^2 \theta}{A \bar{h}} + \bar{h}$$

**Archimedes principle:**

When a body is immersed in a fluid either wholly or partially, it is buoyed or lifted up by a force, which is equal to the weight of fluid displaced by the body.

**Buoyancy:**

Whenever a body is immersed wholly or partially in a fluid it is subjected to an upward force which tends to lift it up. This tendency for an immersed body to be lifted up in the fluid due to an upward force opposite to action of gravity is known as buoyancy this upward force is known as force of buoyancy.

**Centre of Buoyancy:**

It is defined as the point through which the force of buoyancy is supposed to act. The force of buoyancy is a vertical force and is equal to the weight of the fluid displaced by the body.

Center of buoyancy will be the centre of gravity of the fluid displaced.

**Problem-1:**

Find the volume of the water displaced & position of centre of buoyancy for a wooden block of width 2.5m & of depth 1.5m when it floats horizontally in water. The density of wooden block is 650 kg/m<sup>3</sup> & its length 6.0m.

Solution:

Width = 2.5 m

Density of wooden block = 650 kg/m<sup>3</sup>

Depth = 1.5m

Length = 6m

Volume of the block

$$\begin{aligned} &= 2.5 \times 1.5 \times 6 \\ &= 22.50 \text{m}^3 \end{aligned}$$

Volume of the block = Wt of water displaced

$$\begin{aligned} &= W \times V \\ &= \rho g \times V \\ &= 650 \times 9.81 \times 6 \\ &= 143471 \text{ N} \end{aligned}$$

Volume of water displaced

$$\begin{aligned} &= \frac{\text{weight}}{\rho_w \times g} \\ &= \frac{143471}{1000 \times 9.81} \\ &= 14.625 \text{ m}^3 \end{aligned}$$

Position of centre of buoyancy

Volume of wooden block in water = volume of water displaced

$$2.5 \times 6 \times h = 14.625$$

$$\Rightarrow h = \frac{14.625}{2.5 \times 6}$$

$$= 0.975 \text{m}$$

$$\text{Centre of buoyancy} = \frac{0.975}{2}$$

$$= 0.4875 \text{ m from base.}$$

### Meta-centre;

It is defined as the point about which a body starts oscillating when the body is tilted by a small angle. The meta centre may also be defined as the point at which the line of action of the force of buoyancy will meet the normal axis of the body when the body is given a small angular displacement.

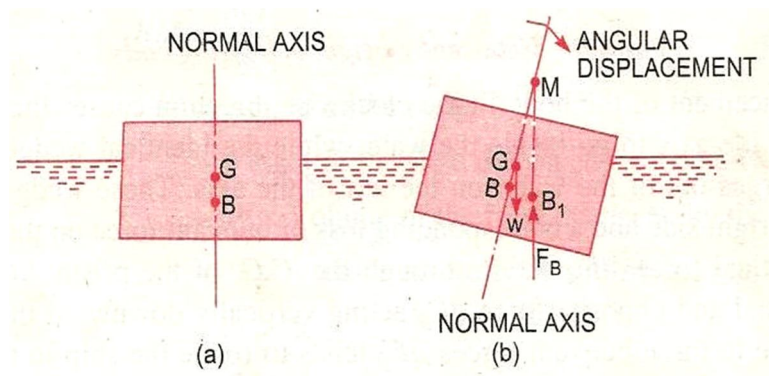

### Meta centre height:

The distance between the meta centre of a floating body and the centre of gravity of the body is called meta-centric height i.e the distance MG.

### Concept of flotation:

#### Flotation:

When a body is immersed in any fluid, it experiences two forces. First one is the weight of body  $W$  acting vertically downwards, second is the buoyancy force  $F_\beta$  acting vertically upwards. In case  $W$  is greater than  $F_\beta$ , the weight will cause the body to sink in the fluid. In case  $W = F_\beta$  the body will remain in equilibrium at any level. In case  $W$  is small than  $F_\beta$  the body will move upwards in fluid. The body moving up will come to rest or top moving up in fluid when the fluid displaced by its submerged part is equal to its weight  $W$ , the body in this situation is said to be floating and this phenomenon is known as flotation.

**Principle of flotation:**

The principle of flotation states that the weight of the floating body is equal to the weight of the fluid displaced by the body.

Consider a body floating at the free surface of the liquid. The shaded part of the body is inside the fluid and it has volume  $V_1$ . The other part of the body is in air and it has volume  $V_2$ . Now the body can be considered to be in two fluids viz. air and liquid. Hence buoyant force

$$F_B = \rho_{\text{liquid}} V_1 g_1 + \rho_{\text{air}} V_2 g_2 = W$$

Since  $\rho_{\text{air}} \ll \rho_{\text{liquid}}$

$$F_B = \rho_{\text{liquid}} V_1 g = W$$

Buoyancy force is equal to weight of the liquid displaced

**The ways to make the body float:**

The body can be made to float:

1. Decreasing the weight of the body while keeping the volume same. For example, making body hollow.
2. Increasing the volume of the body while keeping the body same. For example, attaching life jacket to a person fixed the person floating.

# Chapter-4

## Fluid Flow

### Syllabus:

**4.1 Types of fluid flow**

**4.2 Continuity equation (Statement and proof for one dimensional flow)**

**4.3 Bernoulli's theorem (Statement and proof)**

**Applications and limitations of Bernoulli's theorem  
(Venturimeter, pitot tube)**

**(Simple Numerical)**

**4.4 Definition of orifices, Orifice coefficients ( $C_c$ ,  $C_v$ ,  $C_d$  and relation among them)**

### Introduction:-

This chapter includes the study of forces causing fluid flow. The dynamics of fluid flow is the study of fluid motion with the forces causing flow. The dynamic behaviour of the fluid flow is analysed by the Newton second law of motion, which relates the acceleration with the forces. The fluid is assumed to be incompressible and non-viscous.



**TYPES OF FLOW:-**

The fluid flow is classified as follows:

- **STEADY AND UNSTEADY FLOW**
- **UNIFORM AND NON- UNIFORM FLOWS**
- **LAMINAR AND TURBULANT FLOWS**
- **COMPRESSIBLE AND INCOMPRESSIBLE FLOWS**
- **ROTATIONAL AND IRROTATIONAL FLOWS**
- **ONE, TWO, THREE DIMENSIONAL FLOW**

➤ **STEADY AND UNSTEADY FLOW:-**

1. **Steady flow:-**

Steady flow is defined as that type of flow in which the fluid characteristics like velocity, pressure, density at a point do not change with time.

Thus, mathematically

$$\left(\frac{\partial v}{\partial t}\right)_{x_0, y_0, z_0} = 0$$

$$\left(\frac{\partial p}{\partial t}\right)_{x_0, y_0, z_0} = 0$$

$$\left(\frac{\partial \rho}{\partial t}\right)_{x_0, y_0, z_0} = 0$$

Where  $x_0, y_0, z_0$  is a point in fluid flow .

2. **Unsteady flow:-**

Unsteady flow is defined as that type of flow in which the velocity, pressure, and density at a point changes w.r.t time.

Thus, mathematically

$$\left(\frac{\partial v}{\partial t}\right)_{x_0, y_0, z_0} \neq 0,$$

$$\left(\frac{\partial p}{\partial t}\right)_{x_0, y_0, z_0} \neq 0,$$

$$\left(\frac{\partial \rho}{\partial t}\right)_{x_0, y_0, z_0} \neq 0$$

➤ **UNIFORM AND NON- UNIFORM FLOWS:-**

1. **Uniform flow:-**

It is defined as the flow in which velocity of flow at any given time does not change w.r.t length of flow or space.

Mathematically,

$$\left(\frac{dv}{ds}\right)_{t=constant} = 0$$

where  $dv$  = velocity of flow ,

$ds$  = length of flow ,

T = time

2. **Non- uniform flows:-**

It is defined as the flow in which velocity of flow at any given time changes w.r.t length of flow.

Mathematically,

$$\left(\frac{dv}{ds}\right)_{t=constant} \neq 0$$

➤ **LAMINAR AND TURBULANT FLOWS:-**

1. **Laminar flow:-**

Laminar flow is that type of flow in which the fluid particles are moved in a well defined path called streamlines. The paths are parallel and straight to each other.

2. **Turbulent flow:-**

Turbulent flow is that type of flow in which the fluid particles are moved in a zig-zag manner.

For a pipe flow the type of flow is determined by Reynolds number ( $R_e$ )

Mathematically

$$R_e = \frac{VD}{\nu}$$

Where V = mean velocity of flow

D = diameter of pipe

$\nu$  = kinematic viscosity

If  $R_e < 2000$ , then flow is laminar flow.

If  $R_e > 4000$ , then flow is turbulent flow.

If  $R_e$  lies in between 2000 and 4000, the flow may be laminar or turbulent.

➤ **COMPRESSIBLE AND INCOMPRESSIBLE FLOWS :-**

1. **Compressible flow:-**

Compressible flow is that type of flow in which the density of fluid changes from point to point.

So,  $\rho \neq \text{constant}$ .

2. **Incompressible flow:-**

Incompressible flow is that type of flow in which the density is constant for the fluid flow.

So,  $\rho = \text{constant}$

➤ **ROTATIONAL AND IRROTATIONAL FLOWS:-**

1. **Rotational flow:-**

Rotational flow is that of flow in which the fluid particles while flowing along stream lines also rotate about their own axis.

2. **Ir-rotational flow:-**

Irrotational flow is that type of flow in which the fluid particles while flowing along streamlines do not rotate about their own axis.

➤ **ONE, TWO, THREE DIMENSIONAL FLOW:-**

1. **One dimensional flow:-**

One dimension flow is defined as that type of flow in which velocity is a function of time and one space co-ordinate only.

For a steady one dimensional flow, the velocity is a function of one space co-ordinate only.

$$\text{So, } U = f(x),$$

$$V = 0,$$

$$W = 0$$

U, V, W are velocity components in x, y, z direction respectively.

2. **Two-dimensional flow:-**

Two-dimensional flow is the flow in which velocity is a function of time and 2- space co- ordinates only. For a steady 2- dimensional flow the velocity is a function of two – space co-ordinate only.

$$\text{So, } U = f_1(x,y) ,$$

$$V = f_2(x,y) ,$$

$$W = 0$$

3. **Three-dimensional flow:-**

Three – dimensional flow is the flow in which velocity is a function of time and 3- space co-ordinates only. For steady three- dimensional flow, the velocity is a function of three space co-ordinates only.

So  $U = f_1(x, y, z)$

$$V = f_2(x, y, z)$$

$$W = f_3(x, y, z)$$

### RATE OF FLOW OR DISCHARGE

It is defined as the quantity of a fluid flowing per second through a section of pipe.

For an incompressible fluid the rate of flow or discharge is expressed as the volume of fluid flowing across the section per second.

For compressible fluids, the rate of flow is usually expressed as the weight of fluid flowing across the section.

$$Q = A \cdot V$$

Where  $A$  = cross sectional area of the pipe

$V$  = velocity of fluid across the section

Unit:-

1. For incompressible fluid

$$\frac{m^3}{sec} \text{ or } \frac{litre}{sec}$$

2. For compressible fluid:

$$\frac{newton}{sec} \text{ (S.I units), } \frac{kgf}{sec} \text{ (M.K.S units)}$$

EQUATION OF CONTINUITY:-

It is based on the principle of conservation of mass. For a fluid flowing through the pipe at all the cross-section, the quantity of fluid per second is constant.

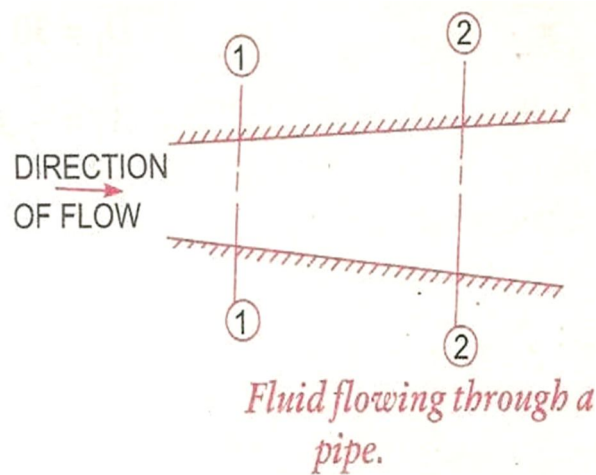

Let  $V_1$  = average velocity at cross-section 1-1.

$\rho_1$  = density at cross-section 1-1

$A_1$  = area of pipe at section 1-1

$V_2$  = average velocity at cross-section 2-2

$\rho_2$  = density at cross-section 2-2

$A_2$  = area of pipe at section 2-2

The rate of flow at section 1-1 =  $\rho_1 A_1 V_1$

The rate of flow at section 2-2 =  $\rho_2 A_2 V_2$

According to laws of conservation of mass rate of flow at section 1-1 is equal to the rate of flow at section 2-2 ,

$$\rho_1 A_1 V_1 = \rho_2 A_2 V_2$$

This is called continuity equation.

If the fluid is compressible, then  $\rho_1 = \rho_2$ ,

$$\text{so } A_1 V_1 = A_2 V_2$$

“If no fluid is added removed from the pipe in any length then the mass passing across different sections shall be same”

### Simple Problems

#### Problem:-1

The diameters of a pipe at the sections 1 and 2 are 10cm and 15cm respectively. Find the discharge through the pipe if the velocity of the water flowing through the pipe at section 1 is 5m/s. Determine also the velocity at section 2.

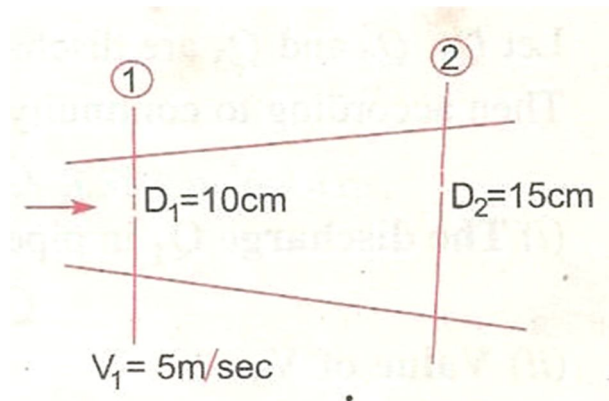

**Solution.** Given :

At section 1,

$$D_1 = 10\text{ cm} = 0.1\text{ m}$$

$$A_1 = \frac{\pi}{4} (D_1)^2 = \frac{\pi}{4} (.1)^2 = .007854\text{ m}^2$$

$$V_1 = 5\text{ m/s.}$$

At section 2,

$$D_2 = 15\text{ cm} = 0.15\text{ m}$$

$$A_2 = \frac{\pi}{4} (.15)^2 = 0.01767\text{ m}^2$$

(i) Discharge through pipe is given by equation (5.1)

or

$$Q = A_1 \times V_1$$

$$= .007854 \times 5 = \mathbf{0.03927\text{ m}^3/\text{s. Ans.}}$$

Using equation (5.3), we have  $A_1 V_1 = A_2 V_2$

$$(ii) \therefore V_2 = \frac{A_1 V_1}{A_2} = \frac{.007854}{.01767} \times 5.0 = \mathbf{2.22\text{ m/s.}}$$

**Problem:-2**

A 30cm diameter pipe conveying water branches into two pipes of diameter 20cm and 15cm respectively. If the average velocity in the 30cm diameter pipe is 2.5 m/s, find the discharge in this pipe. Also determine the velocity in 15cm pipe if the average velocity in 20cm diameter pipe is 2m/s

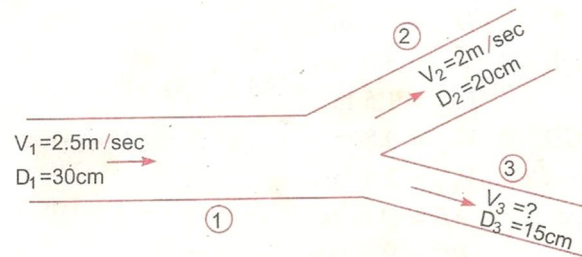
**Solution:****Given Data:**

$$D_1 = 30\text{cm} = 0.30\text{m}$$

$$A_1 = \frac{\pi}{4} D_1^2 = \frac{\pi}{4} (0.3)^2 = 0.07068 \text{ m}^2$$

$$V_1 = 2.5 \text{ m/s}$$

$$D_2 = 20\text{cm} = 0.2\text{m}$$

$$A_2 = \frac{\pi}{4} 0.2^2 = 0.0314 \text{ m}^2$$

$$V_2 = 2\text{m/s}$$

$$D_3 = 15\text{cm} = 0.15\text{m}$$

$$A_3 = \frac{\pi}{4} 0.15^2 = 0.01767 \text{ m}^2$$

Let  $Q_1$ ,  $Q_2$ ,  $Q_3$  are discharges in pipe 1, 2, 3 respectively

$$Q_1 = Q_2 + Q_3$$

The discharge  $Q_1$  in pipe 1 is given as

$$\begin{aligned} Q_1 &= A_1 V_1 \\ &= 0.07068 \times 2.5 \text{ m}^3/\text{s} \end{aligned}$$

$$\begin{aligned} Q_2 &= A_2 V_2 \\ &= 0.0314 \times 2.0 \text{ m}^3/\text{s} \end{aligned}$$



Substituting the values of  $Q_1$  and  $Q_2$  on the above equation we get

$$0.1767 = 0.0628 + Q_3$$

$$Q_3 = 0.1767 - 0.0628 \\ = 0.1139 \text{ m}^3/\text{s}$$

Again  $Q_3 = A_3 V_3$

$$= 0.01767 \times V_3$$

Or  $0.1139 = 0.01767 \times V_3$

$$V_3 = \frac{0.1139}{0.01767}$$

$$= 6.44 \text{ m/s}$$

### **Problem:-3**

Water through a pipe AB 1.2 m diameter at 3 m/s and then passes through a pipe BC 1.5 m diameter. At C, the pipe branches. Branch CD is 0.8 m in diameter and carries one third of the flow in AB. The flow velocity in branch CE is 2.5 m/s. Find the volume rate of flow in AB, the velocity in BC, the velocity in CD and the diameter of CE.

### **Solution:**

Given Data:

$$\text{Diameter of pipe AB, } D_{AB} = 1.2 \text{ m}$$

$$\text{Velocity of flow through AB, } V_{AB} = 3.0 \text{ m/s}$$

Dia, of pipe BC  $D_{BC} = 1.5\text{m}$

Dia of branched pipe CD =  $V_{CD} = 0.8\text{m}$

Velocity of flow in pipe CE,  $V_{CE} = 2.5\text{m/s}$

Let flow rate in pipe AB =  $Q\text{m}^3/\text{s}$

Velocity of flow in pipe BC =  $V_{BC} \text{ m/s}$

Velocity of flow in pipe CD =  $V_{CD}$

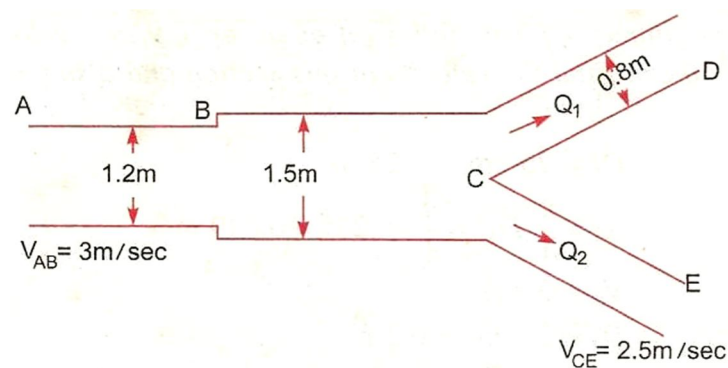

Diameter of pipe  $CE = D_{CE}$

Then flow rate through  $CD = Q/3$

and flow rate through  $CE = Q - Q/3 = \frac{2Q}{3}$

(i) Now volume flow rate through AB =  $Q = V_{AB} \times \text{Area of AB}$

$$\doteq 3.0 \times \frac{\pi}{4} (D_{AB})^2 = 3.0 \times \frac{\pi}{4} (1.2)^2$$

$$= 3.394\text{m}^3/\text{s}$$

(ii) Applying continuity equation to pipe AB and pipe BC,

$$V_{AB} \times \text{Area of pipe AB} = V_{BC} \times \text{Area of pipe BC}$$

$$\text{or} \quad 3.0 \times \frac{\pi}{4} (D_{AB})^2 = V_{BC} \times \frac{\pi}{4} (D_{BC})^2$$

$$\text{or} \quad 3.0 \times (1.2)^2 = V_{BC} \times (1.5)^2$$

$$\text{or} \quad V_{BC} = \frac{3 \times 1.2^2}{1.5^2} = \mathbf{1.92 \text{ m/s. Ans.}}$$

(iii) The flow rate through pipe

$$C_D = Q_1 = \frac{Q}{3} = \frac{3.393}{3} = 1.131 \text{ m}^3/\text{s}$$

$$\therefore Q_1 = V_{CD} \times \text{Area of pipe } C_D \times \frac{\pi}{4} (C_{CD})^2$$

$$\text{or} \quad 1.131 = V_{CD} \times \frac{\pi}{4} \times .8^2 = 0.5026 V_{CD}$$

$$\therefore V_{CD} = \frac{1.131}{0.5026} = \mathbf{2.25 \text{ m/s. Ans.}}$$

(iv) Flow rate through CE,

$$Q_2 = Q - Q_1 = 3.393 - 1.131 = 2.262 \text{ m}^3/\text{s}$$

$$\therefore Q_2 = V_{CE} \times \text{Area of pipe CE} = V_{CE} \frac{\pi}{4} (D_{CE})^2$$

$$\text{or} \quad 2.263 = 2.5 \times \frac{\pi}{4} \times (D_{CE})^2$$

$$\text{or} \quad D_{CE} = \sqrt{\frac{2.263 \times 4}{2.5 \times \pi}} = \sqrt{1.152} = 1.0735 \text{ m}$$

$\therefore$  Diameter of pipe CE = **1.0735 m. Ans.**

**Problem:-4**

A 25 cm diameter pipe carries oil of sp. Gr. 0.9 at a velocity of 3m/s. At another section the diameter is 20cm. Find the velocity at this section and also mass rater of flow of oil.

**Solution.** Given :

at section 1,

$$D_1 = 25 \text{ cm} = 0.25 \text{ m}$$

$$A_1 = \frac{\pi}{4} D_1^2 = \frac{\pi}{4} \times .25^2 = 0.049 \text{ m}^2$$

$$V_1 = 3 \text{ m/s}$$

at section 2,

$$D_2 = 20 \text{ cm} = 0.2 \text{ m}$$

$$A_2 = \frac{\pi}{4} (.2)^2 = 0.0314 \text{ m}^2$$

$$V_2 = ?$$

Mass rate of flow of oil = ?

Applying continuity equation at sections 1 and 2,

$$A_1 V_1 = A_2 V_2$$

or  $0.049 \times 3.0 = 0.0314 \times V_2$

$$\therefore V_2 = \frac{0.049 \times 3.0}{.0314} = \mathbf{4.68 \text{ m/s. Ans.}}$$

Mass rate of flow of oil = Mass density  $\times Q = \rho \times A_1 \times V_1$

Sp. gr. of oil =  $\frac{\text{Densit of oil}}{\text{Densit of water}}$

$\therefore$  Density of oil = Sp. gr. of oil  $\times$  Density of water

$$= 0.9 \times 1000 \text{ kg/m}^3 = \frac{900 \text{ kg}}{\text{m}^3}$$

$\therefore$  Mass rate of flow =  $900 \times 0.049 \times 3.0 \text{ kg/s} = \mathbf{132.23 \text{ kg/s. Ans.}}$

**Bernoulli's equation:**

**Statement:** It states that in a steady ideal flow of an incompressible fluid, the total energy at any point of flow is constant.

The total energy consists of pressure energy, kinetic energy & potential energy or datum energy. These energies per unit weight are

$$\text{Pressure energy} = \frac{P}{\rho g}$$

$$\text{Kinetic energy} = \frac{v^2}{\rho g}$$

$$\text{Datum energy} = z$$

Mathematically

$$\frac{P}{\rho g} + \frac{v^2}{\rho g} + z = \text{Constant}$$

**Derivation:**

Consider a perfect incompressible liquid, flowing through a non-uniform pipe the pipe is running full & there

Let us consider two sections AA & BB of the pipe

Now assume that the pipe is running full & there is a continuity of flow between the two sections

Let  $Z_1$  = Height of AA

$P_1$  = Pressure of AA

$V_1$  = Velocity of liquid of AA

$Q_1$  = Cross sectional area of the pipe of AA

&  $Z_2, P_2, V_2, Q_2$  are the corresponding values at BB.

Let the liquid between the two sections AA & BB move to AA' & BB' through very small length  $dl_1$  &  $dl_2$

Let W is the weight of the liquid between AA & A<sub>1</sub>A<sub>1</sub> & BB & B<sub>1</sub>B<sub>1</sub> as the flow is continuous

$$\begin{aligned} W &= wa_1dl_1 = wa_2dl_2 \\ &= a_1dl_1 = \frac{W}{\omega} = a_2dl_2 \end{aligned}$$

$$\begin{aligned} \text{The work done by pressure of AA in moving the liquid A'A'} \\ &= \text{Force X distance} \\ &= P_1Q_1dl_1 \end{aligned}$$

Similarly

Work done by pressure at BB

$$= - P_2Q_2dl_2$$

Total work done by pressure

$$= P_1A_1dl_1 - P_2Q_2dl_2$$

$$= P_1A_1dl_1 - P_2Q_1dl_1$$

$$= a_1dl_1(P_1 - P_2)$$

$$= \frac{W}{\omega} (P_1 - P_2)$$

Loss of Potential energy

$$= w(Z_1 - Z_2)$$

Gain in Kinetic energy

$$= \frac{W}{2g} (V_2^2 - V_1^2)$$

Loss of potential energy + work done by pressure

$$= \text{Gain in kinetic energy}$$

$$\omega(Z_1 - Z_2) + \frac{W}{\omega} (P_1 - P_2) = \frac{W}{2g} (V_2^2 - V_1^2)$$

$$Z_1 - Z_2 + \frac{P_1}{\omega} - \frac{P_2}{\omega} = \frac{V_2^2}{2g} - \frac{V_1^2}{2g}$$

$$\frac{P_1}{\omega} + \frac{V_1^2}{2g} + Z_1 = \frac{P_2}{\omega} + \frac{V_2^2}{2g} + Z_2$$

**Limitations:**

1. the velocity of the liquid particle at the center of cross section is maximum. And the velocity gradually decreases towards the periphery of the pipe due to friction offered by the walls of the pipe line but in Bernoulli's equation it has been assumed that the velocity of liquid particle at any point across section is uniform.
2. Loss of energy due to pipe friction during flow of liquid, from one section to another are neglected in Bernoulli's equation.
3. Bernoulli's equation does not take into consideration loss of energy due to turbulent flow.
4. Bernoulli's equation does not take into consideration the loss of energy due to change of direction.

**Problem:- 5**

Water is flowing through a pipe of 5cm diameter under a pressure of 29.43 N/cm<sup>2</sup> (gauge) and with mean velocity of 2.0 m/s. Find the total head or total energy per unit weight of the water at a cross-section, which is 5m above the datum line.

**Solution.** Given :

Diameter of pipe	= 5 cm = 0.5 m	
Pressure,	$p = 29.43 \text{ N/cm}^2 = 29.43 \times 10^4 \text{ N/m}^2$	
Velocity,	$v = 2.0 \text{ m/s}$	
Datum head,	$z = 5 \text{ m}$	
Total head	= pressure head + kinetic head + datum head	
Pressure head	$= \frac{p}{\rho g} = \frac{29.43 \times 10^4}{1000 \times 9.81} = 30 \text{ m}$	$\left\{ \rho \text{ for water} = 1000 \frac{\text{kg}}{\text{m}^3} \right\}$
Kinetic head	$= \frac{v^2}{2g} = \frac{2 \times 2}{2 \times 9.81} = 0.204 \text{ m}$	
$\therefore$ Total head	$= \frac{p}{\rho g} + \frac{v^2}{2g} + z = 30 + 0.204 + 5 = 35.204 \text{ m. Ans.}$	

**Problem:- 6**

A pipe, through which water is flowing, is having diameters, 20cm and 10cm at the cross sections 1 and 2 respectively. The velocity of water at section 1 is given 4.0 m/s. Find the velocity head at sections 1 and 2 and also rate of discharge.

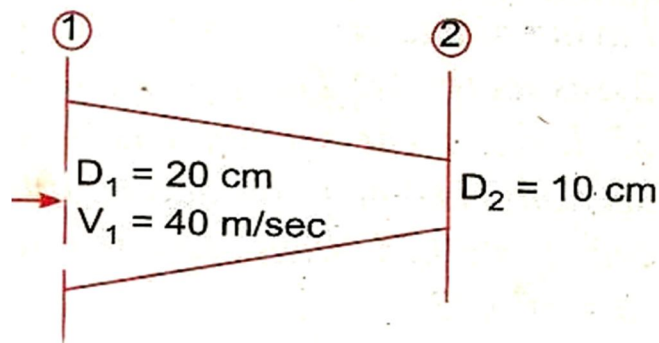



**Solution.** Given :

$$D_1 = 20 \text{ cm} = 0.2 \text{ m}$$

$$\therefore \text{Area, } A_1 = \frac{\pi}{4} D_1^2 = \frac{\pi}{4} (.2)^2 = 0.0314 \text{ m}^2$$

$$V_1 = 4.0 \text{ m/s}$$

$$D_2 = 0.1 \text{ m}$$

$$\therefore A_2 = \frac{\pi}{4} (.1)^2 = .00785 \text{ m}^2$$

(i) Velocity head at section 1

$$= \frac{V_1^2}{2g} = \frac{4.0 \times 4.0}{2 \times 9.81} = \mathbf{0.815 \text{ m. Ans.}}$$

(ii) Velocity head at section 2 =  $V_2^2/2g$

To find  $V_2$ , apply continuity equation at 1 and 2

$$\therefore A_1 V_1 = A_2 V_2 \quad \text{or} \quad V_2 = \frac{A_1 V_1}{A_2} = \frac{.0314}{.00785} \times 4.0 = 16.0 \text{ m/s}$$

$$\therefore \text{Velocity head at section 2} = \frac{V_2^2}{2g} = \frac{16.0 \times 16.0}{2 \times 9.81} = \mathbf{83.047 \text{ m. Ans.}}$$

(iii) Rate of discharge

$$= A_1 V_1 \quad \text{or} \quad A_2 V_2 \\ = 0.0314 \times 4.0 = 0.1256 \text{ m}^3/\text{s}$$

**Application of Bernoulli's equation:**

Bernoulli's equation is applied in all problems of incompressible fluid flow where energy consideration are involved. It is also applied to following measuring devices

1. Venturimeter
2. Orifice meter
3. Pitot tube

**Venturimeter:**

A venturimeter is a device used for measuring the rate of a flow of a fluid flowing through a pipe it consists of three parts.

- I. Short converging part
- II. Throat
- III. Diverging part

**Expression for rate of flow through venturimeter:**

Consider a venturimeter is fitted in a horizontal pipe through which a fluid flowing

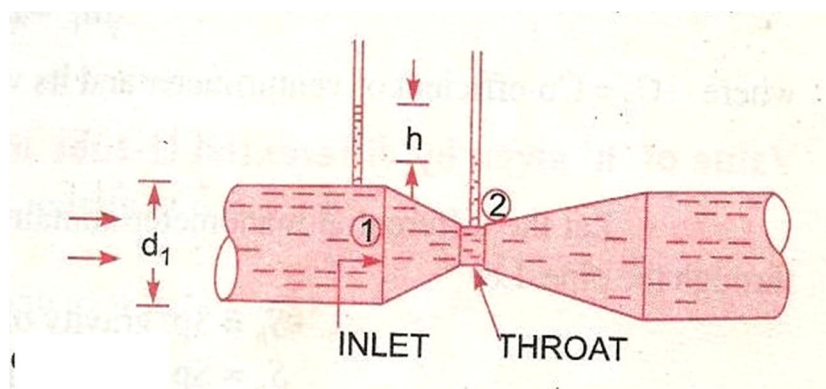

Let  $d_1$  = diameter at inlet or at section (i)-(ii)

$P_1$  = pressure at section (1)-(1)

$V_1$  = velocity of fluid at section (1) – (1)

$$A_1 = \text{area at section (1) – (1)} = \frac{\pi}{4} d_1^2$$

$D_2, p_2, v_2, a_2$  are corresponding values at section 2 applying Bernoulli's equation at sections 1 and 2 we get

$$\frac{p_1}{\rho g} + \frac{v_1^2}{2g} + z_1 = \frac{p_2}{\rho g} + \frac{v_2^2}{2g} + z_2$$

As pipe is horizontal, hence  $z_1 = z_2$

$$\therefore \frac{p_1}{\rho g} + \frac{v_1^2}{2g} = \frac{p_2}{\rho g} + \frac{v_2^2}{2g} \quad \text{or} \quad \frac{p_1 - p_2}{\rho g} = \frac{v_2^2}{2g} - \frac{v_1^2}{2g}$$

But  $\frac{p_1 - p_2}{\rho g}$  is the difference of pressure heads at sections 1 and 2

and it is equal to h

$$\text{So, } h = \frac{v_2^2}{2g} - \frac{v_1^2}{2g}$$

Now applying continuity equation at sections 1 & 2  $a_1 v_1 = a_2 v_2$

$$\text{Or } v_1 = \frac{a_2 v_2}{a_1}$$

Substituting this value

$$h = \frac{v_2^2}{2g} - \frac{\left(\frac{a_2 v_2}{a_1}\right)^2}{2g} = \frac{v_2^2}{2g} \left[1 - \frac{a_2^2}{a_1^2}\right] = \frac{v_2^2}{2g} \left[\frac{a_1^2 - a_2^2}{a_1^2}\right]$$

$$v_2^2 = 2gh \frac{a_1^2}{a_1^2 - a_2^2}$$

$$v_2 = \sqrt{2gh \frac{a_1^2}{a_1^2 - a_2^2}} = \frac{a_1}{\sqrt{a_1^2 - a_2^2}} \sqrt{2gh}$$

$$Q = a_2 v_2$$

$$= a_2 \frac{a_1}{\sqrt{a_1^2 - a_2^2}} \times \sqrt{2gh} = \frac{a_1 a_2}{\sqrt{a_1^2 - a_2^2}} \times \sqrt{2gh}$$

Where Q = Theoretical discharge

Actual discharge will be less than theoretical discharge

$$Q_{act} = C_d \times \frac{a_1 a_2}{\sqrt{a_1^2 - a_2^2}} \times \sqrt{2gh}$$

Where  $C_d$  = co-efficient of venturimetre and value is less than 1

### Value of 'h' given by differential U-tube manometer:

#### Case-i:

Let the differential manometer contains a liquid which is heavier than the liquid flowing through the pipe

Let  $S_h$  = Sp. Gravity of the heavier liquid

$S_0$  = Sp. Gravity of the liquid flowing through pipe

x = difference of the heavier liquid column in U-tube

$$P_A - P_B = gx(\rho_g - \rho_0)$$

$$\frac{P_A - P_B}{\rho_0 g} = x \left( \frac{\rho_g}{\rho_0} - 1 \right)$$

$$h = x \left[ \frac{S_h}{S_0} - 1 \right]$$

**Case-ii**

If the differential manometer contains a liquid lighter than the liquid flowing through the pipe

Where  $S_l$  = Specific gravity of lighter liquid in U-tube manometre

$S_o$  = Specific gravity of fluid flowing through in U-tube manometre

$x$  = Difference of lighter liquid columns in U- tube

The value of  $h$  is given by

$$h = x \left[ 1 - \frac{S_l}{S_o} \right]$$

**Case-iii:**

Inclined venturimeter with differential U-tube manometre

Let the differential manometer contains heavier liquid

Then  $h$  is given as

$$h = \left[ \frac{P_1}{\rho g} + z_1 \right] - \left[ \frac{P_2}{\rho g} + z_2 \right]$$

$$= x \left[ \frac{S_h}{S_o} - 1 \right]$$

**Case-iv:**

Similarly for inclined venturimeter in which differential manometer contains a liquid which is lighter than the liquid flowing through the pipe.

Then

$$h = \left[ \frac{P_1}{\rho g} + z_1 \right] - \left[ \frac{P_2}{\rho g} + z_2 \right]$$

$$h = x \left[ 1 - \frac{S_l}{S_o} \right]$$

**Limitations:**

- Bernoulli's equation has been derived under the assumption that no external force except the gravity force is acting on the liquid. But in actual practice some external forces always act on the liquid when effect the flow of liquid
- If the liquid is flowing in a curved path the energy due to centrifugal force should also be taken into account.

**Pitot-tube:**

It is a device used for measuring the velocity of flow at any point in a pipe or a channel.

It is based on the principle that if the velocity flow at a point becomes zero, the pressure there is increased due to conversion of the kinetic energy into pressure energy.

The pitot-tube consists of a glass tube, bent at right angles

Consider two points 1 and 2 at the same level. Such a way that 2 is at the inlet of pitot tube and one is far away from the tube

Let  $P_1$  = pressure at point 1

$V_1$  = velocity of fluid at point 1

$P_2$  = pressure at 2

$V_2$  = velocity of fluid at point 2

$H$  = Depth of tube in the liquid

$h$  = Rise of the liquid in the tube above the free surface

Applying Bernoulli's theorem

$$\frac{P_1}{\rho g} + \frac{V_1^2}{2g} + Z_1 = \frac{P_2}{\rho g} + \frac{V_2^2}{2g} + Z_2$$

$$\frac{P_1}{\rho g} = H \quad \frac{P_2}{\rho g} = (h + H)$$

$$H + \frac{V_1^2}{2g} = h + H$$

$$V_1 = \sqrt{2gh}$$

Actual velocity,  $V_{act} = C_v \sqrt{2gh}$

$C_v$  = co-efficient of Pitot-tube

### Different Arrangement of Pitot tubes

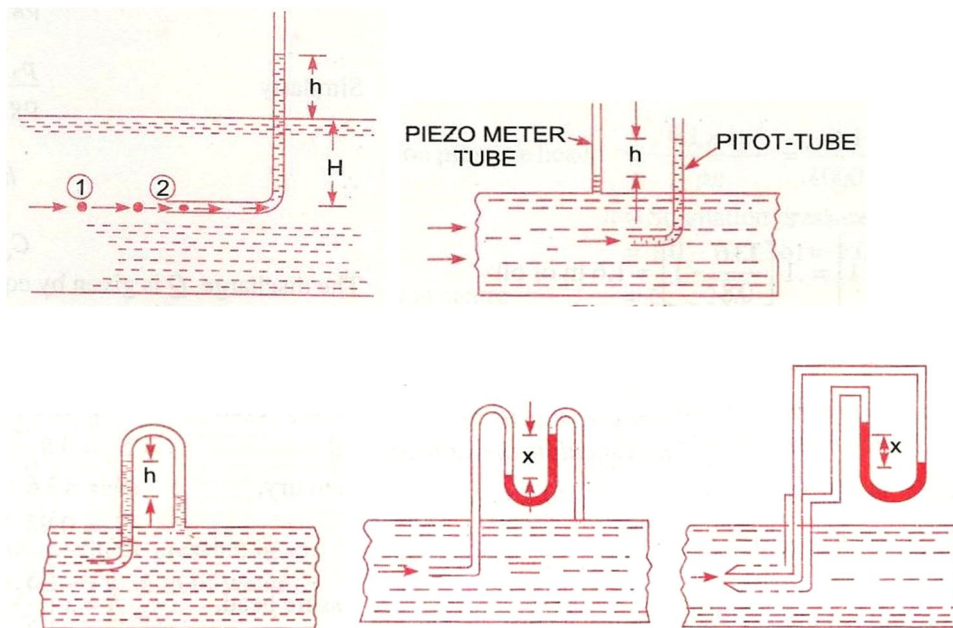

**Numerical Problems:****Problem:- 7**

Water is flowing through a pipe of 5cm diameter under a pressure of 29.43 N/cm<sup>2</sup> (gauge) and with mean velocity of 2.0 m/s. Find the total head or total energy per unit weight of the water at a cross-section, which is 5m above the datum line.

**Solution.** Given :

Diameter of pipe	= 5 cm = 0.5 m	
Pressure,	$p = 29.43 \text{ N/cm}^2 = 29.43 \times 10^4 \text{ N/m}^2$	
Velocity,	$v = 2.0 \text{ m/s}$	
Datum head,	$z = 5 \text{ m}$	
Total head	= pressure head + kinetic head + datum head	
Pressure head	$= \frac{p}{\rho g} = \frac{29.43 \times 10^4}{1000 \times 9.81} = 30 \text{ m}$	$\left\{ \rho \text{ for water} = 1000 \frac{\text{kg}}{\text{m}^3} \right\}$
Kinetic head	$= \frac{v^2}{2g} = \frac{2 \times 2}{2 \times 9.81} = 0.204 \text{ m}$	
$\therefore$ Total head	$= \frac{p}{\rho g} + \frac{v^2}{2g} + z = 30 + 0.204 + 5 = 35.204 \text{ m. Ans.}$	

**Problem:- 8**

The water is flowing through a pipe having diameters 20 cm and 10 cm at sections 1 and 2 respectively. The rate of flow through pipe is 35lit/s. The section 1 is 6m above datum and section 2 is 4m above datum. If the pressure at section 1 is 39.24 N/cm<sup>2</sup>. Find the intensity of pressure at section 2

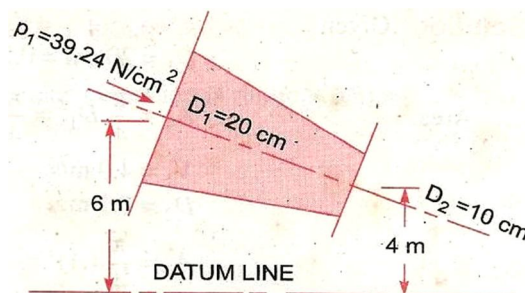



**Solution:**

Given

At section 1,

$$D_1 = 20 \text{ cm} = 0.2 \text{ m}$$

$$A_1 = \frac{\pi}{4} (.2)^2 = .0314 \text{ m}^2$$

$$p_1 = 39.24 \text{ N/cm}^2 \\ = 39.24 \times 10^4 \text{ N/m}^2$$

$$z_1 = 6.0 \text{ m}$$

At section 2,

$$D_2 = 0.10 \text{ m}$$

$$A_2 = \frac{\pi}{4} (0.1)^2 = .00785 \text{ m}^2$$

$$z_2 = 4 \text{ m}$$

$$p_2 = ?$$

Rate of flow,

$$Q = 35 \text{ lit/s} = \frac{35}{1000} = .035 \text{ m}^3/\text{s}$$

Now

$$Q = A_1 V_1 = A_2 V_2$$

 $\therefore$ 

$$V_1 = \frac{Q}{A_1} = \frac{.035}{.0314} = 1.114 \text{ m/s}$$

and

$$V_2 = \frac{Q}{A_2} = \frac{.035}{.00785} = 4.456 \text{ m/s}$$

Applying Bernoulli's equation at sections 1 and 2, we get

$$\frac{p_1}{\rho g} + \frac{V_1^2}{2g} + z_1 = \frac{p_2}{\rho g} + \frac{V_2^2}{2g} + z_2$$

$$\text{or } \frac{39.24 \times 10^4}{1000 \times 9.81} + \frac{(1.114)^2}{2 \times 9.81} + 6.0 = \frac{p_2}{1000 \times 9.81} + \frac{(4.456)^2}{2 \times 9.81} + 4.0$$

$$\text{or } 40 + 0.063 + 6.0 = \frac{p_2}{9810} + 1.012 + 4.0$$

$$\text{or } 46.063 = \frac{p_2}{9810} + 5.012$$

$$\therefore \frac{p_2}{9810} = 46.063 - 5.012 = 41.051$$

$$\therefore p_2 = 41.051 \times 9810 \text{ N/m}^2 \\ = \frac{41.051 \times 9810}{10^4} \text{ N/cm}^2 = 40.27 \text{ N/cm}^2.$$

**Problem:- 9**

Water is flowing through a pipe having diameter 300mm and 200 mm at the bottom and upper end respectively. The intensity of pressure at the bottom end is  $9.81\text{N/m}^2$ . Determine the difference in datum head if the rate of flow through pipe is 40 lit/s

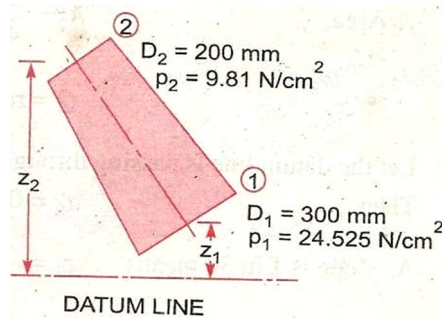

**Solution.** Given :

**Section 1,**  $D_1 = 300 \text{ mm} = 0.3 \text{ m}$   
 $p_1 = 24.525 \text{ N/cm}^2 = 24.525 \times 10^4 \text{ N/m}^2$

**Section 2,**  $D_2 = 200 \text{ mm} = 0.2 \text{ m}$   
 $p_2 = 9.81 \text{ N/cm}^2 = 9.81 \times 10^4 \text{ N/m}^2$

Rate of flow = 40 lit/s

or  $Q = \frac{40}{1000} = 0.04 \text{ m}^3/\text{s}$

Now  $A_1 V_1 = A_2 V_2 = \text{rate of flow} = 0.04$

$$\therefore V_1 = \frac{.04}{A_1} = \frac{.04}{\frac{\pi}{4} D_1^2} = \frac{0.04}{\frac{\pi}{4} (0.3)^2} = 0.5658 \text{ m/s}$$

$$\approx 0.566 \text{ m/s}$$

$$V_2 = \frac{.04}{A_2} = \frac{.04}{\frac{\pi}{4} (D_2)^2} = \frac{0.04}{\frac{\pi}{4} (0.2)^2} = 1.274 \text{ m/s}$$

Applying Bernoulli's equation at (1) and (2), we get

$$\frac{p_1}{\rho g} + \frac{V_1^2}{2g} + z_1 = \frac{p_2}{\rho g} + \frac{V_2^2}{2g} + z_2$$

$$\text{or } \frac{24.525 \times 10^4}{1000 \times 9.81} + \frac{.566 \times .566}{2 \times 9.81} + z_1 = \frac{9.81 \times 10^4}{1000 \times 9.81} + \frac{(1.274)^2}{2 \times 9.81} + z_2$$

$$\text{or } 25 + .32 + z_1 = 10 + 1.623 + z_2$$

$$\text{or } 25.32 + z_1 = 11.623 + z_2$$

$$\therefore z_2 - z_1 = 25.32 - 11.623 = 13.697 = 13.70 \text{ m}$$

$$\therefore \text{Difference in datum head} = z_2 - z_1 = \mathbf{13.70 \text{ m. Ans.}}$$

**Problem:- 10**

A horizontal venturimeter with inlet and throat diameters 10cm and 15 cm respectively is used to measure the flow of water. The reading of differential manometer connected to the inlet and throat is 20cm of mercury. Determine the rate of flow. Take  $C_d = 0.98$

**Solution.** Given :

Dia. at inlet,  $d_1 = 30 \text{ cm}$

$\therefore$  Area at inlet,  $a_1 = \frac{\pi}{4} d_1^2 = \frac{\pi}{4} (30)^2 = 706.85 \text{ cm}^2$

Dia. at throat,  $d_2 = 15 \text{ cm}$

$\therefore$   $a_2 = \frac{\pi}{4} \times 15^2 = 176.7 \text{ cm}^2$

$C_d = 0.98$

Reading of differential manometer =  $x = 20 \text{ cm}$  of mercury.

$\therefore$  Difference of pressure head is given by (6.9)

or 
$$h = x \left[ \frac{S_h}{S_o} - 1 \right]$$

where  $S_h = \text{Sp. gravity of mercury} = 13.6$ ,  $S_o = \text{Sp. gravity of water} = 1$

$$= 20 \left[ \frac{13.6}{1} - 1 \right] = 20 \times 12.6 \text{ cm} = 252.0 \text{ cm of water.}$$

The discharge through venturimeter is given by eqn. (6.8)

$$Q = C_d \frac{a_1 a_2}{\sqrt{a_1^2 - a_2^2}} \times \sqrt{2gh}$$

$$= 0.98 \times \frac{706.85 \times 176.7}{\sqrt{(706.85)^2 - (176.7)^2}} \times \sqrt{2 \times 9.81 \times 252}$$

$$= \frac{86067593.36}{\sqrt{499636.9 - 31222.9}} = \frac{86067593.36}{684.4}$$

$$= 125756 \text{ cm}^3/\text{s} = \frac{125756}{1000} \text{ lit/s} = \mathbf{125.756 \text{ lit/s.}}$$

**Problem:- 11**

An oil of Sp.gr. 0.8 is flowing through a horizontal venturimeter having inlet diameter 20cm and throat diameter 10 cm. The oil mercury differential manometer shows a reading of 25cm. Calculate the discharge of oil through the horizontal venturimeter. Take  $C_d = 0.98$

**Solution.** Given :

Sp. gr. of oil,  $S_o = 0.8$

Sp. gr. of mercury,  $S_h = 13.6$

Reading of differential manometer,  $x = 25$  cm

$$\begin{aligned} \therefore \text{Difference of pressure head, } h &= x \left[ \frac{S_h}{S_o} - 1 \right] \\ &= 25 \left[ \frac{13.6}{0.8} - 1 \right] \text{ cm of oil} = 25 [17 - 1] = 400 \text{ cm of oil.} \end{aligned}$$

Dia. at inlet,  $d_1 = 20$  cm

$$\therefore a_1 = \frac{\pi}{4} d_1^2 = \frac{\pi}{4} \times 20^2 = 314.16 \text{ cm}^2$$

$d_2 = 10$  cm

$$\therefore a_2 = \frac{\pi}{4} \times 10^2 = 78.54 \text{ cm}^2$$

$C_d = 0.98$

$\therefore$  The discharge  $Q$  is given by equation (6.8)

or

$$\begin{aligned} Q &= C_d \frac{a_1 a_2}{\sqrt{a_1^2 - a_2^2}} \times \sqrt{2gh} \\ &= 0.98 \times \frac{314.16 \times 78.54}{\sqrt{(314.16)^2 - (78.54)^2}} \times \sqrt{2 \times 981 \times 400} \\ &= \frac{21421375.68}{\sqrt{98696 - 6168}} = \frac{21421375.68}{304} \text{ cm}^3/\text{s} \\ &= 70465 \text{ cm}^3/\text{s} = \mathbf{70.465 \text{ litres/s. Ans.}} \end{aligned}$$

**Problem:- 12**

A horizontal venturimeter with inlet and throat diameters 20cm and 10 cm respectively is used to measure the flow of oil of Sp. gr. 0.8. The discharge of oil through venturimeter is 60lit/s . Find the reading of oil-mercury differential manometer. Take  $C_d = 0.98$

**Solution.** Given :

$$d_1 = 20 \text{ cm}$$

$$\therefore a_1 = \frac{\pi}{4} 20^2 = 314.16 \text{ cm}^2$$

$$d_2 = 10 \text{ cm}$$

$$\therefore a_2 = \frac{\pi}{4} \times 10^2 = 78.54 \text{ cm}^2$$

$$C_d = 0.98$$

$$Q = 60 \text{ litres/s} = 60 \times 1000 \text{ cm}^3/\text{s}$$

Using the equation (6.8),  $Q = C_d \frac{a_1 a_2}{\sqrt{a_1^2 - a_2^2}} \times \sqrt{2gh}$

or  $60 \times 1000 = 9.81 \times \frac{314.16 \times 78.54}{\sqrt{(314.16)^2 - (78.54)^2}} \times \sqrt{2 \times 981 \times h}$

$$= \frac{1071068.78 \sqrt{h}}{304}$$

or  $\sqrt{h} = \frac{304 \times 60000}{1071068.78} = 17.029$

$\therefore h = (17.029)^2 = 289.98 \text{ cm of oil}$

But  $h = x \left[ \frac{S_h}{S_o} - 1 \right]$

where  $S_h = \text{Sp. gr. of mercury} = 13.6$   
 $S_o = \text{Sp. gr. of oil} = 0.8$   
 $x = \text{Reading of manometer}$

$\therefore 289.98 = x \left[ \frac{13.6}{0.8} - 1 \right] = 16x$

$\therefore x = \frac{289.98}{16} = 18.12 \text{ cm.}$

$\therefore \text{Reading of oil-mercury differential manometer} = \mathbf{18.12 \text{ cm.}}$

**Problem:-13**

A static pitot-tube placed in the centre of a 300 mm pipe line has one orifice pointing upstream and is perpendicular to it. The mean velocity in the pipe is 0.80 of the central velocity. Find the discharge through the pipe if the pressure difference between the two orifices is 60mm of water. Take  $C_v = 0.98$

**Solution.** Given :

Dia. of pipe,  $d = 300 \text{ mm} = 0.30 \text{ m}$   
 Diff. of pressure head,  $h = 60 \text{ mm of water} = .06 \text{ m of water}$   
 $C_v = 0.98$

Mean velocity,  $\bar{V} = 0.80 \times \text{Central velocity}$

Central velocity is given by equation (6.14)

$$= C_v \sqrt{2gh} = 0.98 \times \sqrt{2 \times 9.81 \times .06} = 1.063 \text{ m/s}$$

$\therefore \bar{V} = 0.80 \times 1.063 = 0.8504 \text{ m/s}$

Discharge,  $Q = \text{Area of pipe} \times \bar{V}$

$$= \frac{\pi}{4} d^2 \times \bar{V} = \frac{\pi}{4} (.30)^2 \times 0.8504 = \mathbf{0.06 \text{ m}^3/\text{s. Ans.}}$$

**Orifice:**

Orifice is a small opening of any Cross-section (such as triangular, rectangular etc) on the side or at the bottom of a tank, through which a fluid is flowing. Orifices are used for measuring the rate of flow of fluid.

Applying Bernoulli's theorem at 1 and 2

$$\frac{P_1}{\rho g} + \frac{V_1^2}{2g} + Z_1 = \frac{P_2}{\rho g} + \frac{V_2^2}{2g} + Z_2$$

$$H + 0 = 0 + \frac{V_2^2}{2g}$$

$$V_2 = \sqrt{2gh}$$

**Orifice Co-efficients:**

The Orifice co-efficients are

- **Co-efficient of velocity  $C_v$**
- **Co-efficient of contraction  $C_c$**
- **Co-efficient of discharge  $C_d$**

**Co-efficient of velocity  $C_v$ :**

It is defined as the ratio between the actual velocity of a jet of liquid at vena-contra and the theoretical velocity of jet. It is denoted by  $C_v$  and Mathematically  $C_v$  is given as

$$C_v = \frac{\text{Actual velocity of jet at vena-contra}}{\text{Theoretical velocity}}$$

$$= \frac{V}{\sqrt{2gh}}$$

Where  $V$  = actual velocity

$$\sqrt{2gh} = \text{theoretical velocity}$$

The value of  $C_v$  varies from 0.95 to 0.99 for different orifices depending on the shape, size of the orifice.

### **Co-efficient of contraction:**

It is defined as the ratio of the area of the jet at vena-contra to the area of the orifice.

It is denoted by  $C_c$

$a$  = area of orifice

$a_c$  = area of jet at vena-contra

$$C_c = \frac{\text{area of jet at vena-contra}}{\text{area of orifice}}$$

$$= \frac{a_c}{a}$$

The value of  $C_c$  varies from 0.61 to 0.69 depending on shape and size of the orifice.

### **Co-efficient of Discharge:**

It is the ratio of the actual discharge from an orifice to the theoretical discharge from the orifice. It is denoted by  $C_d$

If  $Q$  is the actual discharge and  $Q_{th}$  is the theoretical discharge then

$$C_d = \frac{Q_{act}}{Q_{th}}$$

$$= \frac{\text{Actual velocity} \times \text{Actual area}}{\text{Theoretical velocity} \times \text{Theoretical area}}$$

$$= C_c \times C_v$$

The value of  $C_d$  varies from 0.61 to 0.65

For general purpose  $C_d$  is 0.62



### **Classification**

Orifices are classified on the basis of their size, shape and nature of discharge

#### **According to size**

- Small orifice (If the head of liquid above the centre of orifice is more than 5 times the depth of orifice)
- Large orifice (If head is less than 5 times the depth of orifice)

#### **According to shape**

1. Circular
2. Triangular
3. Rectangular
4. Square

#### **According to the shape of upstream edge:**

- Sharp edged orifice
- Bell mouthed orifice

#### **According to nature of discharge:**

- Free discharge orifices
- Drowned or submerged orifices
  - Partially submerged orifices
  - Fully submerged orifices

#### **Orifice Meter or Orifice Plate:**

It is a device used for measuring the rate of flow of a fluid through a pipe. It is a cheaper device as compared to venturimeter. It also works on the same principle as that of venturimeter. It consists of a flat circular plate which has a circular sharp edge hole called orifice, which is concentric with the pipe. The orifice diameter is kept generally 0.5 times the diameter of the pipe, though it may vary 0.4 to 0.8 times the pipe diameter.

A differential manometer is connected at section 1 which is at a distance of about 1.5 to 2.0 times the pipe diameter of upstream of the orifice plate and at section 2, which is at a distance about half the diameter of the orifice on the downstream side from the orifice plate

Let  $p_1$  = pressure at section (1),  
 $v_1$  = velocity at section (1),  
 $a_1$  = area of pipe at section (1), and

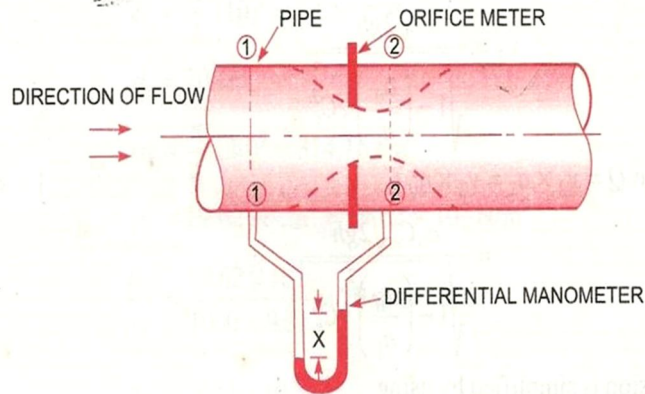

Fig. 6.12. Orifice meter.

$p_2, v_2, a_2$  are corresponding values at section (2). Applying Bernoulli's equation at sections (1) and (2), we get

$$\frac{p_1}{\rho g} + \frac{v_1^2}{2g} + z_1 = \frac{p_2}{\rho g} + \frac{v_2^2}{2g} + z_2$$

or 
$$\left( \frac{p_1}{\rho g} + z_1 \right) - \left( \frac{p_2}{\rho g} + z_2 \right) = \frac{v_2^2}{2g} - \frac{v_1^2}{2g}$$

But 
$$\left( \frac{p_1}{\rho g} + z_1 \right) - \left( \frac{p_2}{\rho g} + z_2 \right) = h = \text{Differential head}$$

$$\therefore h = \frac{v_2^2}{2g} - \frac{v_1^2}{2g} \quad \text{or} \quad 2gh = v_2^2 - v_1^2$$

or 
$$v_2 = \sqrt{2gh + v_1^2} \quad \dots(i)$$

Now section (2) is at the vena contracta and  $a_2$  represents the area at the vena contracta. If  $a_0$  is the area of orifice then, we have

$$C_c = \frac{a_2}{a_0}$$

where  $C_c$  = Co-efficient of contraction

$$\therefore a_2 = a_0 \times C_c \quad \dots(ii)$$

By continuity equation, we have

$$a_1 v_1 = a_2 v_2 \quad \text{or} \quad v_1 = \frac{a_2}{a_1} v_2 = \frac{a_0 C_c}{a_1} v_2 \quad \dots(iii)$$

Substituting the value of  $v_1$  in equation (i), we get

$$v_2 = \sqrt{2gh + \frac{a_0^2 C_c^2 v_2^2}{a_1^2}}$$

or 
$$v_2^2 = 2gh + \left(\frac{a_0}{a_1}\right)^2 C_c^2 v_2^2 \text{ or } v_2^2 = \left[1 - \left(\frac{a_0}{a_1}\right)^2 C_c^2\right] = 2hg$$

$$\therefore v_2 = \frac{\sqrt{2gh}}{\sqrt{1 - \left(\frac{a_0}{a_1}\right)^2 C_c^2}}$$

$$\therefore \text{The discharge } Q = v_2 \times a_2 = v_2 \times a_0 C_c$$

$$= \frac{a_0 C_c \sqrt{2gh}}{\sqrt{1 - \left(\frac{a_0}{a_1}\right)^2 C_c^2}}$$

The above expression is simplified by using

$$C_d = C_c \frac{\sqrt{1 - \left(\frac{a_0}{a_1}\right)^2}}{\sqrt{1 - \left(\frac{a_0}{a_1}\right)^2 C_c^2}}$$

$$\therefore C_c = C_d \frac{\sqrt{1 - \left(\frac{a_0}{a_1}\right)^2 C_c^2}}{\sqrt{1 - \left(\frac{a_0}{a_1}\right)^2}}$$

Substituting this value of  $C_c$  in equation (iv), we get

$$Q = a_0 \times C_d \frac{\sqrt{1 - \left(\frac{a_0}{a_1}\right)^2 C_c^2}}{\sqrt{1 - \left(\frac{a_0}{a_1}\right)^2}} \times \frac{\sqrt{2gh}}{\sqrt{1 - \left(\frac{a_0}{a_1}\right)^2 C_c^2}}$$

$$= \frac{C_d a_0 \sqrt{2gh}}{\sqrt{1 - \left(\frac{a_0}{a_1}\right)^2}} = \frac{C_d a_0 a_1 \sqrt{2gh}}{\sqrt{a_1^2 - a_0^2}}$$

where  $C_d$  = Co-efficient of discharge for orifice meter.

The co-efficient of discharge for orifice meter is much smaller than that for a venturimeter.

# Chapter-5

## Flow through pipe

### Syllabus:

**5.1 Definition of pipe, laws of fluid friction**

**5.2 Head loss due to friction: Darcy's and Chezy's formula)**

**5.3 Hydraulic gradient and total gradient line**

### Pipe:

A pipe is a closed conduit , generally of circular cross-section used to carry watter or any other fluid.

When the pipe is running full, the flow is under pressure but if the pipe is not running full the flow is nit unnder pressure (culverts, sewer pipes)

**Loss of fluid friction:**

The frictional resistance of a pipe depends upon the roughness of the inside surface of the pipe more the roughness more is the resistance. This friction is known as fluid friction and the resistance is known as frictional resistance

**According Froude**

The frictional resistance varies with the square of the velocity.

The friction resistance varies with the natural of the surface.

Among various laws, the Darcy-weisbach formula & Chezy's formula.

**Loss of energy in pipes:**

When a fluid is flowing through a pipe, the fluid experiences some, resistance due to which some of energy is lost.

Energy losses:

major energy losses

due to friction

it is calculated by

a-darcy-weisbach formula  
pipe

b-chezy's formula

minor energy losses

due to

1-sudden expansion of pipe

2-sudden contraction of

3-bend in pipe

4-pipe fittings etc

5-an obstruction in pipe.

**Darcy- weisbach formula:**

The loss of head in pipes due to friction calculated from darcy-weisbach equation.

$$h_f = \frac{4FLV^2}{2gd}$$

$h_f$  = loss of head due to friction

$F$  = coefficient of friction (function of reylond's number)

$$= \frac{16}{R_e} \text{ for } R_e < 2000 \text{ (viscous flow)}$$

$$= \frac{0.079}{R_e^{\frac{1}{4}}} \text{ for } R_e \text{ varying from } 4000 \text{ to } 10^6$$

$L$  = length of the pipe

$V$  = mean velocity of flow

$D$  = diameter of the pipe.

### **Chezy's formula:**

$$h_f = \frac{f'}{\delta g} \times \frac{P}{A} \times L \times V^2$$

$h_f$  = loss of head due to friction.

$P$  = wetted perimeter of pipe

$A$  = C.S area of pipe

$L$  = length of pipe

$V$  = m mean velocity of flow.

$$M = \frac{A}{P} = \frac{\text{area of flow}}{\text{perimeter}}$$

= hydraulic mean depth or hydraulic radius

$$\Rightarrow M = \frac{A}{p} = \frac{\frac{\pi d^2}{4}}{\pi d} = \frac{d}{4}$$

$$\text{Substituting } \frac{P}{A} = \frac{1}{M}$$

$$h_f = \frac{f^1}{\rho g} \times \frac{1}{M} \times L \times V^2$$

$$v^2 = h_f \times \frac{\rho g}{f^1} \times M \times \frac{1}{L}$$

$$v = \sqrt{\frac{fg}{f^1} \times M \times \frac{h_f}{L}}$$

$$\sqrt{\frac{fg}{f^1}} = C \text{ where } C \text{ is constant known as chezy's constant}$$

$$\frac{h_f}{L} = i \text{ loss of head per unit length}$$

Substituting  $V = c\sqrt{Mi}$  value of  $M$  is always  $\frac{d}{4}$ .

### **Hydraulic gradient line:**

It is defined as the line which gives the sum of pressure head  $P/W$  & datum head ( $Z$ ) if a flowing fluid in a pipe with respect to the reference line or it is the line which is obtained by joining of the top of all vertical ordinates showing pressure head ( $P/W$ ) of a flowing fluid in a pipe from the centre of the pipe. It is briefly written as H.G.L .

### **Total energy line:**

It is defined as the line which gives the sum of pressure head, datum head & kinetic head of a flowing fluid in a pipe with respect to some reference line or it is the line which is obtained by joining the tops of all vertical ordinates showing the sum of pressure head & kinetic head from the centre of the pipe. It is also written as T.E.L

## CHAPTER -6

# Impact of jets

### Syllabus:

- 6.1 Impact of jet on fixed and moving vertical flat plates, derivation of work done on series of vanes and condition for maximum efficiency**
- 6.2 Impact of jet on moving curved vanes, illustration using velocity triangles, derivation of work done, efficiency (Simple Numericals)**

### Introduction:

Impact of jet means the force exerted by the jet on a plate which may be stationary or moving

The various cases of impact of jet are:

1. force exerted by the jet on a stationary plate when
  - 1) plate is vertical to the jet
  - 2) plate is inclined to the jet
  - 3) plate is curved
2. force exerted by the jet on a moving plate when-
  1. plate is vertical to jet
  2. plate is inclined to the jet
  3. plate is curved

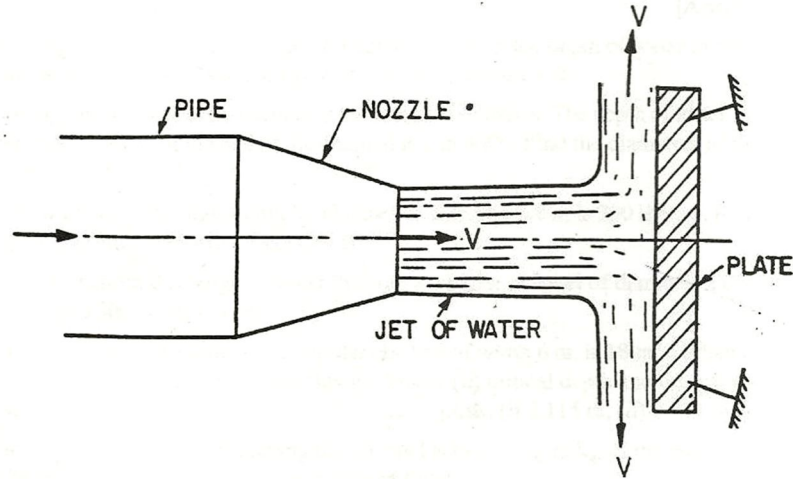

**Impact of jet flat surface :****Force exerted by jet on fixed vertical plate**

Consider a jet of water coming out from the nozzle strikes a flat vertical plate

Let  $v$  = velocity of the jet  
 $d$  = diameter of jet  
 $a$  = area of cross-section of the jet  
 $= \frac{\pi}{4} d^2$

As the plate is fixed, the jet after striking will get deflected through  $90^\circ$

Hence the component of the velocity of jet, in the direction of jet, after striking will be zero.

The force exerted by the jet on the plate in the direction of jet

$F_x$  = rate of change of momentum in the direction of force

$$= \frac{\text{initial momentum} - \text{final momentum}}{\text{Time}}$$

$$= \frac{\text{mass} \times \text{initial velocity} - \text{mass} \times \text{Final velocity}}{\text{Time}}$$

$$= \frac{\text{mass}}{\text{Time}} (\text{Initial velocity} - \text{Final velocity})$$

$$= \frac{\text{mass}}{\text{sec}} (\text{velocity of jet before striking} - \text{Final velocity of jet after$$

striking)

$$= \rho av [v - 0]$$

$$= \rho av^2$$

**NOTE:** In the above equation initial velocity minus final velocity is taken as because force exerted by the jet on the plate is is calculated if force exerted on the jet is to be calculated then final velocity is taken.

**NUMERICAL PROBLEMS****Problem-1**

Find the force exerted by a jet of water of diameter 75mm on a stationary flat plate when the jet strikes the plate normally with a velocity of 20m/s.

**Solution .**

Given:

$$\begin{aligned}\text{Diameter of jet} = d &= 75\text{mm} \\ &= 0.075\text{m}\end{aligned}$$

$$\text{Velocity of jet} = 20\text{m/s}$$

$$\begin{aligned}\text{Area} = a &= \frac{\pi}{4}d^2 \\ &= \frac{\pi}{4}(0.075)^2 \\ &= 0.004417 \text{ m}^2\end{aligned}$$

The force exerted by the jet of water on a stationary vertical plate is given by

$$\begin{aligned}F &= \rho av^2 \\ &= 1000 \times 0.004417 \times 20^2 \\ &= 1766.8 \text{ N}\end{aligned}$$

**Problem-2**

Water is flowing through a pipe at the end of which a nozzle is fitted . the diameter of the nozzle is 100mm and the head of water at the centre of nozzle 100m . find the force exerted by the jet of water on a fixed vertical plate . the co-efficient of velocity is given as 0.95

**SOLUTION:**

Given:

$$\text{Diameter of nozzle} = d = 100\text{mm} = 0.1\text{m}$$

$$\text{Head of water , } H = 100\text{m}$$

Co- efficient of velocity , $C_v = 0.95$

$$\text{Area of nozzle } a = \frac{\pi}{4} d^2 = \frac{\pi}{4} (0.1)^2 = 0.007854 \text{ m}^2$$

Theoretical velocity of jet of water is given as

$$V_{th} = \sqrt{2gH}$$

$$= \sqrt{2 \times 9.81 \times 100} = 44.294 \text{ M/S}$$

$$\text{But , } C_v = \frac{\text{actual velocity}}{\text{Theoretical velocity}}$$

$$\therefore \text{Actual velocity of jet of water (v) } = C_v \times v_{th}$$

$$V = 0.95 \times 44.294$$

$$= 42.08 \text{ M/S}$$

Force exerted on a field vertical plate is given by

$$F = \rho a v^2$$

$$= 1000 \times 0.07854 \times (42.08)^2 \quad (\rho = 1000 \text{ kg/m}^3)$$

$$= 13907.2 \text{ N} = 13.9 \text{ KN ans}$$

### Impact of jet on moving flat plate:

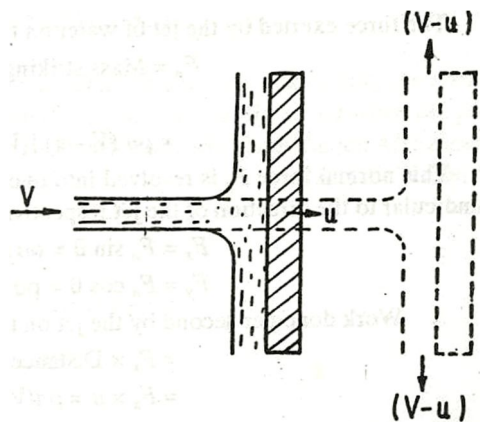

**Jet striking a flat vertical moving plate**

Consider a jet of water striking a flat vertical plate moving with a uniform velocity away from the jet ..

Let  $V$  = velocity of the jet (absolute )

$A$  = area of cross –section of the jet

$U$  = velocity of flat plate

In this case the jet strikes the plate with a relative velocity , which is equal to the absolute velocity of jet of water minus the velocity of the plate . Hence relative velocity of the jet with respect to plate = $v-u$

Mass of water striking the plate per sec

$$= \rho \times \text{area of jet} \times \text{velocity (relative)}$$

$$= \rho a \times [v - u]$$

Force exerted by the jet on the moving flat plate in the direction of motion of jet

$$F_x = \text{mass of water striking /sec} \times [\text{initial velocity} - \text{final velocity}]$$

$$= \rho a(v - u)[(v - u) - 0]$$

$$= \rho a(v - u)^2 \text{ (final velocity in the direction of jet is zero)}$$

In this case ,the work will be done by the jet on plate as the plate is moving

Work done per second by the jet on the plate

$$= \text{force} \times \frac{\text{distance in the direction of force}}{\text{time}}$$

$$= f_x \times u$$

$$= \rho a(v - u)^2 \times u$$

NOTE in case of stationary or fixed flat plate work done is zero.

### Jet striking a series of plates

In this case, a large number of flat plates are mounted on the rim of a wheel fixed distance apart. The jet strikes a plate and due to the force exerted by the jet on the plate, the wheel starts moving and the 2<sup>nd</sup> plate mounted on the wheel appears before the jet, which again exerts the force on the 2<sup>nd</sup> plate.

Thus each plate appears successively before the jet as the jet exerts force on each plate. The wheel starts moving at a constant speed

Let  $V$  = velocity of jet

$D$  = diameter of jet

$A$  = cross-sectional area of jet

$u$  = velocity of plate

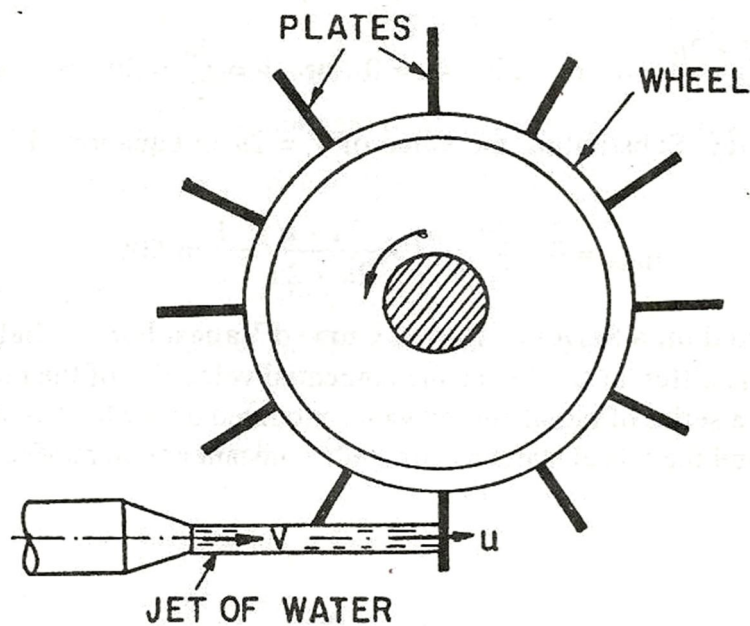

In this case the mass of water coming out from the nozzle per second is always in contact with the plates when all the plates are considered

Hence mass of water/sec =  $\rho av$

The jet strikes the plate with velocity =  $v - u$

The Force exerted by the jet in the direction of the motion of plate

$$\begin{aligned}
 F_x &= \frac{\text{mass}}{\text{Time}} (\text{Initial velocity} - \text{Final velocity}) \\
 &= \rho av[(v - u) - 0] \\
 &= \rho av(v - u)
 \end{aligned}$$

Work done per second by the jet on the surface of the plate per sec

$$\begin{aligned}
 &= F_x u \\
 &= \rho av(v - u) u
 \end{aligned}$$

Kinetic energy of the jet per second

$$\begin{aligned}
 &= \frac{1}{2} m v^2 \\
 &= \frac{1}{2} (\rho av) v^2 \\
 &= \frac{1}{2} \rho av^3
 \end{aligned}$$

Efficiency,  $= \frac{\text{Work done/sec}}{\text{Kinetic energy/sec}}$

$$\begin{aligned}
 &= \frac{\rho av(v - u) u}{\frac{1}{2} \rho av^3} \\
 &= \frac{2u(v - u)}{v^2}
 \end{aligned}$$

### Condition for maximum Efficiency

For a given jet velocity  $v$ , the efficiency will be maximum when

$$\begin{aligned}
 \frac{d}{du} &= 0 \\
 \Rightarrow \frac{d \left[ \frac{2u(v - u)}{v^2} \right]}{du} &= 0 \\
 \Rightarrow \frac{d \left[ \frac{2uv - u^2}{v^2} \right]}{du} &= 0
 \end{aligned}$$

$$\Rightarrow \frac{2v - 4u}{v^2} = 0$$

$$\Rightarrow 2v - 4u = 0$$

$$\Rightarrow u = \frac{v}{2}$$

### **Maximum Efficiency:**

Substituting the value of  $v = 2u$

We get maximum efficiency as

$$\begin{aligned} \eta_{max} &= \frac{2u(2u - u)}{(2u)^2} \\ &= \frac{1}{2} = 50\% \end{aligned}$$

### **IMPACT OF JET ON A MOVING CURVED PLATE WHEN JET STRIKES TANGENTISLY AT ONE OF THE TIPS:**

Consider a jet of water striking a moving curved vane tangentially at one of its tips. In this case as plate is moving, the velocity with which jet of water is equal to the relative velocity of the jet with respect to the plate

Let  $v_1$  = velocity of the jet at inlet

$u_1$  = velocity of the plate at inlet

$V_{r1}$  = Relative velocity of the jet & plate at inlet

$\alpha$  = guide blade angle

$\theta$  = vane angle made by relative velocity  $V_{r1}$  with the direction of motion of inlet

$V_{w1}$  &  $v_{f1}$  = Components of  $V_1$  in the direction of motion & perpendicular to the direction of motion of vane respectively

$V_{w1}$  = Whirl velocity at inlet

$V_{f1}$  = velocity at inlet

$V_2$  = velocity of the jet at outlet



$u_2$  = velocity of vane at out let

$V_{r2}$  = relative of the jet at out let

$\beta$  = Angle made by the velocity  $v_2$  with the direction of the motion of vane at outlet

$\phi$  = vane angle at outlet

$V_{w2}$  = velocity of whirl at oputlet

$V_{r2}$  = velocity of whirl at oputlet

The triangles ABD & EGH are called the velocity triangle at inlet & outlet

If the vane is smooth & having velocity in the direction of motion at inlet & outlet equal then we have

$$u_1 = u_2 = u$$

$$V_{r1} = v_{r2}$$

Now

Mass of water striking vane per sec =

Where  $a$  = area of jet

$V_{r1}$  = relative velocity at inlet

Force exerted by the jet in the direction of motion

$$F_x = \frac{\text{mass}}{\text{Time}} (\text{Initial velocity} - \text{Final velocity})$$

But initial velocity with which jet strikes thge vane =  $v_{r1}$

The component of this velocity inthe direction of motion

$$= v_{r1} \cos \theta$$

$$= (V_{w1} - u_1)$$

Similarly the component of relative velocity  $v_{r2}$  at outlet in the direction of motion =  $- v_{r2} \cos \phi$

$$= - [u_2 + v_{w2}]$$

(- ve sign is taken as the component of  $v_{r2}$  is in opposite direction)

Substituting these values in the above equation

$$\begin{aligned} F_x &= \rho a V r_1 [(v_{w1} - u_1) - \{ - (u_2 + v_{w2}) \}] \\ &= \rho a V r_1 [v_{w1} - u_1 + u_2 + v_{w2}] \\ &= a v r_1 (v_{w1} + v_{w2}) \end{aligned}$$

This equation is true only when  $\beta$  is acute when

$$\beta = 90^\circ$$

$$v_{w2} = 0$$

$$F_x = a v r_1 (v_{w1})$$

When  $\beta > 90^\circ$  (obtuse)

$$F_x = a v r_1 (v_{w1} - v_{w2})$$

In equation  $F_x$  is written as

$$F_x = a v r_1 (v_{w1} \pm v_{w2})$$

Work done/ sec on the vane by the jet

$$= F_x \times u$$

$$= \rho a v r_1 (v_{w1} \pm v_{w2}) \times u$$

Work done/sec/ unit weight of fluid striking/sec

$$= \frac{\rho a v r_1 [v_{w1} \pm v_{w2}] \times u}{\rho a v r_1 \times g}$$

$$= \frac{[v_{w1} \pm v_{w2}] \times u}{g}$$

Work done/sec/unit mass of water striking/ sec

$$\begin{aligned}
 &= \frac{\rho a v_{r1} [v_{w1} \pm v_{w2}] \times u}{\rho a v_{r1}} \\
 &= [v_{w1} \pm v_{w2}] \times u
 \end{aligned}$$

**Efficiency of jet:**

$$= \frac{\frac{\text{work done}}{\text{sec}} \text{ on the vane}}{\text{Initial Kinetic energy/ sec of the jet}}$$

$$= \frac{\rho a v_{r1} [v_{w1} \pm v_{w2}] \times u}{\frac{1}{2} m v^2}$$

$$= \frac{\rho a v_{r1} [v_{w1} \pm v_{w2}] \times u}{\frac{1}{2} \rho a v_1 \times v^2}$$

## Chapter - 7

### Hydraulic turbines

#### Syllabus:

**7.1 Layout and features of hydroelectric power plant**  
**7.2 Definition and classification of hydraulic turbines**  
**7.3 Construction and working principle of Impulse turbine (Pelton wheel) Velocity triangle of a single bucket, work done and efficiency in Pelton wheel (Numerical Problems)**  
**7.4 Construction and working principle of Reaction turbine (Francis turbine) Velocity triangle, work done and efficiency (Numerical Problems) Construction and working principle of Kaplan turbine**

#### Introduction:

Hydraulic machines are defined as those machines which convert either hydraulic energy into mechanical energy (whgich is further converted to electrical energy ) or mechanical energy into hydraulic energy.

Hydraulic machines are of two types

Turbines

Pumps

**Turbines:**

Turbines are defined as the hydraulic machines which convert hydraulic energy into mechanical energy. This mechanical energy is used in running an electric generator which is directly coupled to the shaft of the turbine. Thus mechanical energy is converted into electrical energy. The electrical power which is obtained from the hydraulic energy is known as Hydro-electric power.

**Classification of Hydraulic turbine**

Hydraulic Turbines are classified

**1. According to the type of energy at inlet**

- a. Impulse turbine – The energy available at inlet is only kinetic energy
- b. Reaction turbine – The water possesses kinetic energy as well as pressure energy at the inlet of the turbine.

**2. According to the direction of flow through runner**

- a. Tangential Flow Turbine – Water flows along the tangent of the runner
- b. Radial flow turbine – Water flows in the radial direction through the runner
- c. Axial flow turbine – Water flows through the runner along the direction parallel to the axis of rotation of the runner
- d. Mixed flow turbine – Water flows through the runner in the radial direction but leaves in the direction parallel to axis of rotation of runner.

**3. According to the head at the inlet of turbine**

- a. High head turbine
- b. Medium head turbine
- c. Low head turbine

**4. According to the specified speed of turbine**

- a. Low specific speed turbine
- b. Medium specific speed turbine
- c. High specific speed turbine

### Definitions of heads & Efficiencies of a turbine

#### 1. Gross Head

The difference between the head race level & tail race level when no water is flowing is known as gross head ( $H_g$ )

#### 2. Net Head

It is also called effective head & is defined as the head available at the inlet of the turbine. When water is flowing, a loss of head due to friction between the water & penstocks occurs.

So net head =  $H_g - h_f$

$H_g$  = gross head

$h_f$  = head loss due to friction

$$= \frac{4fLv^2}{2Dg}$$

Where  $v$  = velocity of flow in penstock

$L$  = Length of penstock

$D$  = Diameter of penstock

#### 3. Efficiencies of a turbine

The important efficiencies of a turbine are

- a. **Hydraulic efficiency**
- b. **Mechanical efficiency**
- c. **Volumetric efficiency**
- d. **Overall Efficiency**

##### (a) Hydraulic efficiency

$$h = \frac{\text{Power delivered to runner}}{\text{Power supplied at inlet}}$$

W.P. = Water Power

$$= \frac{W \times H}{1000} \text{ kW}$$

$W$  = weight of water striking the vanes of the turbine per second

$$= \rho g \phi$$

$$W.P. = \frac{\rho g \phi \times H}{1000} \text{ kW}$$

for water  $\rho = 1000 \text{ kg/m}^3$

**(b) Mechanical efficiency**

$$m = \frac{\text{Power at the shaft of the turbine}}{\text{Power delivered to the runner}}$$

$$= \frac{S.P.}{R.P.}$$

**(c) Volumetric efficiency**

$$v = \frac{\text{Volume of water actually striking runner}}{\text{Volume of the water supplied to the turbine}}$$

**(d) Overall Efficiency**

$$o = \frac{\text{Power at the shaft of the turbine}}{\text{Power supplied at the inlet of the turbine}}$$

$$= \frac{S.P.}{W.P.}$$

$$= \frac{S.P.}{R.P.} \times \frac{R.P.}{W.P.}$$

$$o = m \times h$$

### PELTRON WHEEL (OR TURBINE)

- The peltron wheel or peltron turbine is a tangential flow impulse turbine. The water strikes the runner along the tangent of the runner.
- The energy available at the inlet of the turbine is only kinetic energy.
- The pressure at the inlet & outlet of the turbine is atmospheric.
- This turbine is used for high heads

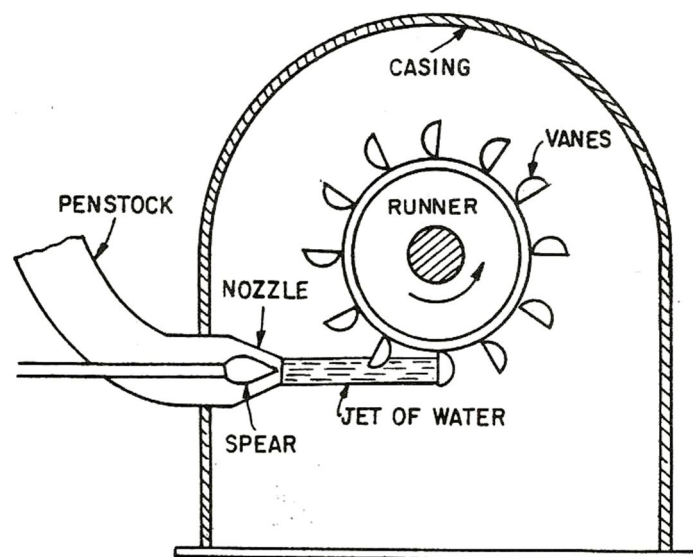

#### Constructions

The main parts of the peltron turbine are

- Nozzle & Flow Regulating Arrangement
- Runner and Buckets
- Casing
- Breaking jet

#### 1. Nozzle & Flow Regulating Arrangement:

The amount of water striking the buckets of the runner can be controlled by providing a spear in the nozzle. The spear is conical and operated by hand wheel



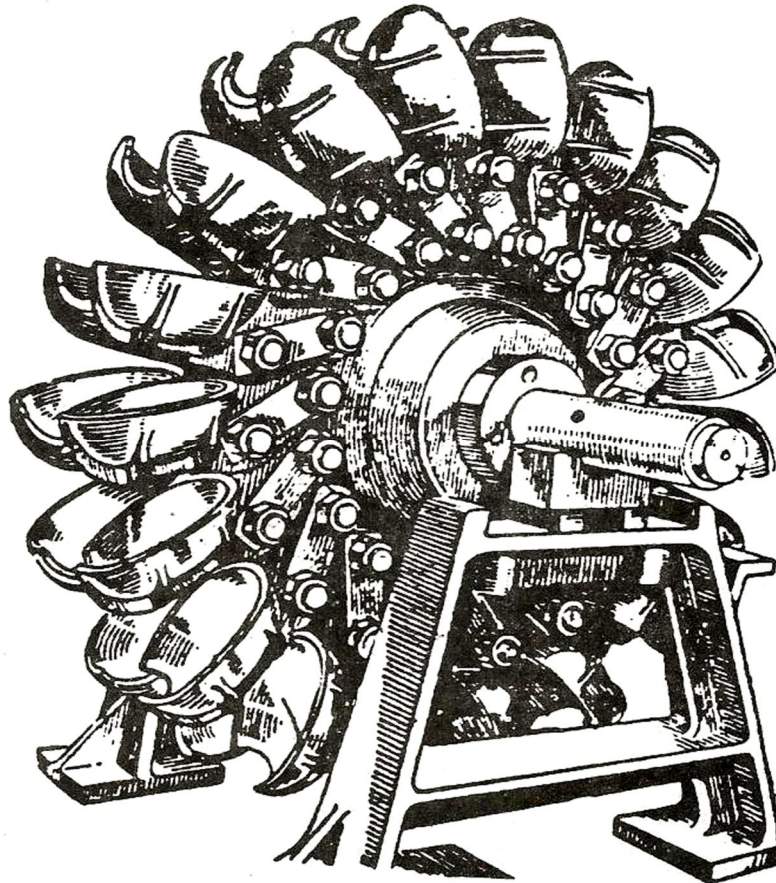
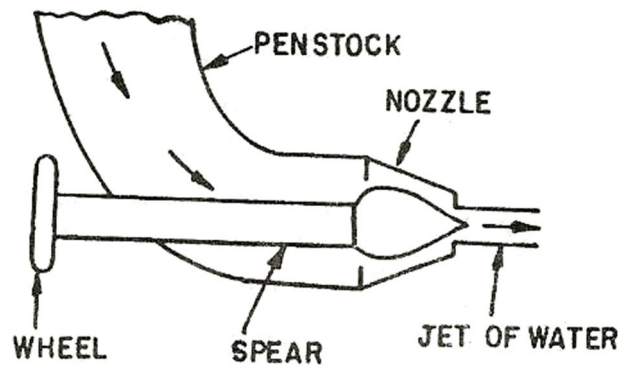

When spear is pushed Forward, the amount of water striking is reduced and when spear is pushed back, the amount of water striking the runner is increased

**2. Runner and Buckets :**

- The runner of the pelton wheel consists of a circular disc on the periphery of which a number of buckets evenly spaced are fixed
- The shape of the bucket is of a double hemispherical cup and bowl
- Each bucket is divided into two symmetrical parts by a dividing wall which is known as splitter
- The buckets are made of cast iron, cast steel bronze or stainless steel depending upon the head at inlet.
- The splitter divides the jet into two equal parts and the jet gets deflected through 160° or 170°

**3. Casing:**

- The function of the casing is to prevent the splashing of the water and to discharge water to tail race.
- It is made of cast iron or fabricated steel plates

**4. Breaking jet :**

When the nozzle is completely closed by moving the spear in forward direction, the amount of water striking the runner reduces to zero. But due to inertia the runner goes on revolving for a long time. To stop the runner in short time a small nozzle is provided which directs the jet of water on the back of the vanes. This jet is called breaking jet.

## VELOCITY TRIANGLES & WORK DONE FOR PELTRON WHEEL:

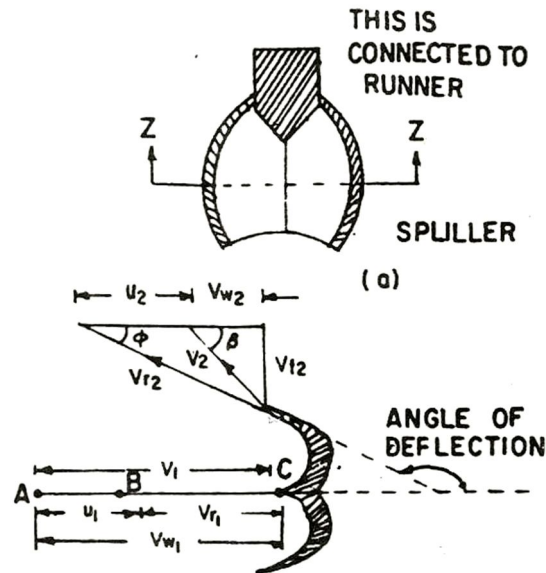

The jet of water strikes the bucket at the splitter. Which splits up the jet into two parts. The splitter is the splits up the jet into two parts. The splitter is the inlet tip & outer edge of the bucket is the outlet tip of the bucket.

The inlet & outlet velocity triangles are shown in the above figure.

Let  $H$  = net head outing on the pelton wheel

$$= H_g - h_f$$

Where  $H_g$  = Gross head      $h_f = \frac{4FLV^2}{D^*2g}$

$D^*$  = Diametre of penstock

$D$  = Diametre of wwheel

$N$  = Speed of the wheel in r.p.m.

$d$  = diameter of the jet

$$V_1 = \text{Velocity of jet} = \sqrt{2gh}$$

$$u = u_1 = u_2 = \frac{\pi DN}{60}$$

Velocity triangle at inlet is straight line where

$$V_{r1} = V_1 - u_1 = V_1 - u$$

$$V_{w1} = V_1$$

$$\alpha = 0 \quad \& \quad \theta = 0$$

For velocity triangle at out let, we have

$$V_{r2} = V_{r1} \& \quad V_{w2} = V_{r2} \cos \beta - u_2$$

The force exerted by the jet in the direction of motion is

$$F_x = \rho a v_1 (v_{w1} + v_{w2})$$

(+ve sign is taken as  $\beta$  is acute)

Mass of water striking =  $\rho a v_1$  [as series of vanes are there]

$$\text{Area of jet} = \frac{\pi}{4} d^2$$

Work done by the jet on the runner per second

$$= F_x \times u$$

$$= \rho a v_1 (v_{w1} + v_{w2}) \times u$$

Power given to the runner by the jet

$$\frac{\rho a v_1 [v_{w1} + v_{w2}] \times u}{1000} \text{ kw}$$

Work done/sec/ unit weight of fluid striking/sec

$$= \frac{\rho a v_1 [v_{w1} + v_{w2}] \times u}{\rho a v_{r1} \times g}$$

$$= \frac{[v_{w1} + v_{w2}] \times u}{g}$$

Energy supplied to the jet at inlet is the form of kinetic energy and is equal

to  $\frac{1}{2} m v^2$

$$\text{K.E} = \frac{1}{2} (\rho a v_1) v_1^2$$

$$= \frac{1}{2} \rho a v_1^3$$

**Hydraulic Efficiency:**

$$h = \frac{\text{Work done/sec}}{\text{Kinetic energy/sec}}$$

$$= \frac{2[v_{w1} + v_{w2}] \times u}{v_1^2}$$

$$V_{w1} = V_1,$$

$$V_{r1} = V_1 - u = V_1 - u \quad V_{r2}$$

$$V_{w2} = V_{r2} \cos \phi - u$$

$$= (V_1 - u) \cos \phi - u \quad (V_{r2} = V_1 - u, u_2 = u_1 = u)$$

Substituting the values of  $V_{w1}$  &  $V_{w2}$

$$h = \frac{2[v_1 + (v_1 - u) \cos \phi - u] \times u}{v_1^2}$$

$$= \frac{2(v_1 - u)[1 + \cos \phi] \times u}{v_1^2}$$

**Condition for maximum Efficiency**

the efficiency will be maximum when

$$\frac{d h}{d u} = 0$$

$$\Rightarrow \frac{d \left[ \frac{2(v_1 - u)[1 + \cos \phi] \times u}{v_1^2} \right]}{d u} = 0$$

By solving

$$\Rightarrow u = \frac{V_1}{2}$$

**Maximum Efficiency:**

$$\text{max} = \frac{[1 + \cos \phi]}{2}$$

**Points to be remembered for pelton wheel:**

1. The velocity of the jet at inlet is given by  
 $V_1 = C_v \sqrt{2gh}$  Where  $C_v$  = co-efficiency of velocity = 0.98 or 0.99  
 $H$  = Net head on turbine.
2. the velocity of wheel ( $u$ ) is given by  $u = \phi \sqrt{2gh}$  where  $\phi$  = speed ratio. The value of speed ratio varies from 0.43 to 0.48
3. the angle of deflection of the jet through buckets is taken at  $165^\circ$  if an angle of deflection is given.
4. the mean diameter or the pitch diameter  $D$  of the pelton wheel is given by

$$u = \frac{\pi DN}{60} \text{ or } D = \frac{60u}{\pi N}$$

5. **jet Ratio.** It is defined as the ratio of the pitch diameter ( $D$ ) of the pelton wheel to the diameter of the jet ( $d$ ). It is denoted by 'm' and is given as

$$m = \frac{D}{d} \text{ (= 12 for most cases)}$$

6. number of buckets on a runner is given by

$$Z = 15 + \frac{D}{2d} = 15 + 0.5m$$

Where  $m$  = jet ratio.

7. **Number of jets.** It is obtained by dividing the total rate of flow through the turbine by the rate of flow of water through a single jet.

## FRANCIS TURBINE

Francis turbine is a inward flow reaction turbine having radial discharge at outlet

### Radial flow reaction turbine:-

Radial flow turbines are those turbines in which the water flows in the radial direction. The water may flow radially from outward to inward or from inward to outward

Reaction turbines means that the water of the inlet of the turbine poses kinetic energy as well as pressure energy

Construction

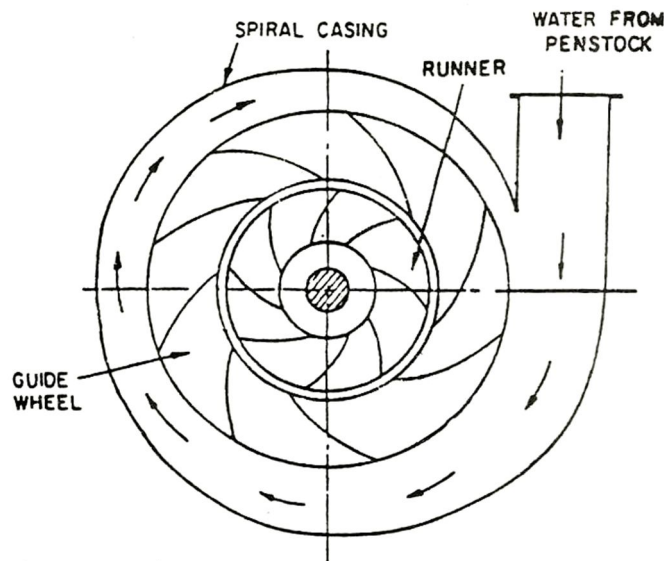

Main parts of a radial flow reaction turbine:

The main parts of a radial flow reaction turbine are

1. Casing
2. Guide mechanism
3. Runner
4. Draft Tube

**Casing:**

In case of reaction turbine casing and runner are always full of water the water from the penstocks enter the casing which is of spherical shape in which the cross section of the casing goes on decreasing gradually. The casing is made of concrete, cast steel or plate steel

**Guide Mechanism**

It consists of stationary circular wheel all round of the turbine. The stationary guide vanes are fixed on the guide mechanism. The guide vanes allow the water to strike the vanes fixed on the runner without shock at inlet, by watering the adjacent vanes of guide mechanism. The amount of water striking the runner can be varied

**Runner**

It is a circular wheel on which a series of radial curve vanes are fixed. The radial curve vanes are so shaped that the water enters and leaves the runner without shock. The runners are made up of cast steel cast iron or stainless steel. They are fixed to the shaft.

**Draft tube:**

The pressure at the exit of the runner of a reaction turbine is generally less than the atmospheric pressure. The water at exit cannot be directly discharge to the tail race. A tube or pipe of gradually increasing area is used for discharging water from the exit of the turbine to the tail race. This tube of increasing area is called draft tube.

**Inward flow reaction turbine:-**

- In this case the water flows from outward to inward through the runner.
- In this case the water from the casing enters the stationary guide wheel
- The guiding wheel consists of guide vanes which direct the water to enter the runner which direct the water to enter the runner which consists of moving vanes.
- The water flows over the moving vanes in the inward radial direction and is discharged at the inner diameter of the runner.
- The outer diameter of the runner is the inlet and the inner diameter of the runner is the outlet.



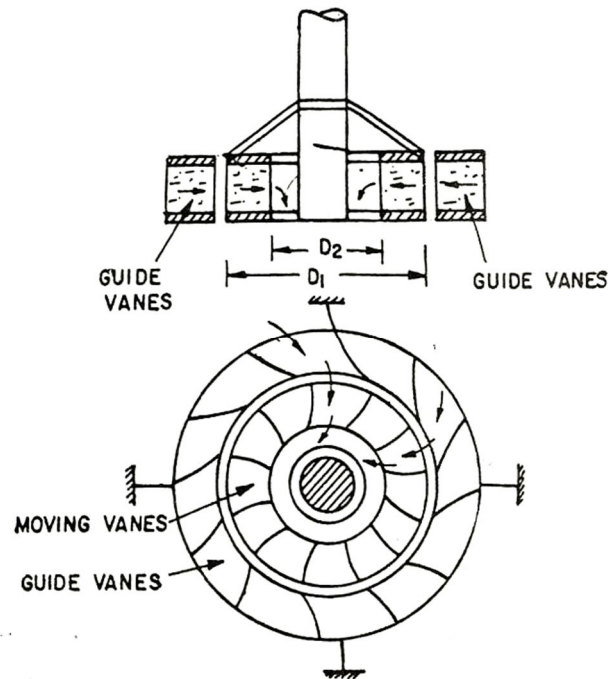

### Velocity triangle and work done :-

The work done per second on the runner by water for radially curved vanes is

$$V_1 \rho a [V_{w1} U_1 \pm V_{w2} U_2]$$

$$= \rho Q [V_{w1} U_1 \pm V_{w2} U_2]$$

The above equation also represents the energy transfer per second to the runners. where

$V_{w1}$  = velocity of whirl at inlet

$V_{w2}$  = velocity of whirl at outlet

$U_1$  = tangential velocity of wheel at inlet

$$= \frac{\pi D_1 N}{60}$$

$U_2$  = tangential velocity of wheel at outlet

$$= \frac{\pi D_2 N}{60}$$

$D_1$  = diameter of wheel at inlet

$D_2$  = diameter of wheel at outlet

The work done per second per unit weight of water per second

$$\begin{aligned}
 &= \frac{\text{work done per second}}{\text{weight of water striking per second}} \\
 &= \frac{\rho Q [V_{w1}U_1 \pm V_{w2}U_2]}{\rho Q \times g} \\
 &= \frac{1}{g} [V_{w1}U_1 \pm V_{w2}U_2]
 \end{aligned}$$

The equation is known as Euler's equation of hydro dynamic machine

### Special cases:-

If  $\beta$  is an obtuse angle ,  $\beta > 90^\circ$

$$\text{Work done per second} = \frac{1}{g} [V_{w1}U_1 - V_{w2}U_2]$$

➤ If  $\beta = 90^\circ$ ,  $V_{w2} = 0$

➤ Work done per second =  $\frac{1}{g} [V_{w1}U_1]$

### Hydraulic efficiency:-

$$\begin{aligned}
 h &= \frac{R.P}{W.P} = \frac{\frac{W}{1000g} [V_{w1}U_1 \pm V_{w2}U_2]}{\frac{W \times H}{1000}} \\
 &= \frac{[V_{w1}U_1 \pm V_{w2}U_2]}{gH}
 \end{aligned}$$

Where R.P = runner power

W.P = water power

If discharge is radial at outlet , then  $V_{w2} = 0$

$$h = \frac{V_{w1}U_1}{gH}$$

**Important point to be remembered :-****(i) speed ratio:-**

The speed ratio is defined as  $= \frac{u_1}{\sqrt{2gH}}$

where  $u_1$  = triangular velocity of wheel at inlet.

**(ii) Flow ratio :-**

The ratio of the velocity of flow at inlet  $V_{f1}$  to the velocity given  $\sqrt{2gH}$ , it is known as flow ratio.

Where  $H$  = Head on turbine

**(iii) Discharge of the turbine:-**

The discharge through a reaction turbine is given by

$$Q = \pi D_1 B_1 V_{f1} = \pi D_2 B_2 V_{f2}$$

Where

$D_1$ =Diameter of runner at inlet

$D_2$ =Diameter of runner at outlet

$B_1, B_2$ =Width of runner at inlet & outlet respectively

$v_{f1}, v_{f2}$ =Velocity of flow at inlet & outlet respectively

If thickness of vanes are taken into consideration then discharge will be  $(\pi D_1 - nt)B_1 v_{f1}$  where

$N$ =number of vanes

$T$ =thickness of each vane

**(iv) The head(H) on the turbine is given by**

$$H = \frac{p_1}{\rho g} + \frac{V_1^2}{2g}$$

Where  $p_1$ = pressure at inlet

**(v) Radial Discharge:-**

Radial discharge at outlet means  $B=90^\circ, V_{w2}=0$

Radial discharge at inlet means

$$\alpha = 90, V_{w1} = 0$$

If there is no loss of energy when water flows through the vanes then we have

$$\frac{H - V_2^2}{2g} = \frac{1}{g} [V_{w1}U_1 \pm V_{w2}U_2]$$

### Outward radial flow reaction turbine:-

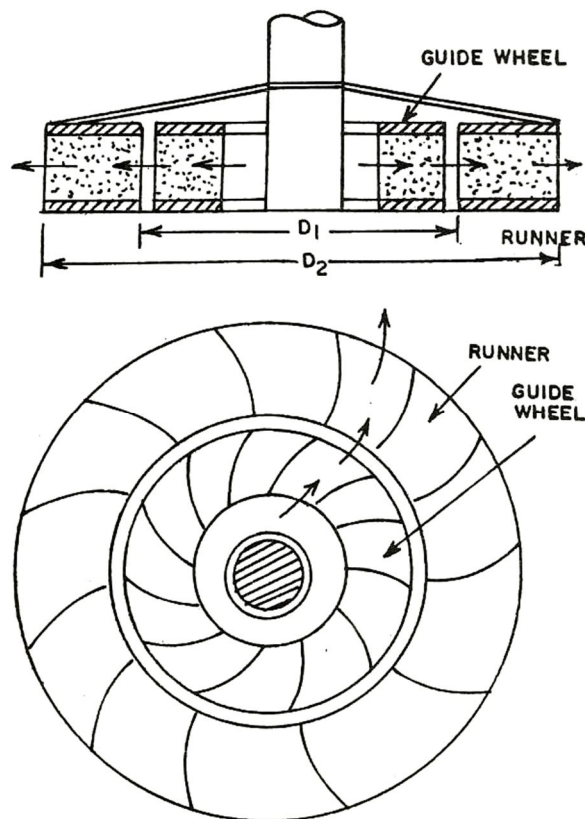

If the water flows from inward to outward through the runner, then that turbine is known as outward flow reaction turbine.

In this case at inlet of the runner is at the inner diameter of the runner, the tangential velocity at inlet will be less than that of at outlet.  $U_1 < U_2$  as  $D_1 > D_2$

The velocity triangles at inlet and outlet, work done by water on runner per second, the horse power developed, the hydraulic efficiency is similar as inward flow reaction turbine.

**Francis turbine :-**

The inward flow reaction turbine having radial discharge at outlet is known as Francis turbine. The water enters the runner of the turbine in radial direction at outlet and leaves in the axial direction at inlet of the runner. So the modern Francis turbine is a mixed flow type turbine.

**Axial flow reaction turbine :-**

- It the water flows parallel to the axis of the rotation of the shaft, the turbine is known as axial flow turbine.
- For axial flow reaction turbine, the shaft of the turbine is vertical.
- The lower end of the shaft is made larger which is known as 'hub' or 'boss'.
- The vanes are fixed on the hub act as a runner for axial flow reaction turbine.

**Types of axial flow reaction turbine**

- 1) Propeller turbine: when the vanes fixed on the hub are not adjustable, the turbine is known as propeller turbine.
- 2) Kaplan turbine: when the vanes fixed on the hub are adjustable, the turbine is known as Kaplan turbine.

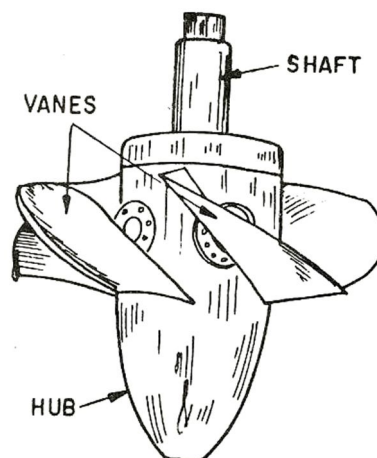
**Kaplan turbine:**

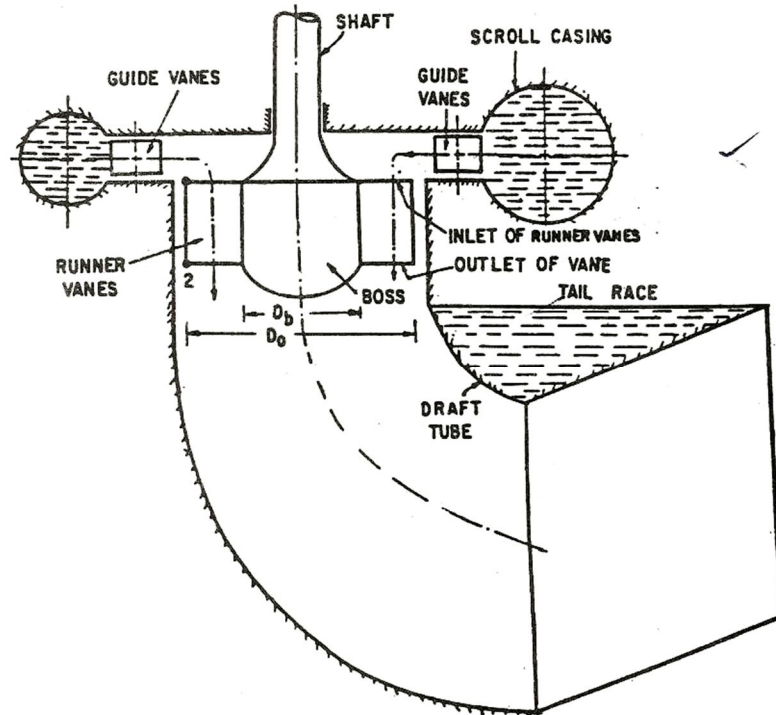

- 1) when the vanes fixed on the hub are adjustable, the turbine is known as Kaplan turbine.
- 2) This turbine is suitable. Where larger quantity of water at low head is available.
- 3) Kaplan turbine consists of a hub fixed to the shaft.
- 4) On the hub the adjustable vanes are fixed.

**Main parts of a Kaplan turbine :**

- 1) Scroll casing
- 2) Guide vanes mechanism
- 3) Hub with vanes or runner of the turbine
- 4) Draft tube

**Work mg**

- 1) The water from penstock enters the scroll casing and then moves to the guide vanes.
- 2) From the guide vanes, the water turns through  $90^\circ$  and flows axially through the runner.
- 3) The discharge through the runner is given by
- 4) The outlet and inlet velocity triangles are drawn at the extreme edge of the runner and similar as reaction turbines.

**Important points for Kaplan turbine**

- 1) The peripheral velocity at inlet and outlet are equal
- 2) Velocity of flow at inlet and outlet are equal
- 3) Area of flow at inlet = area of flow at outlet

**Governing of turbines :**

- 1) The governing of a turbine is defined as the operation by which the speed of the turbine is kept constant under all conditions of working
- 2) By means of a governor the rate of flow through the turbine is automatically regulated according to the changing load conditions on the turbine.
- 3) Governing is necessary as a turbine is directly coupled to an electric generator, which is required to run at constant speed under all fluctuating loads condition.
- 4) This is only possible when the speed of the generator under all changing load condition is constant and for that the speed of the turbine should be constant.
- 5) If the turbine or the generator is to run at constant speed, the rate of flow of water to the turbine should be decreased till the speed becomes normal.
- 6) This process by which the speed of the turbine is kept constant under varying conditions of load is called governing.

**Draft tube:**

- 1) Draft tube is a pipe of gradually increasing area which connects the outlet of the runner to the tail race.
- 2) It is used for discharging water from the exit of the turbine to the tail race. This pipe of gradually increasing area is called draft tube.
- 3) One end of the draft tube has the following two purposes.
- 4) It permits a negative head to be established at the outlet of the runner and thereby increases the net head on the turbine. The turbine may be placed above the tail race without any loss of net head and hence the turbine may be inspected properly.
- 5) It converts a large proportion of the kinetic energy ( $v^2/2g$ ) rejected at the outlet of the turbine into useful pressure energy. Without the draft tube the K.E. rejected at the outlet of the turbine will go waste to the tail race.

**Types of draft tube :**

- 1) The following are the important types of draft tubes which are commonly used.
  - I. Conical draft tubes
  - II. Simple elbow tubes
  - III. Moody spreading tubes
  - IV. Elbow draft tubes with circular inlet and rectangular outlet.

**Criteria for selection of hydraulic turbine**

The main selection criteria of hydraulic turbine is specific speed also the performance

Of a turbine can be predicted by knowing specific speed .

Types of turbine for different specific speed .

Type of turbine	specific speed	
	M.K.S	S.I
Pelton wheel with single jet	10 to 35	85 to 30
Pelton wheel with 2 or more jets	35 to 60	30 to 51
Francis turbine	60 to 300	51 to 225
Kaplan or propeller turbine	300 to 1000	255 to 860

**Specific speed**

It is defined as the speed of a turbine which is identical in shape, geometrical dimensions,

blade angles, gate openings etc, with the actual turbine but of such a size that it will develop

Unit power when working under unit head .

It is denoted by the symbol  $N_s$

The specific speed is used in comparing the different types of turbine as every type of turbine has different specific speed



**Numerical problems**

Q.1. A Pelton wheel has a mean bucket speed of 10 m/s. The buckets deflect the jet through an angle of  $160^\circ$ . Calculate the power given by water to the runner and the hydraulic efficiency of the turbine. Assume coefficient of velocity as 0.98.

Q.2. An inward flow reaction turbine has external and internal diameters as 0.9 m and 0.45 m respectively. The turbine is running at 200 rpm and width of turbine at inlet is 200 mm. The velocity of flow through the runner is constant and is equal to 1.8 m/s. The guide blades make an angle of  $10^\circ$  to the tangent of the wheel and determine.

- I. The absolute velocity of water at inlet of runner.
- II. The velocity of whirl at inlet
- III. Relative velocity at inlet
- IV. The runner blade angle
- V. Width of the runner at outlet
- VI. Mass of water flowing through the runner/sec.
- VII. Head at the inlet of the turbine
- VIII. Power developed and hydraulic efficiency of the turbine.

## Chapter - 8

# Hydraulic Pumps

Syllabus:

**8.1 Definition and classification of pumps**

**8.2 Centrifugal Pumps**

**Construction and working principles, velocity diagram of a single impeller, work done and efficiency (Numerical Problems)**

**Concept of multistage centrifugal pumps**

**Cavitation-Causes and its effect**

**8.3 Reciprocating Pumps**

**Construction and working principle of single acting and double acting reciprocating pumps**

**8.4 Concept of slip and negative slip**

The hydraulic machine which converts mechanical energy into hydraulic energy are called pumps. The hydraulic energy is in the form of pressure energy

The pumps are of two types

1. Centrifugal pump
2. Reciprocating pump

### CENTRIFUGAL PUMP:-

The centrifugal machine which converts mechanical energy into pressure energy by means of centrifugal force acting on the fluid is known as centrifugal pump.

- The centrifugal pump acts as a reversed of an inward radial flow reaction turbine.
- The centrifugal pump works on the principle of forced vortex flow which means that when a certain mass of liquid is rotated by an external torque, the rise in pressure head of the rotating liquid takes place. The rise in pressure head at any point is proportional to the square of tangential velocity of the liquid at that point i.e,  $V^2/2g$  or  $\omega^2 R^2/2g$

### MAIN PARTS:-

The main parts of a centrifugal pump are ;

1. Impeller
2. Casing
3. Suction pipe with a foot valve and strainer
4. Delivery pipe

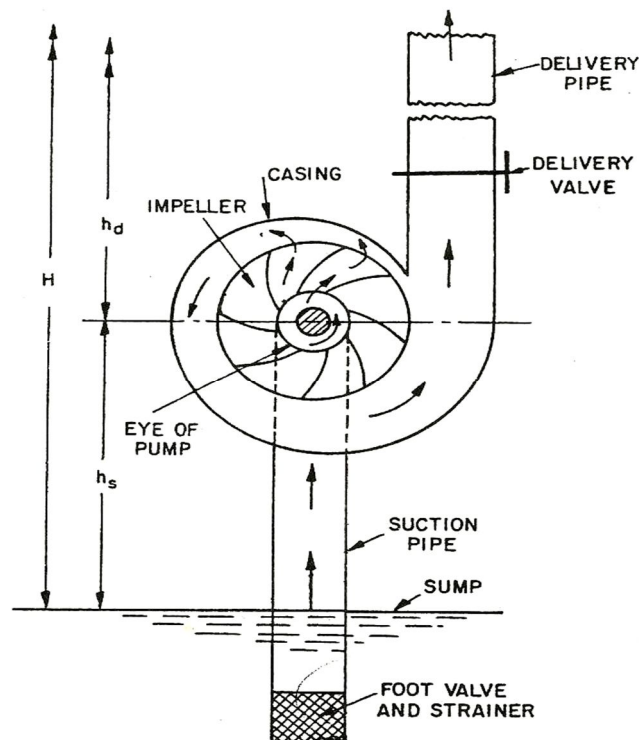

**1. Impeller:-**

The rotating part of a centrifugal pump is called impeller. It consists of series of backward curved vanes . The impeller is mounted on a shaft which is connected to the shaft of an electric motor.

**2. Casing:-**

The casing of a centrifugal pump is similar to the casing of a reaction turbine. It is an air tight passage surrounding the impeller. It is designed in such a way that the kinetic energy of the water discharged at the outlet of the impeller is converted into pressure energy before the water leaves the casing and enters the delivery pipe

- There are three types of casing are commonly used.;
- (i) Volute casing
- (ii) Vortex casing
- (iii)Casing with guide blades

**Volute casing:-**

- It is a spiral type in which area of flow increases gradually.
- The increase in area of flow decrease velocity of flow and decrease in velocity
- Increases the pressure of the water flowing through the casing.

**Vortex casing:-**

- If a circular chamber is introduced between the casing and impeller , the casing is called vortex casing.
- By introducing the circular chamber , the loss of energy due to the formation of eddies is reduced to a considerable extent. Thus the efficiency of the pump is more than the efficiency when only volute casing is provided.

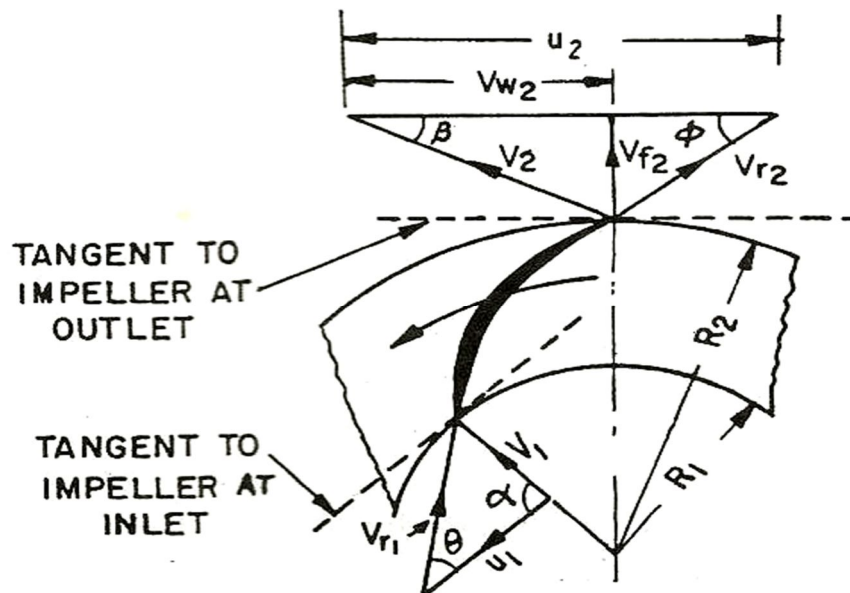
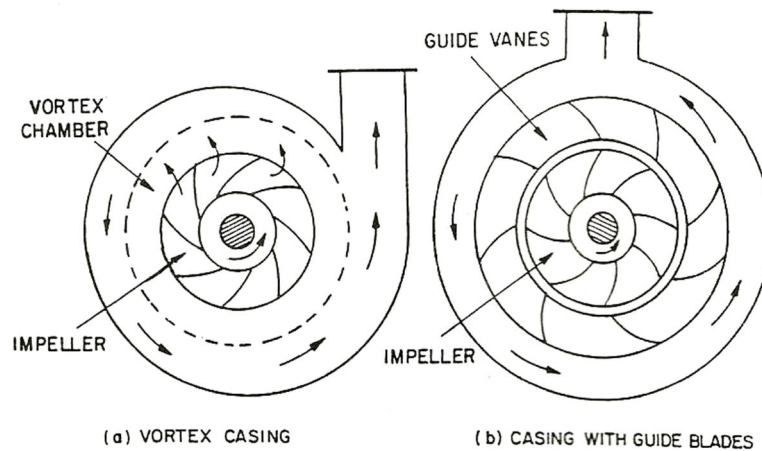

### Casing with guide blades:-

The casing in which the impeller is surrounded by a series of guide blades mounted on a ring which is known as diffuser.

The guide vanes are designed in such a way that the water from the impeller enters the guide vanes without shock. Also the area of the guide vanes increases thus reducing the velocity flow through guide vanes and consequently increasing the pressure through the surroundings casing which is in most of the cases concentric with the impeller.

### 3. Suction pipe with a foot valve and a strainer:-

- A pipe whose one end is connected to the inlet of the impeller and other end dips into the water in a sump is known as suction pipe.
- A foot valve which is a non return valve or one way type of valve is fitted at the lower end of the suction pipe. It will open only upward direction.
- A strainer is also fitted to filter the water.

### 4. Delivery pipe:-

The pipe whose one end is connected to the outlet of the pump and other end delivers water at a required height is known as delivery pipe.

### WORK DONE BY THE CENTRIFUGAL PUMP ON WATER:-

In case of centrifugal pump work is done by the impeller on the water. The water enters the impeller radially at inlet for best efficiency of the pump which means the absolute velocity of water at inlet makes an angle of  $90^\circ$  with the direction of motion at inlet.

Hence  $\alpha = 90^\circ$ ,  $V_{w1} = 0$

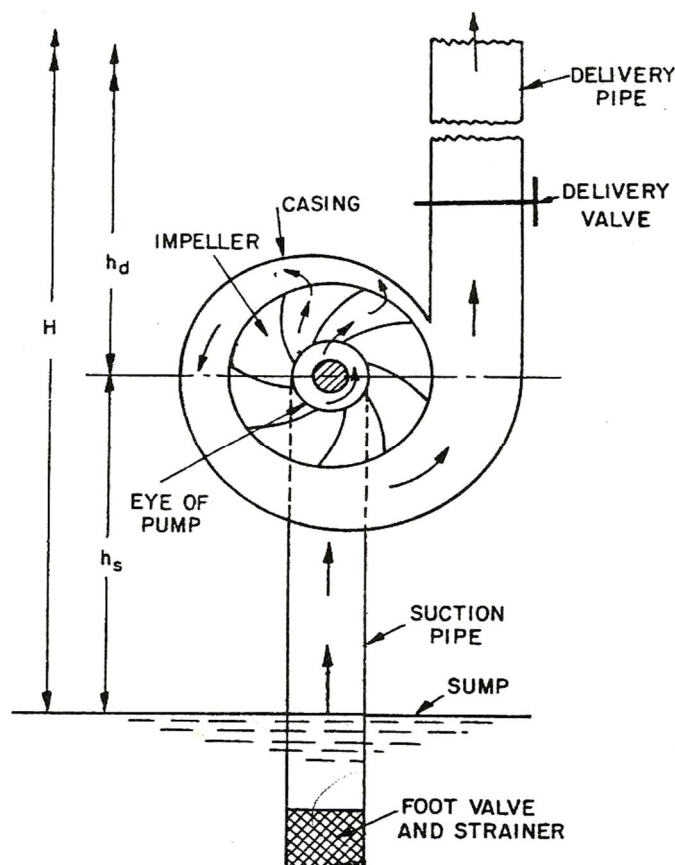

Let  $N$  = speed of impeller in r.p.m

$D_1$  = diameter of impeller at inlet.

$U_1$  = tangential velocity of impeller at

$$= \frac{\pi D_1 N}{60}$$

$D_2$  = diameter of impeller at outlet

$U_2$  = tangential velocity of impeller at outlet

$$= \frac{\pi D_2 N}{60}$$

A centrifugal pump is the reverse of a radially inward flow reaction turbine.

But, in case of a radially inward flow reaction turbine, the work done by the water on the runner per second unit weight of the water striking per second

$$= \frac{1}{g} [V_{w1} U_1 - V_{w2} U_2]$$

Work done by the impeller on the water per second per unit weight of the water striking per second.

= - (work done in case of turbine)

$$= - \frac{1}{g} [V_{w1} U_1 - V_{w2} U_2]$$

$$= \frac{1}{g} V_{w2} U_2$$

Work done by the impeller on water per second

$$= \frac{W}{g} (V_{w2} U_2)$$

$$= \rho Q (V_{w2} U_2)$$

$Q$  = volume of water flowing per second

$$= \pi D_1 B_1 V_{f1} = \pi D_2 B_2 V_{f2}$$

$B_1, B_2$  are width of impeller at inlet and outlet

$V_{f1}, V_{f2}$  are velocities of flow at inlet and outlet.

## DEFINITIONS OF HEADS AND EFFICIENCIES OF A CENTRIFUGAL PUMP:-

### 1. Suction head( $h_s$ ):-

It is the vertical height of the centre line of the centrifugal pump above the water surface in the tank or sump from which water is to be lifted. This height is also called suction lift.

### 2. Delivery head( $h_d$ ):-

The vertical distance between the centre line of the pump and the water surface in the tank to which water is delivered is known as delivery head.

### 3. Static head( $H_s$ ):-

The sum of suction head and delivery head is called static head. It is written as  $H_s = h_s + h_d$

### 4. Manometric head( $H_m$ ):-

The manometric head is defined as the head against which a centrifugal pump has to work.

(a)  $H_m =$  Head imparted by the impeller to the water – loss of head in the pump

$$= \frac{1}{g} V_{w2} U_2 - \text{loss of head in impeller casing}$$

$$= \frac{1}{g} V_{w2} U_2 \text{ if loss of pump is zero}$$

(b)  $H_m =$  total head at outlet of the pump – total head at the inlet of the pump

$$= \left( \frac{\rho_o}{\rho g} + \frac{V_o^2}{2g} + Z_o \right) - \left( \frac{\rho_1}{\rho g} + \frac{V_1^2}{2g} + Z_i \right)$$

$$\frac{\rho_o}{\rho g} = \text{pressure head at outlet of the pump} = h_d$$

$$\frac{V_o^2}{2g} = \text{velocity head at outlet of the pump}$$

$$= \text{velocity head in delivery pipe} = \frac{V_w^2}{2g}$$



$Z_0$  = vertical height of the outlet of the pump from datum line.

$\frac{P_i}{\rho g}, \frac{v_i^2}{2g}, Z_i$  are the corresponding values of pressure head, velocity head and datum head at the inlet of the pump

$$(c) \quad H_m = h_s + h_d + hf_s + hf_d + \frac{v_d^2}{2g}$$

$h_s$  = suction head

$h_d$  = delivery head

$hf_s$  = frictional loss in suction pipe

$hf_d$  = frictional head loss in delivering pipe

$V_d$  = velocity of water in delivering pipe

### **EFFICIENCIES OF A CENTRIFUGAL PUMP:-**

In case of centrifugal pump the power is transmitted from the shaft of the electric motor to the shaft of pump and then to the impeller. From the impeller power is given to the water. Thus, power is decreasing from the shaft of the pump to the impeller and then to the water.

- Manometric efficiency
- Mechanical efficiency
- Overall efficiency

### **Manometric efficiency:-**

The ratio of the manometric head to the head imparted by the impeller to the water is called manometric efficiency.

$$\begin{aligned} man &= \frac{\text{manometric head}}{\text{head imparted by impeller to water}} \\ &= \frac{H_m}{\frac{1}{g} V_{w2} U_2} \\ &= \frac{g.H_m}{V_{w2} U_2} \end{aligned}$$

The power is given to water at outlet of the pump

$$= \frac{W.H_m}{1000} \text{ kW}$$

$$= \frac{\phi \rho g H m}{1000} \text{ kw}$$

$$\text{Power at impeller} = \frac{\phi \rho (V_{w2} U_2)}{1000} \text{ kw}$$

$$m_{an} = \frac{\phi \rho g H m}{\phi \rho (V_{w2} U_2)}$$

$$= \frac{g.Hm}{V_{w2} U_2}$$

### **Mechanical efficiency:-**

The power at shaft of the centrifugal pump is more than the power available at the impeller of the pump. The ratio of the power available at the impeller to the power at the shaft of the pump is called mechanical efficiency

$$m = \frac{\text{power at impeller}}{\text{power at shaft}}$$

### **Overall efficiency:-**

It is defined as ratio of power output of the pump to the power input to the pump.

$$\eta_0 = \frac{W.P}{S.P}$$

$$= \frac{W.P}{I.P} \times \frac{I.P}{S.P}$$

$$\eta_0 = m_{an} \times m$$

### **MINIMUM SPEED FOR STARTING A CENTRIFUGAL PUMP:-**

If the pressure rise in the impeller is more than or equal to manometric head the centrifugal pump will start delivering water. Otherwise the pump will not discharged any water, though the impeller is rotating, the water in contact with the impeller is also rotating. This is the case of forced vortex.

The centrifugal head or head due to pressure rise in the impeller.

$$= \frac{W^2 r_2^2}{2g} - \frac{W^2 r_1^2}{2g}$$

$W_{r2}$  = tangential velocity of impeller at outlet =  $u_2$

$W_{r1}$  = tangential velocity of impeller at inlet =  $u_1$

$$\text{Head due to pressure rise} = \frac{u_2^2}{2g} - \frac{u_1^2}{2g}$$

The flow of water will commence only if head due to pressure rise

$\geq H_m$

$$\text{For minimum speed } \frac{u_2^2}{2g} - \frac{u_1^2}{2g} = H_m$$

$$man = \frac{g \cdot H_m}{V_{w2} U_2}$$

$$H_m = \frac{man V_{w2} U_2}{g}$$

$$\frac{u_2^2}{2g} - \frac{u_1^2}{2g} = \frac{man V_{w2} U_2}{g}$$

$$U_2 = \frac{\pi D_2 N}{60}, \quad U_1 = \frac{\pi D_1 N}{60}$$

$$\Rightarrow \frac{1}{2g} \left( \frac{\pi D_2 N}{60} \right)^2 - \frac{1}{2g} \left( \frac{\pi D_1 N}{60} \right)^2 = \frac{man V_{w2} U_2}{g} \cdot \frac{\pi D_2 N}{60}$$

$$\Rightarrow \frac{\pi N}{60g} \left[ \frac{\pi D_2^2 N}{120} - \frac{\pi D_1^2 N}{120} \right] = \frac{man V_{w2} U_2}{g} \cdot \frac{\pi D_2 N}{60}$$

$$\Rightarrow \frac{\pi N}{120} (D_2^2 - D_1^2) = man V_{w2} D_2$$

$$\Rightarrow N = \frac{man V_{w2} D_2 120}{\pi (D_2^2 - D_1^2)}$$

**MULTI STAGE CENTRIFUGAL PUMP:-**

If a centrifugal pump consists of two or more impellers, the pump is called a multistage centrifugal pump. The impeller may be mounted on the same shaft or on different shaft.

A multi stage pump is having 2 functions;-

- i. To produce a high head
- ii. To discharge a large quantity of liquid.

If a high head is to be developed , the impellers are connected in series while for discharging large quantity of liquid, the impellers are connected in parallel.

**MULTI STAGE CENTRIFUGAL PUMP FOR HIGH HEADS:-**

- For developing a high head, a number of impellers are mounted in series or on the same shaft.
- The water from suction pipe enters the first impeller at inlet and it discharges at outlet with increased pressure.
- The water with increased pressure from the outlet of the first impeller is taken to the inlet of the 2<sup>nd</sup> impeller with the help of connecting pipe.
- At the outlet of the 2<sup>nd</sup> impeller the presence of water will be more than the pressure of water at the outlet of the 1<sup>st</sup> impeller . thus, if more impellers are mounted on the same shaft, the pressure will be increased further.

$n$  = No. Of impeller mounted on the same shaft.

$H_m$ = head developed by each impeller.

Total head developed =  $n \times H_m$

**MULTI STAGE CENTRIFUGAL PUMP FOR HIGH DISCHARGE:-**

- For obtaining high discharge the pumps should be connected in parallel.
- Each of the pumps lifts the water from a common sump and discharges water to a common pipe to which delivery pipe of each pump are connected.

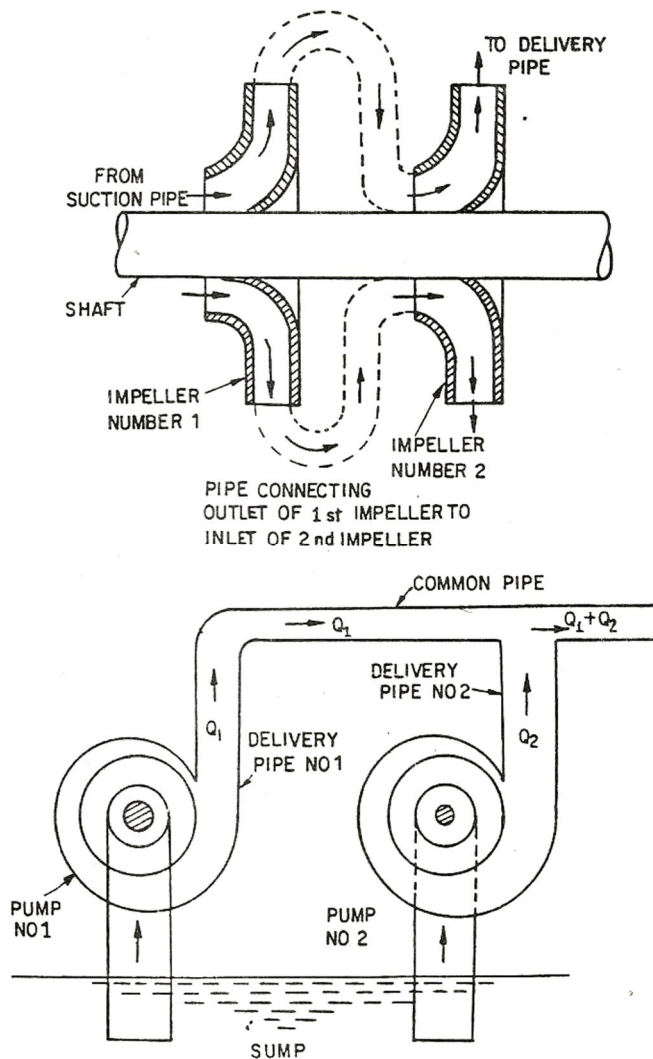

- Each pumps is working against the same head.
- $N$  = number of identical pumps are in parallel
- $Q$  = discharge through each pump
- Total discharge =  $n.Q$

**PRIMING:-**

- Priming is a centrifugal pump is defined as the operation in which the suction pipe, casing of the pump and a portion of the delivery pipe to the delivery valve is completely filled up from outside source with the liquid to be raised by the pump before starting the pump.
- Thus air from these parts of the pump is removed and these parts are filled with the liquid to be pumped.
- The work done by the impeller  $= \frac{1}{g} V_{w2} U_2$
- The head generated by the pump  $= \frac{1}{g} V_{w2} U_2$ . It is independent of the density . so when the pump is running in air the head generated is in terms of metre of air.
- If the pump is primed with water , the head generated is same meter of water. But as the density of air is very low. The generated head of air in terms of equivalent metre of water head is negligible. And hence the water may not be sucked from the pump. To avoid this difficulty, priming is necessary.

**COMPARISION BETWEEN CENTRIFUGAL PUMP AND RECIPROCATING PUMP:-**

<b><u>CENTRIFUGAL PUMP</u></b>	<b><u>RECIPROCATING PUMP</u></b>
➤ The hydraulic machine which converts mechanical energy into pressure energy by means of centrifugal force acting on the fluid is called centrifugal pump.	➤ The hydraulic machine which converts hydraulic energy into pressure energy by sucking liquid in a cylinder in which piston is reciprocating known as reciprocating pump.
➤ It occupies less floor space	➤ It occupies 6 to 8 times more floor space area than centrifugal pump.
➤ Installation is easy	➤ Installation is difficult
➤ Maintenance cost is less	➤ Maintenance cost is high.
➤ It requires priming	➤ It does not require priming.
➤ It is suitable for large discharge and small head.	➤ It is suitable for low discharge and high head