

## **CHAPTER 1**

### **INTRODUCTION**

#### **1.0 IMPORTANCE AND NECESSITY FOR PLANNED WATER SUPPLIES**

Next to the air, the other important requirement for human life to exist is water. Water is available in various forms such as rivers, lake, streams etc. The earliest civilizations organized on the banks of major river systems and required water for drinking, bathing, cooking etc. But with the advancement of civilization the utility of water enormously increased and now such a stage has come that without well organized public water supply scheme, it is impossible to run the present civic life and the develop the towns. The importance of water from only a quantity viewpoint was recognized from the earliest days and the importance of quality come to be recognized gradually in the later days. The earliest recorded knowledge of water quality and its treatment are found in Sanskrit literature “Sushuri Sanhita” compiled about 2000 B.C. It deals with storage of drinking water in copper vessels, exposure to sunlight, filtering through charcoal, sand etc.

The correlation between water quality and incidence of diseases was first established in 1849 by Dr. John snow when cholera appeared in London during the summer and 14,600 deaths were reported. But Dr. snow unable to convince the authorities and public with the evidence of available data. The water borne diseases like typhoid, dysentery, cholera etc the concept of water borne diseases was well accepted by 1900. Another striking example was reported from Uttarpradesh by W.H.O (World Health Organisation) in 1963, there the death rate by chorera decreased by 74.1%, Thyphoid fever by 63.6% , by dysentery 23.1% and diarria by 63.6%. All these were achieved by drinking water treatment.

#### **1.1 NEED FOR PROTECTED WATER SUPPLY**

Protected water supply means the supply of water that is treated to remove the impurities and made safe to public health. Water may be polluted by physical and bacterial agents. Water is also good carrier of disease causing germs. The causes of outbreak of epidemics are traced to pollute water and poor sanitation hospital are continued to be flooded with the sick due to ignorance about health continues to be profound. However during the last few decades, improvements in the public health protection by supplying safe water and sanitation to all the people in the developing countries. In 1977, united nations declare to launch a movement known as “HEALTH FOR ALL BY THE YEAR 2000 A.D.” India is also a signatory to that conference. The working group appointed by the planning commission while suggesting strategies for achieving the above goal emphasized that potable water from protected water supply should be made available to the entire population. Pure and whole some water is to be supplied to the community alone can bring down the morbidity rates

Sl.No.	Description	India 1970-75	U.S.A 1970-75
1	Average per capita G.N.P.	133	7024
2	Infant mortality rate (per thousand)	129	15
3	Life Expectancy (years)	49	73
4	Literacy	34	99

**Table 1.1**

From the above table 1.1, the literacy rate in U.S.A. is high and all the citizens received protected water supply. Hence the infant mortality is very low

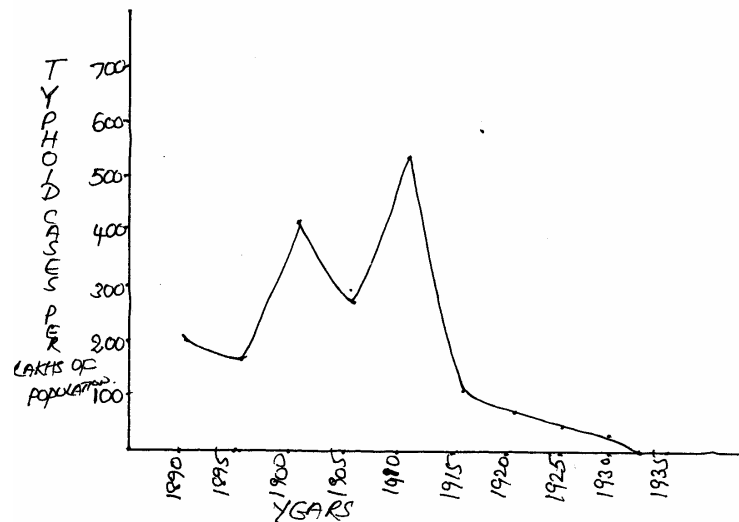

**Fig 1.1**

The graph in fig1.1 shows the fall in typhoid cases in U.S.A after treatment of water by filtration from 1906 and then chlorinating from 1913. At present, only 16 percent of towns in our country are equipped with water supply works serving about five percent of population of the whole of country. India has get to make serious efforts to make the treated water available to the most of its population so as to minimise the water borne diseases. Therefore protected water supply is a SIN QUO NON of public health of a community.

The objectives of the community water supply system are

1. to provide whole some water to the consumers for drinking purpose.
2. to supply adequate quantity to meet at least the minimum needs of the individuals
3. to make adequate provisions for emergencies like fire fighting, festivals, meeting etc
4. to make provision for future demands due to increase in population, increase in standard of living, storage and conveyance

5. to prevent pollution of water at source, storage and conveyance
6. to maintain the treatment units and distribution system in good condition with adequate staff and materials
7. to design and maintain the system that is economical and reliable

## **1.2 WHOLE SOME WATER**

Absolutely pure water is never found in nature and which contains only two parts of hydrogen and one part of oxygen by volume. But the water found in nature contains number of impurities in varying amounts. The rainwater which is originally pure, also absorbs various gases, dust and other impurities while falling. This water when moves on the ground further carries silt, organic and inorganic impurities. The removal of the turbidity, odour and smell is considered as good and removal of dissolved substances is considered as “chemically pure”. But removal of substances like calcium, magnesium Iron, Zinc etc completely is not good for health. These minerals are required for tissue growth and some act as propylatic in preventing diseases. Therefore wholesome water is defined as the water which containing the minerals in small quantities at requisite levels and free from harmful impurities Chemically pure water is also corrosive but not whole some water. The water that is fit for drinking safe and agreeable is called potable water.

The following are the requirements of wholesome water.

1. It should be free from bacteria
2. It should be colourless and sparkling
3. It should be tasty, odour free and cool
4. It should be free from objectionable matter
5. It should not carrode pipes
6. It should have dissolved oxygen and free from carbonic acid so that it may remain fresh

## **1.3 STATUS OF PROTECTED WATER SUPPLY IN INDIA**

Lack of safe drinking water in India is still a problem in many areas of the country. As per the U.N. report (1983), town and cities only 86% of the urban population have some provision for protected water supplies. Only one village out of ten has safe drinking water. It is important to note that 80% of India’s population live in villages and only 6 crores have access for safe water.

## **1.4 PLANNING AND EXECUTION OF MODERN WATER SUPPLY SCHEMES**

After british rule in our country, investments made in successive five year plans for planned development towards urban and Rural water supply and sanitation. Because of shortage of funds and some other reasons were responsible for slow growth of water supply facilities during the last five year plans.

There are many central, state and International agencies coordinating and executing the urban and rural water supply schemes in the country

1. Central public health and environment organization under the ministry of works and housing formulates schemes and provide assistance to states planning and development.
2. National environment engineering research institute (NEERI) is a research institute of Govt. of India, conducts water quality surveys and suggests treatment processes and also provides design of treatment and distribution system
3. CSIR laboratories (council of scientific and industrial research) provide testing facilities for water quality maintenance.
4. Central ground water board, Geological survey of India, national geographical research institute (NGRI) are engaged afflicted by fluoride Iron, Manganese etc.
5. Technology missions were launched by Govt. of India in 1986 with submissions on control of flows
6. Bharat Heavy Electricals Limited is providing technology in such special processes like Reverse Electro-Dialysis.
7. Public Health Engineering Departments undertake execution of large schemes for water supply and sanitation.
8. State ground water department evaluates the quality and quantity of ground water all over the state.
9. Panchayat Raj Engineering department of state Govt. is the model agency for providing water supply and sanitation facilities in rural and urban panchayats.
10. A.P. State council of science and technology is engaged in assessing the status and quality of drinking water availability and requirements in selected areas.
11. Medium and major irrigation departments of Govt. undertake multipurpose schemes in the state with component of water supply along with Hydroelectric, irrigation, navigation, tourism and other services.
12. Educational institutions – many engineering colleges offer course in environmental engineering water supply and sanitary engineering at degree and postgraduate levels. Polytechnics and vocational courses conduct courses in water supply engineering to train the technicians and engineers to the growing demand
13. International organizations like UNICEF (United Nations Health Organization) provide technical assistance and knowledge on water supply schemes working in specific problem areas.
14. There are many Non-Governmental organizations (N.G.O) like water development society, environmental protection societies operating in limited areas with donations and contributions by public and Govt.

The complete outlines of water supply scheme is as shown in fig. 1.2

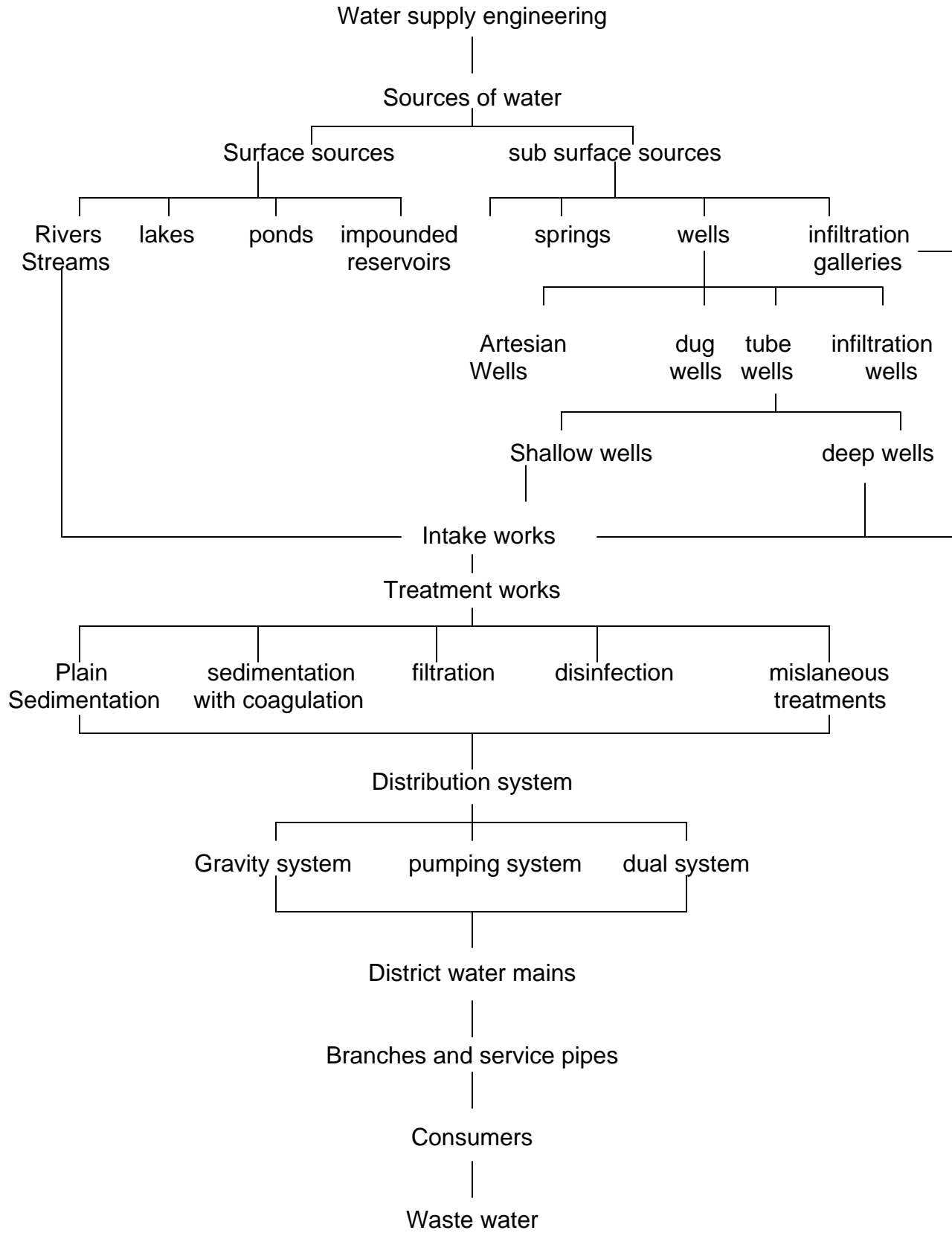

**Fig 1.2**

**SUMMARY:**

1. Nearly 80% of the communicable diseases are transmitted through drinking water. Hence to protect the health of the community, protected water supply should be made available for all
2. The water contains minerals like calcium, magnesium, Iron, Zinc etc in small quantities at requisite levels and free from harmful impurities is called wholesome water. It promote better health and is not injurious in anyway.
3. To achieve the goal of “Health for all by 2000 A.D.” several states, National, international and non-governmental agencies are working to make wholesome water available to all.

**SHORT ANSWER QUESTIONS**

1. What are the uses of water?
2. Define wholesome water.
3. What is ‘potable’ water?
4. Write any two objectives of community water supply system.

**ESSAY TYPE QUESTIONS**

1. Explain the need for protected water supply.
2. What is meant by wholesome water? What are the requirements of wholesome water?

## CHAPTER 2

### WATER DEMANDS

#### 2.1 VARIOUS TYPES OF WATER DEMANDS

While designing the water supply scheme for a town or city, it is necessary to determine the total quantity of a water required for various purposes by the city. As a matter of fact the first duty of the engineer is to determine the water demand of the town and then to find suitable water sources from where the demand can be met. But as there are so many factors involved in demand of water, it is not possible to accurately determine the actual demand. Certain empirical formulae and thumb rules are employed in determining the water demand, which is very near to the actual demand.

Following are the various types of water demands of a city or town:

- i. Domestic water demand
- ii. Industrial demand
- iii. Institution and commercial demand
- iv. Demand for public use
- v. Fire demand
- vi. Losses and wastes

##### 2.1.1 DOMESTIC WATER DEMAND

The quantity of water required in the houses for drinking, bathing, cooking, washing etc is called domestic water demand and mainly depends upon the habits, social status, climatic conditions and customs of the people. As per IS: 1172-1963, under normal conditions, the domestic consumption of water in India is about 135 litres/day/capita. But in developed countries this figure may be 350 litres/day/capita because of use of air coolers, air conditioners, maintenance of lawns, automatic household appliances.

The details of the domestic consumption are

a) Drinking	-----	5 litres
b) Cooking	-----	5 litres
c) Bathing	-----	55 litres
d) Clothes washing	-----	20 litres
e) Utensils washing	-----	10 litres
f) House washing	-----	10 litres
		-----
		135 litres/day/capita

### 2.1.2 INDUSTRIAL DEMAND

The water required in the industries mainly depends on the type of industries, which are existing in the city. The water required by factories, paper mills, Cloth mills, Cotton mills, Breweries, Sugar refineries etc. comes under industrial use. The quantity of water demand for industrial purpose is around 20 to 25% of the total demand of the city.

### 2.1.3 INSTITUTION AND COMMERCIAL DEMAND

Universities, Institution, commercial buildings and commercial centers including office buildings, warehouses, stores, hotels, shopping centers, health centers, schools, temple, cinema houses, railway and bus stations etc comes under this category. As per IS: 1172-1963, water supply requirements for the public buildings other than residences as follows.

Sl.No.	Type of Building	Construction per capita per day (litres)
1.	a) Factories where bathrooms are required to be provided.	45
	b) Factories where no bathrooms are required to be provided	30
2.	Hospitals per bed	
	a) No. of beds not exceeding 100 No.	340
	b) No. of beds exceeding 100 No.	450
3.	Nurses homes and medical quarters.	135
4.	Hostels	135
5.	Offices	45
6.	Restaurants (per seat)	70
7.	Hotel (per bed)	180
8.	Cinema concert halls and theatres (per seat)	15
9.	Schools	
	a) Day schools	45
	b) Boarding schools	135
10.	Garden, sports grounds	35 per sq.m
11.	Animal/vehicles	45

**Table 2.1**



### 2.1.4 DEMAND FOR PUBLIC USE

Quantity of water required for public utility purposes such as for washing and sprinkling on roads, cleaning of sewers, watering of public parks, gardens, public fountains etc comes under public demand. To meet the water demand for public use, provision of 5% of the total consumption is made designing the water works for a city.

The requirements of water for public utility shall be taken as given in Table 2.2

Sl.No.	Purpose	Water Requirements
1.	Public parks	1.4 litres/m <sup>2</sup> /day
2.	Street washing	1.0-1.5 litres/m <sup>2</sup> /day
3.	Sewer cleaning	4.5 litres/head/day

**Table 2.2**

### 2.1.5 FIRE DEMAND

Fire may take place due to faulty electric wires by short circuiting, fire catching materials, explosions, bad intension of criminal people or any other unforeseen mishappenings. If fires are not properly controlled and extinguished in minimum possible time, they lead to serious damage and may burn cities.

All the big cities have full fire-fighting squads. As during the fire breakdown large quantity of water is required for throwing it over the fire to extinguish it, therefore provision is made in the water work to supply sufficient quantity of water or keep as reserve in the water mains for this purpose. In the cities fire hydrants are provided on the water mains at 100 to 150 m apart for fire demand.

The quantity of water required for fire fighting is generally calculated by using different empirical formulae. For Indian conditions kuichings formula gives satisfactory results.

$$Q=3182 \sqrt{p}$$

Where 'Q' is quantity of water required in litres/min

'P' is population of town or city in thousands

### 2.1.6 LOSSES AND WASTES

All the water, which goes in the distribution, pipes does not reach the consumers. The following are the reasons

1. Losses due to defective pipe joints, cracked and broken pipes, faulty valves and fittings.

2. Losses due to, consumers keep open their taps of public taps even when they are not using the water and allow the continuous wastage of water
3. Losses due to unauthorised and illegal connections

While estimating the total quantity of water of a town; allowance of 15% of total quantity of water is made to compensate for losses, thefts and wastage of water

## 2.2 PER CAPITA DEMAND

If 'Q' is the total quantity of water required by various purposes by a town per year and 'p' is population of town, then per capita demand will be

$$\text{Per capita demand} = \frac{Q}{P \times 365} \text{ litres/day}$$

Per capita demand of the town depends on various factors like standard of living, no. and type of commercial places in a town etc. For an average Indian town, the requirement of water in various uses is as under

i.	Domestic purpose	-----	135 litres/c/d
ii.	Industrial use	-----	40 litres/c/d
iii.	Public use	-----	25 litres/c/d
iv.	Fire Demand	-----	15 litres/c/d
v.	Losses, Wastage and thefts	-----	55 litres/c/d
			-----
			Total : 270 litres/capita/day

The total quantity of water required by the town per day shall be 270 multiplied with the total population in litres/day.

## 2.3 FACTORS AFFECTING PER CAPITA DEMAND

The following are the main factors affecting for capita demand of the city or town.

- a) **Climatic conditions** : The quantity of water required in hotter and dry places is more than cold countries because of the use of air coolers, air conditioners, sprinkling of water in lawns, gardens, courtyards, washing of rooms, more washing of clothes and bathing etc. But in very cold countries sometimes the quantity of water required may be more due to wastage, because at such places the people often keep their taps open and water continuously flows for fear of freezing of water in the taps and use of hot water for keeping the rooms warm.
- b) **Size of community** : Water demand is more with increase of size fo town because more water is required in street washing, running of sewers, maintenance of parks and gardens.

- c) **Living standard of the people :** The per capita demand of the town increases with the standard of living of the people because of the use of air conditioners, room coolers, maintenance of lawns, use of flush, latrines and automatic home appliances etc.
- d) **Industrial and commercial activities :** As the quantity of water required in certain industries is much more than domestic demand, their presence in the town will enormously increase per capita demand of the town. As a matter of the fact the water required by the industries has no direct link with the population of the town.
- e) **Pressure in the distribution system:** The rate of water consumption increase in the pressure of the building and even with the required pressure at the farthest point, the consumption of water will automatically increase. This increase in the quantity is firstly due to use of water freely by the people as compared when they get it scarcely and more water loss due to leakage, wastage and thefts etc.
- f) **System of sanitation:** Per capita demand of the towns having water carriage system will be more than the town where this system is not being used.
- g) **Cost of water:** The cost of water directly affects its demand. If the cost of water is more, less quantity of water will be used by the people as compared when the cost is low.

## 2.4 VARIATIONS IN DEMAND

The per capita demand of town is the average consumption of water for a year. In practice it has been seen that this demand doesnot remain uniform throughout the year but it various from season to season, even hour to hour.

### 2.4.1 SEASONAL VARIATIONS

The water demand varies from season to season. In summer the water demand is maximum, because the people will use more water in bathing, cooling, lawn watering and street sprinkling. This demand will becomes minimum in winter because less water will be used in bathing and there will be no lawn watering. The variations may be upto 15% of the average demand of the year.

### 2.4.2 DAILY VARIATIONS

This variation depends on the general habits of people, climatic conditions and character of city as industrial, commercial or residential. More water demand will be on Sundays and holidays due to more comfortable bathing, washing etc as compared to other working days. The maximum daily consumption is usually taken as 180% of the average consumption.

### **2.4.3 HOURLY VARIATIONS**

On Sundays and other holidays the peak hours may be about 8 A.M. due to late awakening where as it may be 6 A.M. to 10 A.M. and 4 P.M. to 8 P.M. and minimum flow may be between 12P.M. to 4P.M. when most of the people are sleeping. But in highly industrial city where both day and night shifts are working, the consumption in night may be more. The maximum consumption may be rise upto 200% that of average daily demand.

The determination of this hourly variations is most necessary, because on its basis the rate of pumping will be adjusted to meet up the demand in all hours.

### **2.5 DESIGN PERIOD**

The complete water supply project includes huge and costly constructions such as dams, reservoirs, treatment works and network of distribution pipelines. These all works cannot be replaced easily or capacities increased conveniently for future expansions.

While designing and constructing these works, they should have sufficient capacity to meet future demand of the town for number of years. The number of years for which the designs of the water works have been done is known as design period. Mostly water works are designed for design period of 22-30 years, which is fairly good period.

### **2.6 TOTAL REQUIREMENT OF WATER FOR A TOWN OR A CITY**

Total quantity of water required by a town or a city per day shall be 270 multiplied with the total population in litres/day.

### **2.7 POPULATION FORECASTING METHODS AND PROBLEMS**

When the design period is fixed the next step is to determine the population of a town or city population of a town depends upon the factors like births, deaths, migration and annexation. The future development of the town mostly depends upon trade expansion, development industries, and surrounding country, discoveries of mines, construction of railway stations etc may produce sharp rises, slow growth, stationary conditions or even decrease the population. For the prediction of population, it is better to study the development of other similar towns, which have developed under the same circumstances, because the development of the predicted town will be more or less on the same lines.

The following are the standard methods by which the forecasting population is done.

- i. Arithmetical increase method
- ii. Geometrical increase method
- iii. Incremental increase method
- iv. Simple graph method

- v. Decrease rate of growth method
- vi. Comparative graph method
- vii. The master plan method

**Problem:** The following data have been noted from the census department.

YEAR	POPULATION
1940	8000
1950	12000
1960	17000
1970	22500

Find the probable population in the year 1980, 1990 and 2000.

### 2.7.1 ARITHMETICAL INCREASE METHOD

This method is based on the assumption that the population is increasing at a constant rate. The rate of change of population with time is constant. The population after 'n' decades can be determined by the formula.

$$P_n = P + n.c \text{ where}$$

P → population at present

n → No. of decades

c → Constant determined by the average  
of increase of 'n' decades

YEAR	POPULATION	INCREASE IN POPULATION
1940	8000	---
1950	12000	4000
1960	17000	5000
1970	22500	5500
	TOTAL	14500
	AVERAGE	4833

**Solution:**

YEAR	POPULATION
1980	$22500 + 1 \times 4833 = 27333$
1990	$22500 + 2 \times 4833 = 32166$
2000	$22500 + 3 \times 4833 = 36999$

### 2.7.2 GEOMETRICAL INCREASE METHOD

This method is based on the assumption that the percentage increase in population from decade to decade remains constant. In this method the average percentage of growth of last few decades is determined, the population forecasting is done on the basis that percentage increase per decade will be the same.

The population at the end of 'n' decades is calculated by

$$P_n = P \left( 1 + \frac{I_G}{100} \right)^n$$

where

P → population at present

C → average percentage of growth of 'n' decades

Year	Population	Increase in population	Percentage increase in population
1940	8000	---	
1950	12000	4000	$\frac{4000}{8000} \times 100 = 50\%$
1960	17000	5000	$\frac{5000}{12000} \times 100 = 41.7\%$
1970	22500	5500	$\frac{5500}{17000} \times 100 = 32.4\%$
	TOTAL	14500	124.1%
	AVERAGE	4833	41.37%

The population at the end of various decades shall be as follows:

YEAR	EXPECTED POPULATION
1980	$22500 + 41.37 / 100 \times 22500 = 31808$
1990	$31800 + 41.37 / 100 \times 31800 = 49935$
2000	$49935 + 41.37 / 100 \times 49395 = 68524$

### 2.7.3 INCREMENTAL INCREASE METHOD

This method is improvement over the above two methods. The average increase in the population is determined by the arithmetical method and to this is added the average of the net incremental increase once for each future decade.

#### Solution:

Year	Population	Increase in population	Incremental increase
1940	8000	---	---
1950	12000	4000	---
1960	17000	5000	+ 1000
1970	22500	5500	+ 1500
	TOTAL	14500	+ 2500
	AVERAGE	4833	1,250

The population at the end of the various decades shall be as follows:

YEAR	EXPECTED POPULATION
1980	$22500 + (4833 + 1250) \times 1 = 28583$
1990	$22500 + (4833 + 1250) \times 2 = 34666$
2000	$22500 + (4833 + 1250) \times 3 = 40749$

## SUMMARY

1. Uses of water is classified as
  - a) Domestic demand
  - b) Industrial demand
  - c) Fire fighting demand
  - d) Demand for public use
  - e) Institution and commercial demand
  - f) Losses and wastes
2. Average per capita demand is the average of total quantity supplied in a year per day per a town divided by the total population
3. Per capita demand for urban area is 135 lpcd and rural area is 70 lpcd (Litres per capita per day)
4. Variation of demand are
  - a) Seasonal variation – 1.3 times the yearly average demand
  - b) Daily variation – 1.8 times the average demand
  - c) Hourly variation – 1.5 times the average demand
5. Factors that effect per capita demand are
  - a) Climate
  - b) Population
  - c) Standard of living
  - d) Pressure in the system
  - e) System of sanitation
  - f) System of supply
  - g) Cost of water
6. Design period is the period the demand at the end of which period is considered for the design of the system. Design period of
  - a) Distribution system – 30 years
  - b) Treatment units , pumps, service reservoirs – 15 years
  - c) Impounding reservoir and dam – 50 years
7. Population at the end of design period is forecasted by
  - a) Arthematical increase method  $P_n = P_0 + n \times a$
  - b) Geometrical increase method  $P_n = P_0 ( 1 + r )^n$ .
  - c) Incremental increase method  $P_n = P_0 + n . a + n ( n+1 ).b / 2$ .
  - d) Graphical method



## QUESTIONS

### 2 MARKS QUESTIONS (SHORT ANSWER QUESTIONS)

1. Mention the types of water demand.
2. What are the domestic needs of water?
3. What is the formula used for the firefighting demand?
4. Mention the reasons for losses and wastage of water.
5. What is meant by PER CAPITA DEMAND?
6. Name the different types of seasonal variations.
7. Name the different methods of forecasting methods of population.
8. Name the factors affecting for increase or decrease of population.

### 6 MARKS QUESTIONS (ESSAY TYPE ANSWER QUESTIONS)

1. Explain the various types of water demands.
2. Explain the various factors affecting the per capita demand.
3. Explain any two methods of forecasting the population of town.
4. Population of a town as obtained from the census report is as follows.

YEAR	1941	1951	1961	1971
Population (in thousands)	242	485	770	1090

Estimate the population of the town in the year 1981, 1991 & 2001 by

1. Arithmetic increase method
2. Geometrical increase method
3. Incremental increase method

**CHAPTER 3**  
**SOURCES OF WATER SUPPLY**

**GENERAL INTRODUCTION**

Water is the most abundant compound in nature. It covers 75% of the earth surface. About 97.3% of water is contained in the great oceans that are saline and 2.14% is held in icecaps glaciers in the poles, which are also not useful. Barely the remaining 0.56% found on earth is in useful form for general livelihood. Total quantity of water available on the planet “EARTH” in various states and religions are given in the table 3.1

LOCATION	VOLUME (m <sup>3</sup> )	% OF TOTAL
<u>Land Areas</u>		
Fresh water lakes	152 x 10 <sup>12</sup>	0.009
Saline lakes	104 x 10 <sup>12</sup>	0.008
Inland seas, Rivers	1.25 x 10 <sup>12</sup>	0.001
Soil moisture	67 x 10 <sup>12</sup>	0.005
Ground water	8350 x 10 <sup>12</sup>	0.005
Icecaps and glaciers	52 x 10 <sup>12</sup>	0.610
TOTAL	37,800 x 10 <sup>12</sup>	2.80
<u>Atmosphere</u>		
Water vapour (clouds)	13 x 10 <sup>12</sup>	0.001
<u>Oceans</u>		
Water in the oceans	13,20,000 x 10 <sup>12</sup>	97.3
TOTAL ON PLANET	13,60,000 x 10 <sup>12</sup>	100

**Table 3.1 WATER ON THE PLANET**

**3.1 HYDROLOGICAL CONCEPTS**

Hydrology is the science, which deals with the increment of the water on the ground, under the ground, evaporation from the land and water surface and transportation from the vegetation and going back into atmosphere where it precipitates.

**3.1.1. DEFINITION**

The water which goes in atmosphere by evaporation and transpiration again comes back in the form of precipitation under favourable climatic conditions is known as hydrological cycle of water.

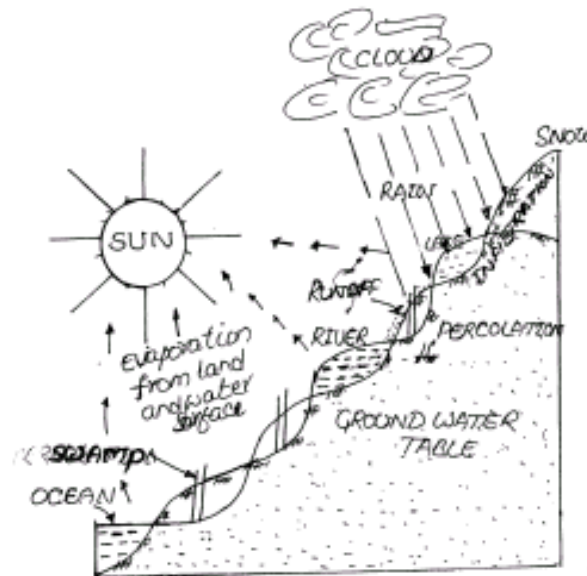

**Fig 3.1 Hydrological cycle**

Fig 3.1 illustrates the hydrological cycle of water. Due to sun's heat water from the earth's surfaces, lakes, rivers, seas etc evaporates and rises upwards. At high altitude due to reduction in the atmosphere pressure these water vapours expand by absorbing energy from the surrounding air, which cools down. When it falls below the dew point it cannot retain the excessive moisture, which starts falling in the form of rain, hails, dew, sleet, frost or precipitation. Various factors such as temperature, atmospheric pressure, velocity of wind, height of mountains in the region, presence of forests, position of land and water areas etc and their complex relation are responsible for the precipitation. This precipitation and evaporation processes continue forever and balance is maintained between the two by nature.

### 3.1.2 PRECIPITATION

The evaporated water from the surfaces of streams, rivers, sea, ponds, wet surfaces, trees and plants etc again returned to the earth surface by the condensation in the form of rain, hails, dew, sleet etc is known as precipitation. The major part of the precipitation occurs in the form of rain and other forms quantities are very small. The water of precipitation further goes off in the following ways.

- i. **RUN-OFF:** After precipitation a portion of its water flows over the ground in the form of rivers and streams and some water flows towards lakes and ponds and collected there.
- ii. **INFILTRATION:** A portion of precipitation, percolates in the ground and it is stored in the form of sub-soil or ground water.
- iii. **EVAPORATION:** some portion of the precipitation is also evaporated from the lakes, rivers, reservoirs and wet surfaces in the form of vapour due to sun's heat is known as evaporation

- iv. **EVAPOTRANSPIRATION:** The roots of the trees suck water from the ground and some portion of it evaporates in the atmosphere through leaves in the form of transpiration.

### **3.2 SURFACE SOURCES**

All the sources of water can be broadly divided into

- 1. Surface sources and
- 2. Sub surface sources

The surface sources further divided into

- i. Streams
- ii. Rivers
- iii. Ponds
- iv. Lakes
- v. Impounding reservoirs etc.

#### **3.2.1 NATURAL PONDS AND LAKES**

In mountains at some places natural basins are formed with impervious bed by springs and streams are known as “lakes”. The quality of water in the natural ponds and lakes depends upon the basin’s capacity, catchment area, annual rainfall, porosity of ground etc. But lakes and ponds situated at higher altitudes contain almost pure water which can be used without any treatment. But ponds formed due to construction of houses, road, railways contain large amount of impurities and therefore cannot be used for water supply purposes.

#### **3.2.2 STREAMS AND RIVERS**

Rivers and streams are the main source of surface source of water. In summer the quality of river water is better than monsoon because in rainy season the run-off water also carries with clay, sand, silt etc which make the water turbid. So river and stream water require special treatments. Some rivers are snowfed and perennial and have water throughout the year and therefore they do not require any arrangements to hold the water. But some rivers dry up wholly or partially in summer. So they require special arrangements to meet the water demand during hot weather. Mostly all the cities are situated near the rivers discharge their used water of sewage in the rivers, therefore much care should be taken while drawing water from the river.

#### **3.2.3 IMPOUNDING RESERVOIRS**

In some rivers the flow becomes very small and cannot meet the requirements of hot weather. In such cases, the water can be stored by constructing a bund, a weir or a dam across the river at such places where minimum area of land is submerged in the water and max. quantity of water to be stored. In lakes and reservoirs, suspended impurities settle down in the bottom, but in their beds algae, weeds, vegetable and organic growth takes place which produce bad smell, taste and colour in water. Therefore

this water should be used after purification. When water is stored for long time in reservoirs it should be aerated and chlorinated to kill the microscopic organisms which are born in water.

### 3.3 SUBSURFACE SOURCES

These are further divided into

- (i) Infiltration galleries
- (ii) Infiltration wells
- (iii) Springs etc

#### 3.3.1 INFILTRATION GALLERIES

A horizontal nearly horizontal tunnel which is constructed through water bearing strata for tapping underground water near rivers, lakes or streams are called "Infiltration galleries". The yield from the galleries may be as much as  $1.5 \times 10^4$  lit/day/metre length of infiltration gallery. For maximum yield the galleries may be placed at full depth of the aquifer. Infiltration galleries may be constructed with masonry or concrete with weep holes of 5cm x 10cm.

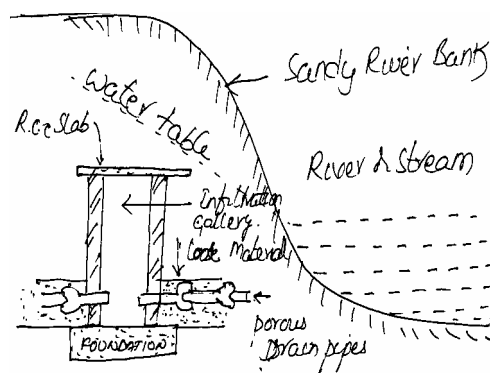

**Fig 3.2 Infiltration Gallery**

#### 3.3.2 INFILTRATION WELLS

In order to obtain large quantity of water, the infiltration wells are sunk in series in the banks of river. The wells are closed at top and open at bottom. They are constructed by brick masonry with open joints as shown in fig. 3.3

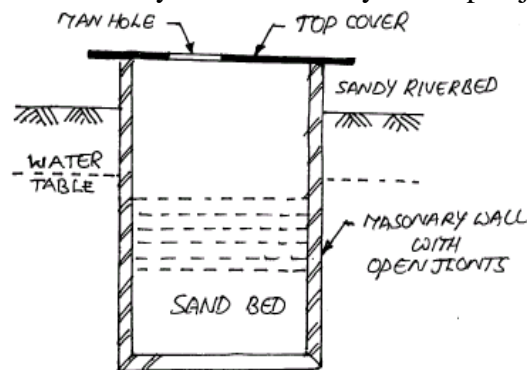

**Fig 3.3 Infiltration Well**

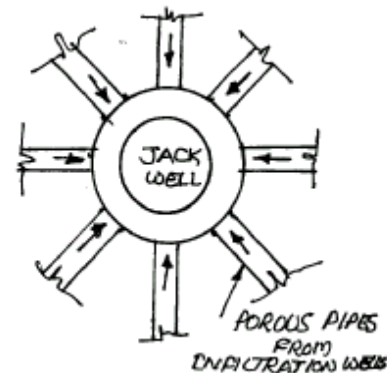

**Fig 3.4 Jack Well**

For the purpose of inspection of well, the manholes are provided in the top cover. The water filtrates through the bottom of such wells and as it has to pass through sand bed, it gets purified to some extent. The infiltration well inturn are connected by porous

pipes to collecting sump called jackwell and there water is pumped to purification plant for treatment.

### 3.3.3 SPRINGS:

Sometimes ground water reappears at the ground surface in the form of springs. Springs generally supply small quantity of water and hence suitable for the hill towns. Some springs discharge hot water due to presence of sulphur and useful only for the cure of certain skin disease patients.

#### Types of springs:

1. **Gravity Springs:** When the surface of the earth drops sharply the water bearing stratum is exposed to atmosphere and gravity springs are formed as shown in fig.3.5

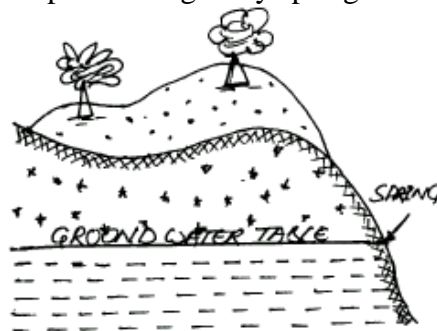

**Fig 3.5 Gravity Spring**

2. **Surface Spring:** This is formed when an impervious stratum which is supporting the ground water reservoir becomes out crops as shown in fig.3.6

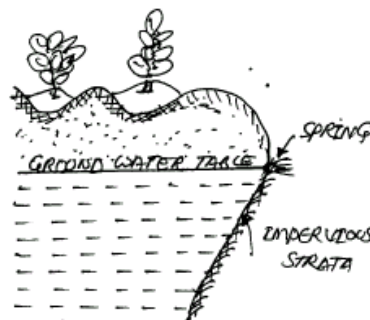

**Fig 3.6 Surface Spring**

3. **Artesian Spring:** When the ground water rises through a fissure in the upper impervious stratum as shown in fig.3.7

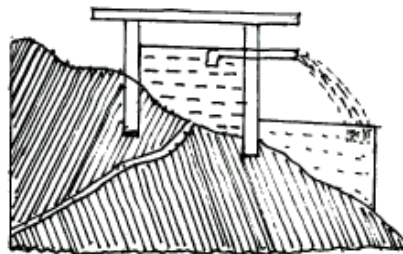

**Fig 3.7 Artesian Spring**

When the water-bearing stratum has too much hydraulic gradient and is closed between two imperious stratum, the formation of Artesian spring from deep seated spring

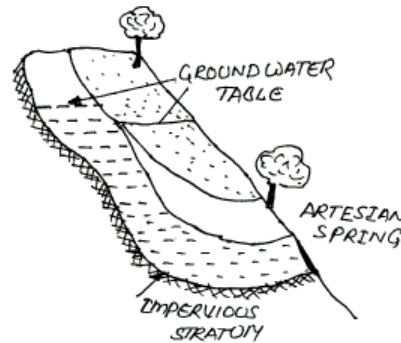

**Fig 3.8 Artesian Spring**

### 3.3.4. WELLS:

A well is defined as an artificial hole or pit made in the ground for the purpose of tapping water. In India 75 to 85% of Indian population has to depend on wells for its water supply.

The three factors which form the basis of theory of wells are

1. Geological conditions of the earth's surface
2. Porosity of various layers
3. Quantity of water, which is absorbed and stored in different layers.

The following are different types of wells

1. Shallow wells
2. Deep wells
3. Tube wells
4. Artesian wells

#### 3.3.4 (a) Shallow Wells :

Shallow wells are constructed in the uppermost layer of the earth's surface. The diameter of well varies from 2 to 6 m and a maximum depth of 7m. Shallow wells may be lined or unlined from inside. Fig. 3.9 shows a shallow well with lining (steining). These wells are also called draw wells or gravity wells or open wells or drag wells or percolation wells.

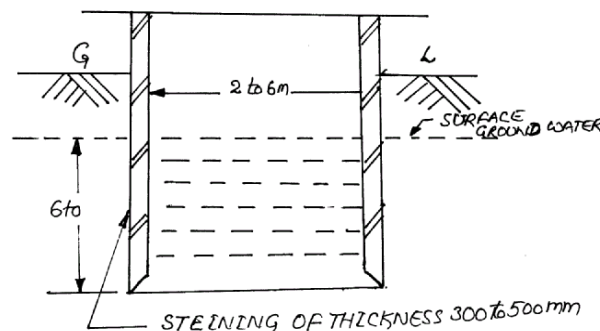

**Fig 3.9 Shallow Well**

Quantity of water available from shallow wells is limited as their source of supply is uppermost layer of earth only and sometimes may even dry up in summer. Hence they are not suitable for public water supply schemes. The quantity of water obtained from shallow wells is better than the river water but requires purification. The shallow wells should be constructed away from septic tanks, soak pits etc because of the contamination of effluent.

The shallow wells are used as the source of water supply for small villages, undeveloped municipal towns, isolated buildings etc because of limited supply and bad quality of water.

### 3.3.4 (b) Deep Wells :

The Deep wells obtain their quota of water from an aquifer below the impervious layer as shown in fig No. The theory of deep well is based on the travel of water from the outcrop to the site of deep well. The outcrop is the place where aquifer is exposed to the atmosphere. The rain water entered at outcrop and gets thoroughly purified when it reaches to the site of deep well. But it dissolves certain salts and therefore become hard. In such cases, some treatment would be necessary to remove the hardness of water.

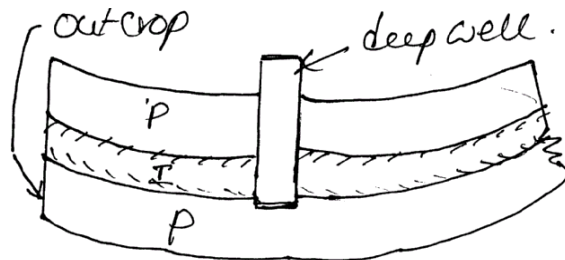

**Fig 3.10 Deep Well**

The depth of deep well should be decided in such a way that the location of outcrop is not very near to the site of well. The water available at a pressure greater atmospheric pressure, therefore deep wells are also referred to as a pressure wells.

### 3.4 INTAKES FOR COLLECTING SURFACE WATER:

The main function of the intakes works is to collect water from the surface source and then discharge water so collected, by means of pumps or directly to the treatment water.

Intakes are structures which essentially consists of opening, grating or strainer through which the raw water from river, canal or reservoir enters and carried to the sump well by means of conducts water from the sump well is pumped through the rising mains to the treatment plant.

The following points should be kept in mind while selecting a site for intake works.



1. Where the best quality of water available so that water is purified economically in less time.
2. At site there should not be heavy current of water, which may damage the intake structure.
3. The intake can draw sufficient quantity of water even in the worst condition, when the discharge of the source is minimum.
4. The site of the work should be easily approachable without any obstruction
5. The site should not be located in navigation channels
6. As per as possible the intake should be near the treatment plant so that conveyance cost is reduced from source to the water works
7. As per as possible the intake should not be located in the vicinity of the point of sewage disposal for avoiding the pollution of water.
8. At the site sufficient quantity should be available for the future expansion of the water-works.

### Types of Intake structures:

Depending upon the source of water the intake works are classified as following

1. Lake Intake
2. Reservoir Intake
3. River Intake
4. Canal Intake

#### 1. LAKE INTAKE:

For obtaining water from lakes mostly submersible intakes are used. These intakes are constructed in the bed of the lake below the water level; so as to draw water in dry season also. These intakes have so many advantages such as no obstruction to the navigation, no danger from the floating bodies and no trouble due to ice. As these intakes draw small quantity of water, these are not used in big water supply schemes or on rivers or reservoirs. The main reason being that they are not easily approachable for maintenance.

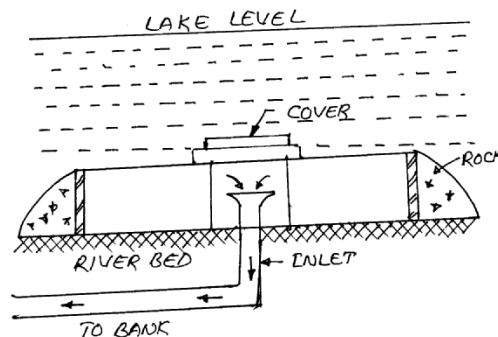

**Fig 3.11 Lake Intake**

## 2. RIVER INTAKE:

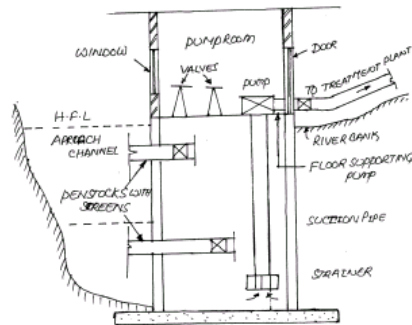
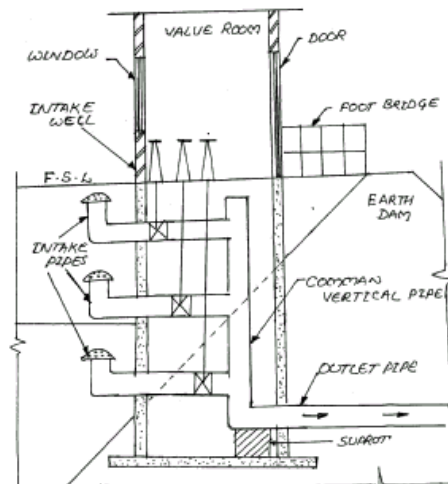

**Fig. 3.12 River Intake**

Water from the rivers is always drawn from the upstream side, because it is free from the contamination caused by the disposal of sewage in it. It is circular masonry tower of 4 to 7 m in diameter constructed along the bank of the river at such place from where required quantity of water can be obtained even in the dry period. The water enters in the lower portion of the intake known as sump well from penstocks.

## 3. RESERVOIR INTAKE:

Fig 3.13 shows the details of reservoir intake. It consists of an intake well, which is placed near the dam and connected to the top of dam by foot bridge.



**Fig. 3.13 Reservoir Intake**

The intake pipes are located at different levels with common vertical pipe. The valves of intake pipes are operated from the top and they are installed in a valve room. Each intake pipe is provided with bell mouth entry with perforations of fine screen on its surface. The outlet pipe is taken out through the body of dam. The outlet pipe should be suitably supported. The location of intake pipes at different levels ensures supply of water from a level lower than the surface level of water.

When the valve of an intake pipe is opened the water is drawn off from the reservoir to the outlet pipe through the common vertical pipe. To reach upto the bottom of intake from the floor of valve room, the steps should be provided in Zigzag manner.

#### 4. CANAL INTAKE:

Fig 3.14 shows the details of canal intake. A intake chamber is constructed in the canal section. This results in the reduction of water way which increases the velocity of flow. It therefore becomes necessary to provide pitching on the downstream and upstream portion of canal intake.

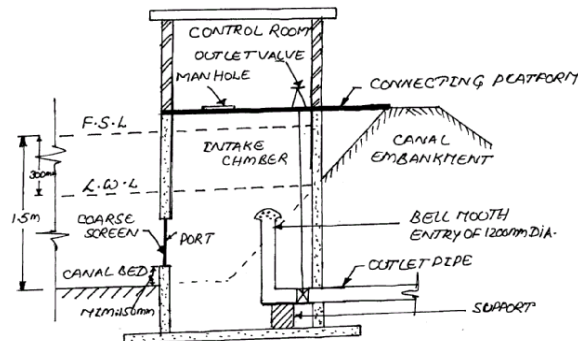

**Fig. 3.14 Canal Intake**

The entry of water in the intake chamber takes through coarse screen and the top of outlet pipe is provided with fine screen. The inlet to outlet pipe is of bell-mouth shape with perforations of the fine screen on its surface. The outlet valve is operated from the top and it controls the entry of water into the outlet pipe from where it is taken to the treatment plant.

#### SUMMARY

1. Sources of water supply are classified as
  - a) Surface sources
  - b) Sub surface sources
2. Surface sources include rainfall, lakes, ponds, rivers and reservoirs etc.
3. Subsurface sources are wells, springs, infiltration galleries
4. Surface water is withdrawn by constructing intake structure
5. Intake structures are classified as
  - a) Lake intake
  - b) Reservoir intake
  - c) River intake
  - d) Canal intake

6. Wells are classified as
  - a) Shallow wells
  - b) Deep wells
7. Deep wells get their supply from more than one water bearing stratum
8. Infiltration galleries are constructed below the river bed to draw water during non monsoon season.

### **SHORT ANSWER QUESTIONS**

1. what is hydrological cycle?
2. List the sources of water supply.
3. Mention different types of intakes.
4. What is shallow well?
5. What is infiltration gallery?
6. Define spring.
7. What are the different types of springs?
8. Name the types of wells.
9. Define deep well.
10. What is precipitation?
11. What is the purpose of intake structure?

### **ESSAY TYPE QUESTIONS**

1. Explain the sources of water.
2. Explain the classification of wells.
3. What are points should be kept in mind while selecting a site for intake structure?
4. Explain any one of intake structure with neat sketch.

## CHAPTER 4

### QUALITY OF WATER

#### 4.0 GENERAL INTRODUCTION

Absolutely pure water is never found in nature and contains number of impurities in varying amounts. The rainwater which is originally pure, also absorbs various gases, dust and other impurities while falling. This water when moves on the ground further carries salt, organic and inorganic impurities. So this water before supplying to the public should be treated and purified for the safety of public health, economy and protection of various industrial process, it is most essential for the water work engineer to thoroughly check analyse and do the treatment of the raw water obtained the sources, before its distribution. The water supplied to the public should be strictly according to the standards laid down from time to time.

#### 4.1 CHARACTERISTICS OF WATER

For the purpose of classification, the impurities present in water may be divided into the following three categories.

##### 4.2.1 PHYSICAL CHARACTERISTICS

The following are the physical characteristics

1. Turbidity
2. Colour and temperature
3. Taste and odour

##### 4.2.1.1 TURBIDITY

Turbidity is caused due to presence of suspended and colloidal matter in the water. The character and amount of turbidity depends upon the type of soil over which the water has moved ground waters are less turbid than the surface water.

Turbidity is a measure of resistance of water to the passage of light through it. Turbidity is expressed as NTU (Nephelometric Turbidity Units) or PPM (parts per million) or Milligrams per litre (mg/l). Turbidity is measured by

- 1) Turbidity rod or Tape 2) Jacksons Turbidimeter 3) Bal's Turbidimeter

The Sample to be tested is poured into a test tube and placed in the meter and units of turbidity is read directly on the scale by a needle or by digital display.

Drinking water should not have turbidity more than 10 N.T.U. This test is useful in determining the detention time in settling for raw water and to dosage of coagulants required to remove turbidity.

#### **4.2.1.2. COLOUR AND TEMPERATURE**

Colour in water is usually due to organic matter in colloidal condition but some times it is also due to mineral and dissolved organic impurities. The colour produced by one milligram of platinum in a litre of water has been fixed as the unit of colour. The permissible colour for domestic water is 20ppm on platinum cobalt scale. The colour in water is not harmful but objectionable.

Temperature of water is measured by means of ordinary thermometers. The temperature of surface water is generally at atmospheric temperature, while that of ground water may be more or less than atmospheric temperature. The most desirable temperature for public supply between 4.4°C to 10°C. The temperature above 35°C are unfit for public supply, because it is not palatable.

#### **4.2.1.3 TASTE AND ODOUR**

Taste and odour in water may be due to presence of dead or live micro-organisms, dissolved gases such as hydrogen sulphide, methane, carbon dioxide or oxygen combined with organic matter, mineral substances such as sodium chloride, iron compounds and carbonates and sulphates of other substances. The tests of these are done by sense of smell and taste because these are present in such small proportions that it is difficult to detect them by chemical analysis. The water having bad smell and odour is objectionable and should not be supplied to the public.

The intensities of the odours are measured in terms of threshold number. This number is numerically equal to the amount of sample of water in C.C's required to be added to one litre of fresh odourless water.

#### **4.2.2. CHEMICAL CHARACTERISTICS**

In the chemical analysis of water, these tests are done that will reveal the sanitary quality of the water. Chemical tests involve the determination of total solids, PH value, Hardness of water, Chloride content etc.

##### **4.2.2.1 TOTAL SOLIDS AND SUSPENDED SOLIDS**

Total solids includes the solids in suspension colloidal and in dissolved form. The quantity of suspended solids is determined by filtering the sample of water through fine filter, drying and weighing. The quantity of dissolved and colloidal solids is determined by evaporating the filtered water obtained from the suspended solid test and weighing the residue. The total solids in a water sample can be directly determined by evaporating the filtered water obtained from the suspended solid test and weighing the residue. The total solids in a water sample can be directly determined by evaporating the water and weighing the residue of the residue of total solids is fused in a muffle furnace the organic solids will decompose where as only inorganic solids will remain. By weighing we can

determine the inorganic solids and deducting it from the total solids, we can calculate organic solids.

#### 4.2.2.2 PH VALUE OF WATER

PH value denotes the concentration of hydrogen ions in the water and it is a measure of acidity or alkalinity of a substance.

$$PH = -\log_{10}[H^+] \text{ or } 14 - \log_{10}[H^+]$$

0	1	2	3	4	5	6	7	8	9	10	11	12	13	14
				Acidity		←	Neutral	→					Alkalinity	

Depending upon the nature of dissolved salts and minerals, the PH value ranges from 0 to 14. For pure water, PH value is 7 and 0 to 7 acidic and 7 to 14 alkaline range. For public water supply PH value may be 6.5 to 8.5. The lower value may cause tuberculation and corrosion, where as high value may produce incrustation, sediment deposits and other bad effects.

PH value of water is generally determined by PH papers or by using PH meter. PH can read directly on scale or by digital display using PH meter.

#### 4.2.2.3 HARDNESS OF WATER

It is a property of water, which prevents the lathering of the soap. Hardness is of two types.

1. Temporary hardness: It is caused due to the presence of carbonates and sulphates of calcium and magnesium. It is removed by boiling.
2. Permanent hardness: It is caused due to the presence of chlorides and nitrates of calcium and magnesium. It is removed by zeolite method.

Hardness is usually expressed in gm/litre or p.p.m. of calcium carbonate in water. Hardness of water is determined by EDTA method. For potable water hardness ranges from 5 to 8 degrees.

#### HARDNESS REMOVABLE

Generally a hardness of 100 to 150 mg/litre is desirable. Excess of hardness leads to the following effects.

1. Large soap consumption in washing and bathing
2. Fabrics when washed become rough and strained with precipitates.
3. Hard water is not fit for industrial use like textiles, paper making, dye and ice cream manufactures.
4. The precipitates clog the pores on the skin and makes the skin rough

5. Precipitates can choke pipe lines and valves
6. It forms scales in the boilers tubes and reduces their efficiency and cause in eruptions
7. Very hard water is not palatable

When softening is practiced when hardness exceeds 300mg/lit. Water hardness more than 600 mg/lit has to be rejected for drinking purpose.

### METHODS OF REMOVAL OF HARDNESS

1. Boiling
2. Freezing
3. Lime addition
4. Lime soda process
5. Excess Lime treatment
6. Caustic soda process
7. Zeolite process
8. Demineralisation or exchange process.

Methods 1,2 and 3 are suitable for removal of temporary hardness and 4 to 8 for both temporary and permanent hardness. The temporary hardness is removed as follows.

#### Boiling

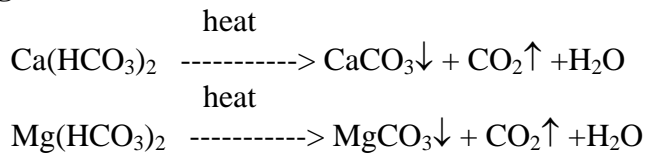

#### Addition of lime

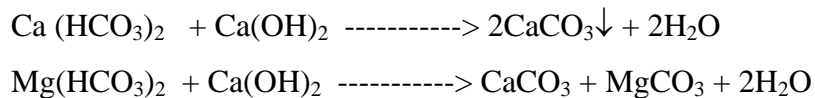

#### Removal of permanent Hardness:

1. **Lime soda process** : In this method, the lime and is sodium carbonate or soda ash are used to remove permanent hardness from water. The chemical reactions involved in this process are as follows.

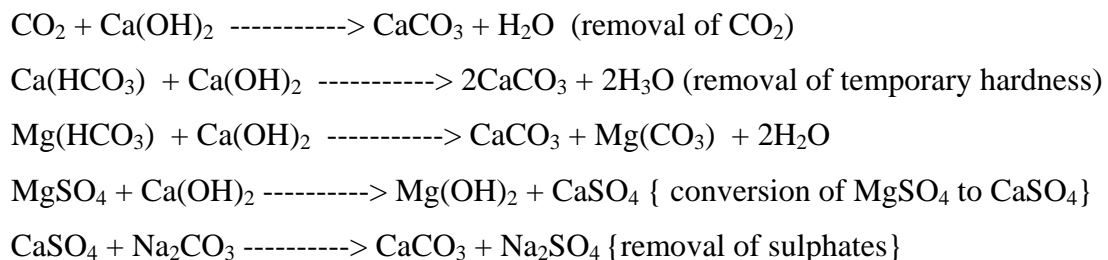



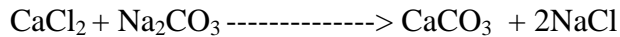
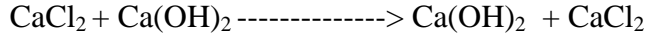

### Advantages of lime soda process

1. The PH value of water treated by this process bring down to 9 and which results in decrease in corrosion of the distribution system.
2. Less quantity of coagulant will be required, if this process is adopted
3. Removal of iron and manganese to some extent
4. Reduction of total mineral content of water
5. Hardness of water is reduced to 40mg/lit (of CaCO<sub>3</sub>) and magnesium upto 10mg/lit
6. The process is economical
7. This process is most suitable for tubed and acidic waters where it will not possible to adopt zeolite process.

### Disadvantages

1. Large quantity of sludge formed during this process to be disposed off by some suitable method
2. This process requires skilled supervision for its successful working
3. If recarbonation is omitted, a thick layer of calcium carbonate will be deposited in the filtering media, distribution pipes etc.

### Zeolite process

This is also known as the base-exchange or Ion exchange process. The hardness may be completely removed by this process.

### Principle

Zeolites are compounds (silicates of aluminium and sodium) which replace sodium Ions with calcium and magnesium Ions when hardwater is passes through a bed of zeolites. The zeolite can be regenerated by passing a concentrated solution of sodium chloride through the bed. The chemical reactions involved are

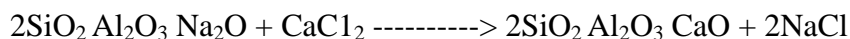
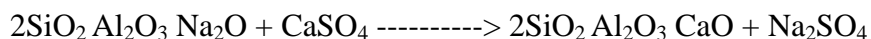
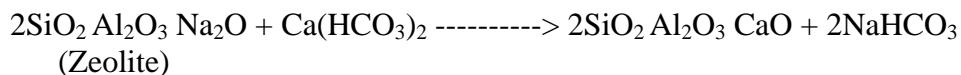

### Regeneration

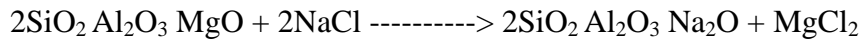
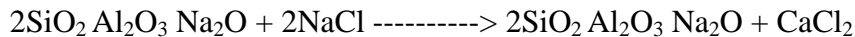

### Advantages

1. In this process, the sludge is not formed hence problem of sludge disposal does not arise
2. It can be operated easily and no skilled supervision required
3. The hardness of water reduces to zero and hence used for boiler and textile industries
4. The process is economical where salt is cheaply available
5. The load on Zeolite can be reduced by combining it with lime or aeration process

### Disadvantages

1. The Zeolite process cannot be used for turbid or acidic water
2. The Zeolite process is unsuitable for water containing Iron and Manganese
3. The Zeolite should be operated carefully to avoid injury or damage to the equipment

### Demineralisation

Both cations and anions are removed by resins similar to zeolites in two columns by ion exchange method. Resins may be regenerated with sulphuric acid and sodium carbonate. This process is used in industries to get distilled water or quality water. The natural motion of water through the atmosphere, earth, plants, trees, rivers and oceans in a cyclic motion through liquid, solid and gaseous phases is called HYDROLOGICAL CYCLE.

#### 4.2.2.4 CHLORIDE CONTENT

The natural waters near the mines and sea dissolve sodium chloride and also presence of chlorides may be due to mixing of saline water and sewage in the water. Excess of chlorides is dangerous and unfit for use. The chlorides can be reduced by diluting the water. Chlorides above 250p.p.m. are not permissible in water.

#### 4.2.2.5. NITROGEN CONTENT

The presence of nitrogen in the water indicates the presence of organic matters in the water. The nitrogen may be present in the water may be in one or more of the following forms.

1. Nitrates
2. Nitrites
3. Free ammonia
4. Albuminoid nitrogen.

Excess presence of nitrogen will cause "METHEMOGLOBINEMIA" disease to the children.

#### **4.2.2.6. METALS AND OTHER CHEMICAL SUBSTANCES**

Water contains various minerals or metal substances such as iron, manganese, copper, lead, barium, cadmium, selenium, fluoride, arsenic etc.

The concentration of iron and manganese should not allow more than 0.3 ppm . Excess will cause discolouration of clothes during washing and incrustation in water mains due to deposition of ferric hydroxide and manganese oxide. Lead and berium are very toxic, low p.p.m of these are allowed. Arsenic, Selenium are poisonous and may cause totally, therefore they must be removed totally. Human beings are effected by presence of high quality of copper in the water. Fewer cavities in the teeth will be formed due to excessive presence of fluoride in water more than 1 p.p.m. A laxative effect is caused in the human body due to excessive presence of sulphate in the water.

#### **4.2.2.7. DISSOLVED GASES**

oxygen and carbondi-oxide are the gases mostly found in the natural water. The surface water contain large amount of dissolved oxygen because they absorb it from the atmosphere. Algae and other tiny plant life of water also give oxygen to the water. The presence of oxygen in the water in dissolved form keep it fresh and sparkling. But more quantity of oxygen causes corrosion to the pipes material.

Water absorbs carbon-dioxide from the atmosphere. If water comes across calcium and magnesium salts, carbon-dioxide reacts with the salts and converts them into bicarbonates, causes hardness in the water. The presence of carbon-dioxide is easily determined by adding lime solution to water gives milky white colour.

#### **4.2.2.8. BIO-CHEMICAL OXYGEN DEMAND**

If the water is contaminated with sewage, the demand of oxygen by organic matter in sewage is known as biochemical oxygen demand. The aerobic action continues till the oxygen is present in sewege. As the oxygen exhausts the anerobic action begins due to which foul smell starts coming. Therefore indirectly the decomposable matters require oxygen, which is used by the organisms.

The aerobic decomposition of organic matters is done in two stages. The carbonaceous matters are first oxidized and the oxidation of nitrogeneous matters takes place in the latter stage.

#### **4.2.3. BACTERIAL AND MICROSCOPICAL CHARACTERISTICS**

The examination of water for the presence of bacteria is important for the water supply engineer from the viewpoint of public health. The bacteria may be harmless to mankind or harmful to mankind. The former category is known as non-pathogenic bacteria and the later category is known as pathogenic bacteria. Many of the bacteria

found in water are derived from air, soil and vegetation. Some of these are able to multiply and continue their existence while the remaining die out in due course of time. The selective medium that promote the growth of particular bacteria and inbuilt the growth of other organisms is used in the lab to detect the presence of the required bacteria, usually coliform bacteria. For bacteriological analysis the following tests are done.

**(a) PLANT COUNT TEST**

In this method total number of bacteria presents in a millitre of water is counted. 1 ml of sample water is diluted in 99ml of sterilized water and 1ml of dilute water is mixed with 10ml of agar of gelatine. This mixture is then kept in incubator at 37°C for 24 hours or 20°C for 48 hours. After the sample will be taken out from the incubator and colonies of bacteria are counted by means of microscope.

Drinking water should not have more than 10 coliforms/100ml.

**(b) M.P.N. TEST (MOST PROBABLE NUMBER)**

The detection of bacteria by mixing different dilutions of a sample of water with fructose broth and keeping it in the incubator at 37°C for 48hours. The presence of acid or carbon-dioxide gas in the test tube will indicate the presence of B-coli. After this the standard statistical tables (Maccardy's) are reffered and the "MOST PROBABLE NUMBER" (MPN) of B-coli per 100ml of water are determined.

For drinking water, the M.P.N. should not be more than 2.

**4.2 WATER BORNE DISEASES**

World health organization has observes that 80% of communicable diseases that are transmitted through water. The diseases like cholera, gastroenteritis, typhoid, amoebia, diarrhoea, polio, hepatitis (Jaundice), Leptospirosis, Dracontiasis are caused by bacteria.

Excess of fluorides present in water [ above 1.5 mg/litre] cause diseases like dental flurosis, sketetal flurosis. This is a permanent irrisible disease that weakens the bone structure. The patient becomes immobile and bedridden.

Excess of nitrates in water causes Mathaemoglobinaemia or blue baby symptoms in infants. It effects the hemoglobin in the blood and reduces its capacity to transport oxygen to the cells. Nitrates in water are caused by industrial effluents, agricultural runoff. Toxic ions of chromium, lead, arsenic and pesticides in water cause diseases affecting the kidney, liver and high blood pressure, paralysis, cancer etc. These toxic substances are due to industrial effluents reaching the surface and ground water sources.

### 4.3 DRINKING WATER STANDARDS

S.No.	CHARACTERISTICS	NORMALLY ACCEPTABLE VALUE	MAX. PERMISSIBLE LIMIT
1.	Temperature	10°C – 15°C	-
2.	Turbidity (N.T.U)	2.5	10
3.	Colour (platinum cobalt scale)	5.0	25
4.	Taste and odour	Unobjectionable	
5.	PH	7.0-8.5	6.5-9.2
6.	Total dissolved solids(mg/litre)	500	1500
7.	Total hardness mg/l (as $\text{CaCO}_3$ )	200	600
8.	Chlorides (as Cl) mg/l	200	1000
9.	Sulphates (as $\text{SO}_4$ ) mg/l	200	400
10.	Nitrates ( as $\text{NO}_3$ ) mg/l	45	45
11.	Fluorides (as F) mg/l	1.0	1.5
12.	Calcium (as Ca) mg/l	75	200
13.	Magnesium (as mg) mg/l	30-120	150
14.	Iron (as Fe) mg/l	0.1	1.0
15.	Manganese (As Mn) mg/l	0.05	0.5
16.	Phenolic compounds (as phenol) mg/l	0.001	0.002
17.	Arsenic (as mg) mg/l	0.05	0.05
18.	Chromium (as $\text{Cr}^{+6}$ ) mg/l	0.05	0.05
19.	Cyanamides (as CN) mg/l	0.05	0.05
20.	Coliform count per 100ml of water sample	Zero	-

### SHORT ANSWER QUESTIONS

1. Name the different characteristics of water.
2. What are the physical characteristics of water?
3. What is the unit for the measurement of turbidity?
4. Define hardness of water.
5. What is temporary hardness of water?
6. What is permanent hardness of water?
7. Name any four chemical characteristics of water.
8. Define PH.
9. What are effects of excess nitrogen content?
10. What are the metals present in water?
11. Name the dissolved gases in the water.
12. Define B.O.D.
13. Name the tests to be conducted for bacteriological tests.
14. Name any four water borne diseases.
15. What is the effect of excess fluoride in water?
16. State any four parameters of drinking water quality standard.
17. What is the range of PH value of domestic water supply?

### ESSAY TYPE QUESTIONS

1. Explain different characteristics of water.
2. What is the turbidity? How it is measured?
3. Define PH of water. Explain the significance of PH.
4. What is significance of biological tests? Explain M.P.N. test?
5. List out the different water borne diseases explain the effects of excess fluoride & nitrogen contents.
6. How total solids is determined?
7. List out the drinking water standards.

## CHAPTER 5

### TREATMENT OF WATER

#### 5.1 GENERAL INTRODUCTION

Water available in various sources contains various types of impurities and cannot be directly used by the public for various purposes, before removing the impurities. For potability water should be free from unpleasant tastes, odours and must have sparkling appearance. The water must be free from disease-spreading germs. The amount and type of treatment process will depend on the quality of raw water and the standards of quality of raw water and the standards of quality to be required after treatment as per the table No.

The surface sources generally contains large amount of impurities therefore they requires sedimentation, filtration and chlorination as treatment. If the water contains algae or other micro organisms, pre chlorination has to be done tastes and odours , dissolved gases like  $\text{CO}_2$ ,  $\text{H}_2\text{S}$  are removed by aeration. During the flood season , the turbidity of the surface water may be high and flocculation may become necessary to remove turbidity.

Ground water which are usually clear may require only disinfection and chemical treatment for the removal of pathogens, Iron removal, Softening etc.

Sometimes ground water contains dissolved gases like hydrogen sulphide ( $\text{H}_2\text{S}$ ) carbon dioxide ( $\text{CO}_2$ ), which gives very bad odour and requires its removal by aeration.

#### 5.2 TREATMENT UNIT FLOW DIAGRAM

Water treatment includes many operations like Aeration, Flocculation, Sedimentation, Filtration, Softening, Chlorination and demineralization. Depending upon the quality of raw water and the quality of water desired. Several combinations of the above processes may be adopted as shown in the flow diagram.

I. When turbidity of water is less than 10 N.T.U



**GROUND WATER**

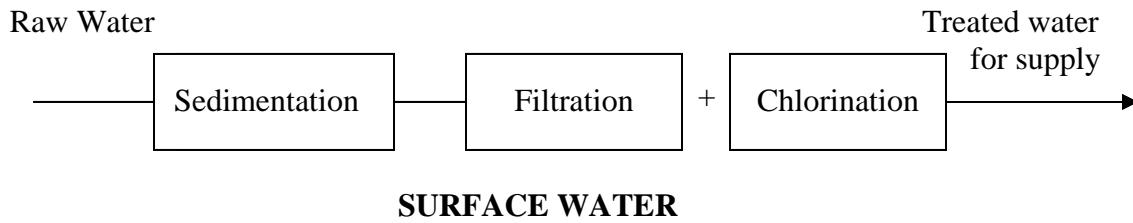

**5.2.1 THE LOCATION OF TRETMENT PLANT**

One complete water treatment plant requires the following process starting from the source of water upto the distribution zone in order of sequence.

Sl.No.	Name of the unit	Purpose
1.	Intake work including pumping plant	Raw water from the source for treatment
2.	Plain sedimentation	To remove suspended impurities such as silt, clay, sand etc.
3.	Sedimentation with coagualtion	To remove the suspended matter
4.	Filtration	To remove microorgans and colloidal matter
5.	Water softening plant	To remove hardness of water
6.	Miscellaneous treatment plants	To remove dissolved gases, tastes and odours.
7.	Disinfection	To remove pathogenic bacteria
8.	Clear water reservoir	To store the treated water
9.	Pumps for pumping the water in service reservoirs	If town or city is situated at higher elevation then pumping is required.
10.	Elevated or underground service reservoir	For distribution of treated water.

**Table 5.1**



The layout of the treatment plant is as shown in the fig 5.1

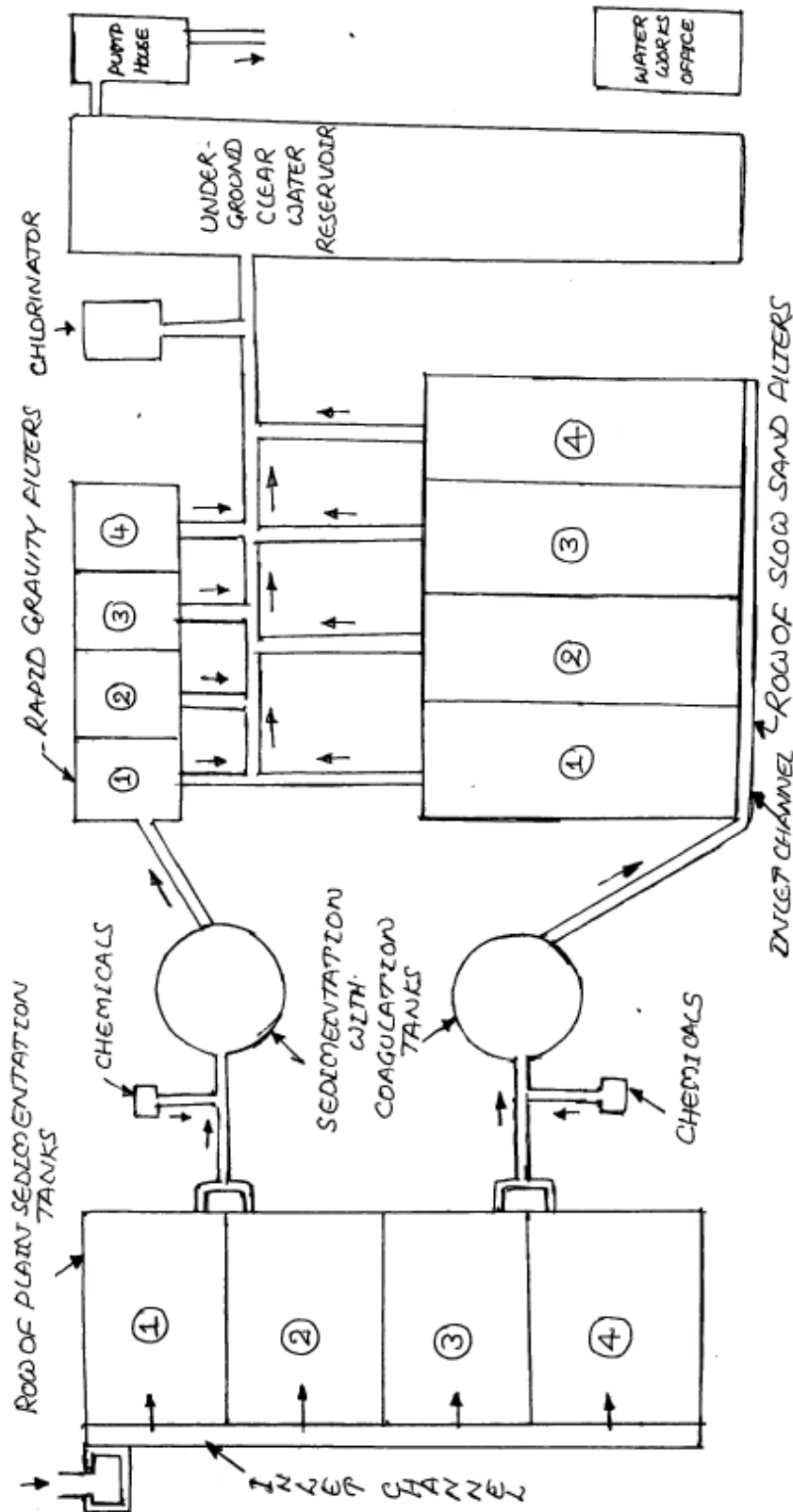

Fig 5.1 Typical Layout of water treatment works

The following points should be kept in mind while giving layout of any treatment plant.

1. The W.T.P. should be located as near to the town so as to avoid the contamination.
2. All the units of plant should be located in order of sequence and flow from one unit to other by gravity.
3. All the units are arranged in such a way that minimum area is required so as to reduce the cost of construction.
4. Sufficient area should be reserved for the future expansion
5. Staff quarters and office should be provided near the treatment plants so that the operators can watch the plants easily.
6. The site of treatment plant should be very neat and give very good asthetic appearance.

### 5.3 SCREENING

Screens are fixed in the intake works or at the entrance of treatment plant so as to remove the floating matters as leaves, dead animals etc.

### 5.4 SEDIMENTATION

It is the process in which the suspended solids are made to settle by gravity under still water conditions is called plain sedimentation.

#### 5.4.1 PLAIN SEDIMENTATION

By plain sedimentation the following are the advantages.

1. Plain sedimentation lightens the load on the subsequent process.
2. The operation of subsequent purification process can be controlled in better way.
3. The cost of cleaning the chemical coagulation basins is reduced.
4. No chemical is lost with sludge discharged from the plain settling basin.
5. Less quantity of chemicals are required in the subsequent treatment processes.

The amount of matter removed by sedimentation tank depends upon the factors.

1. Velocity of flow
2. size and shape of particles
3. Viscosity of water

The particles which do not change in size, shape or mass during settling are known as the discrete particles. The velocity of discrete particles with dia less than 0.1 mm is given by

$$V = 418 (S - S_1) \frac{d^2 (3T + 70)}{100} \quad \text{----- (1)}$$

Where  $V \rightarrow$  Velocity of settlement in mm/sec  
 $S \rightarrow$  Specific gravity of the particle

S<sub>1</sub> → Specific gravity of water  
 D → dia of the particle in mm  
 T → Temperature in °C

If the dia of the particle is greater than 0.1mm then the velocity is measured by

$$V = 418 \frac{(S - S_1) d}{100} (3T + 70) \quad (2)$$

In practice settling of the particles governed by the resultant of horizontal velocity of water and the verticle downward velocity of the particle. The path of the settling particle is as shown in Fig 5.2.

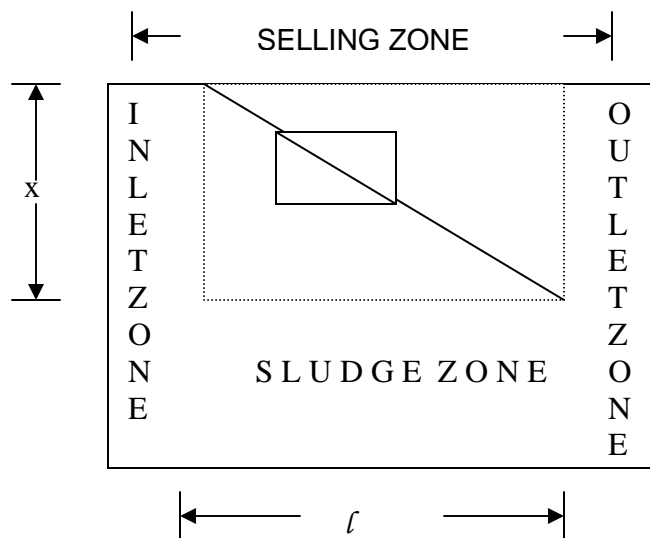

**Fig 5.2 Settling of particles**

### DESIGN ASPECTS OF SEDIMENTATION TANKS

The design aspects of sedimentary tanks are

1. Velocity of flow
  2. Capacity of tank
  3. Inlet and outlet arrangements
  4. Shapes of tanks
  5. Miscellaneous considerations.
- (1) **Velocity of flow:** The velocity of flow of water in sedimentation tanks should be sufficient enough to cause the hydraulic subsidence of suspended impurities. It should remain uniform throughout the tank and it is generally not allowed to exceed 150mm to 300mm per minute.
- (2) **Capacity of tank:** capacity of tank is calculated by i) detention period  
 ii) Overflow rate

- (i) **Detention period:** The theoretical time taken by a particle of water to pass between entry and exit of a settling tank is known as the detention period. The capacity of tank is calculated by

$$C = Q \times T \text{ where } \begin{array}{l} C \rightarrow \text{Capacity of tank} \\ Q \rightarrow \text{Discharge or rate of flow} \\ T \rightarrow \text{Detention period in hours} \end{array}$$

The detention period depends on the quality of suspended impurities present in water. For plain sedimentation tanks, the detention period is found to vary from 4 to 8 hours.

- (ii) **Overflow Rate:** in this method it is assumed that the settlement of a particle at the bottom of the tank does not depend on the depth of tank and depends upon the surface area of the tank.

$$\text{Detention period, } T = \frac{\text{Distance of descend } D}{\text{Velocity of descend } V} = \frac{D}{V} \text{ -----(1)}$$

$$\text{But, } T = \frac{C}{Q} \text{ ----- (2)}$$

From (1) & (2)

$$\frac{C}{Q} = \frac{D}{V}$$

$$\text{Surface overflow rate, } V = \frac{D \cdot Q}{C} = \frac{D \times Q}{L \times B \times D} = \frac{Q}{L \times B}$$

Where  $L \rightarrow$  Length of tank  
 $B \rightarrow$  Breadth of tank  
 $D \rightarrow$  Depth of tank = Side water depth = S.W.D  
 $C \rightarrow$  Capacity of tank  
 $T \rightarrow$  Detention period  
 $U \rightarrow$  Discharge or rate of flow  
 $V \rightarrow$  Velocity of descend of a particle to the bottom of tank  
 $=$  Surface overflow rate = S.O.R

### (3) INLET AND OUTLET ARRANGEMENTS

The inlet is a device, which is provided to distribute the water inside a tank, and the outlet is a device, which is meant to collect outgoing water. These arrangements

should be properly designed and located in a such a way that they do not form any obstruction or cause any disturbance to the flowing water.

#### (4) SHAPES OF TANKS

Following are the three shapes of settling tank.

- (i) Rectangular tanks with horizontal flow
- (ii) Circular tanks with radial or spiral flow
- (iii) Hopper bottom tanks with vertical flow

The following are the parameters for satisfactory performance.

1. Detention period .....	3 to 4 hours for plain settling 2 to 2 1/2 hours for coagulant settling 1 to 1 1/2 hours for up flow type
2. Overflow rate .....	30 – 40 m <sup>3</sup> /m <sup>2</sup> /day for horizontal flow 40-50m <sup>3</sup> /m <sup>2</sup> /day for up flow
3. Velocity of flow.....	0.5 to 1.0 cm/sec
4. Weir loading.....	300m <sup>3</sup> /m/day
5. L:B .....	1:3 to 1:4
Breadth of tank.....	(10 to 12m) to 30 to 50m
6. Depth of tank.....	2 1/2 – 4m
7. Dia of circular tank....	upto 60m
8. Solids removal efficiency.....	50%
9. Turbidity of water after sedimentation –	15 to 20 N.T.U.
10. Inlet and Outlet zones.....	0.75 to 1.0m
11. Free board.....	0.5m
12. Sludge Zone.....	0.5m

#### 5.4.2 SEDIMENTATION AIDED WITH COAGULATION

When water contains fine clay and colloidal impurities which are electrically charged are continually in motion and never settle down due to gravitational force. Certain chemicals are added to the water so as to remove such impurities which are not removed by plain sedimentation. The chemical form insoluble, gelatinous, flocculent precipitate absorbs and entangle very fine suspended matter and colloidal impurities during its formation and descent through water. These coagulants further have an advantage of removing colour, odour and taste from the water. Turbidity of water reduced upto 5-10 ppm and bacteria removes upto 65%.

The following are the mostly used Coagulants with normal dose and PH values required for best floc formation as shown in Table 5.2.

Sl.No.	Coagulant	PH Range	Dosage mg/l
1.	Aluminium sulphate $\text{Al}_2(\text{SO}_4)_3, 18 \text{H}_2\text{O}$	5.5 – 8.0	5 – 85
2.	Sodium Aluminate, $\text{Na}_2\text{Al}_2\text{O}_4$	5.5 – 8.0	3.4 – 34
3.	Ferric Chloride ( $\text{FeCl}_3$ )	5.5 – 11.0	8.5 – 51
4.	Ferric Sulphate $\text{Fe}_2(\text{SO}_4)_3$	5.5 – 11.0	8.5 – 51
5.	Ferric Sulphate $\text{FeSO}_4 \cdot 7\text{H}_2\text{O}$	5.5 – 11.0	8.5 - 51

**Table 5.2**

Coagulants are chosen depending upon the PH of water. Alum or Aluminium sulphate is normally used in all treatment plants because of the low cost and ease of storage as solid crystals over long periods.

The dosage of coagulants, which should be added to the water, depends upon kind of coagulant, turbidity of water, colour of water, PH of water, temperature of water and temperature of water and mixing & flocculation time. The optimum dose of coagulant required for a water treatment plant is determined by a Jar test as shown in Fig 5.2.

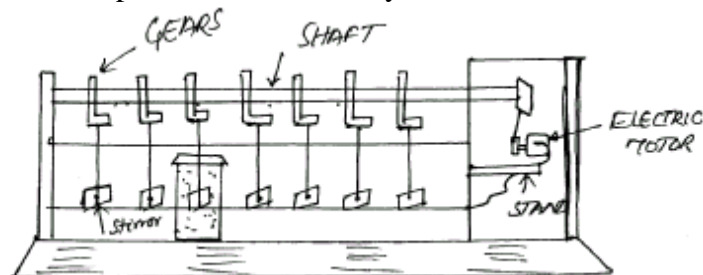

**Fig 5.2 Jar Test Apparatus**

For starting the experiment first of all the sample of water is taken in every jar and added the coagulant in a jar in varying amounts. The quantity of coagulant added in each jar is noted. Then with the help of electric motor all the paddles are rotated at a speed of 30-40 R.P.M. for about 10 minutes. After this the speed is reduced and paddles are rotated for about 20-30 minutes. The rotation of paddles is stopped and the floc formed in each Jar is noted and is allowed to settle. The dose of coagulant which gives the best floc is the optimum dose of coagulants.

The coagulants may be fed or allowed to enter either in powder form called dry feeding or in solution form called wet feeding. The mixing of coagulant with the water to form the floc by the following methods.

1. Centrifugal pump
2. compressed air
3. hydraulic jump
4. mixing channel
5. mixing basins with baffle walls
6. Mixing basins with mechanical means

Now a days some firms manufacture combined unit comprising of feeding, mixing, flocculator and clarifier device. The Fig 5.2 shows used for sedimentation with coagulation.

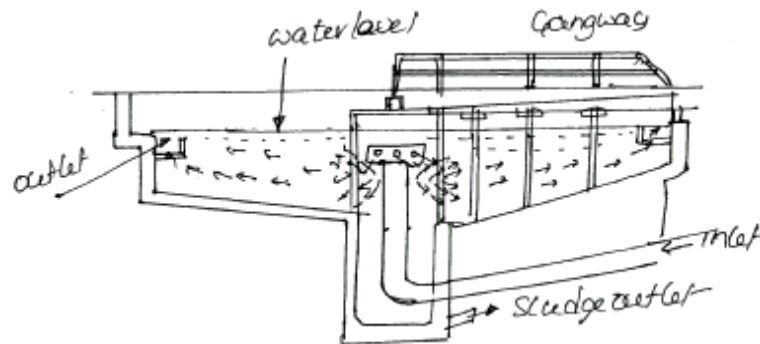

**Fig 5.2 Sedimentation with Coagulation**

Water enters in this tank through central inlet pipe placed inside the deflector box. The deflector box deflects the water downwards and then it goes out through the holes provided sides of the deflector box. The water flows radially from the deflector box towards the circumference of the tank, where outlet is provided on the full periphery as shown in the Fig. All the suspended particles along with floc settle down on the slopy floor and clear water goes through outlet. The sludge is removed by scrapper which continuously moves around the floor with very small velocity.

Disinfection and repainting is to be carried out once in a year before monsoon. Sludge pipes are to be flushed and kept clean. Bleaching powder may be used to control the growth of algae on the weirs. Scraper mechanism should be oiled and greased periodically.

## 5.5 FILTRATION

The process of passing the water through beds of sand or other granular materials is known as filtration. For removing bacteria, colour, taste, odours and producing clear and sparkling water, filters are used by sand filtration 95 to 98% suspended impurities are removed.

### 5.5.1 THEORY OF FILTRATION

The following are the mechanisms of filtration

1. Mechanical straining – Mechanical straining of suspended particles in the sand pores.
2. Sedimentation – Absorption of colloidal and dissolved inorganic matter in the surface of sand grains in a thin film

3. Electrolytic action – The electrolytic charges on the surface of the sand particles, which opposite to that of charges of the impurities are responsible for binding them to sand particles.
4. Biological Action – Biological action due to the development of a film of microorganisms layer on the top of filter media, which absorb organic impurities.

Filtration is carried out in three types of filters

1. Slow sand filter
  2. Rapid sand filter
  3. Pressure filter
- } Gravity filters

### 5.5.1 SLOW SAND FILTER

Slow sand filters are best suited for the filtration of water for small towns. The sand used for the filtration is specified by the effective size and uniformity coefficient. The effective size,  $D_{10}$ , which is the sieve in millimeters that permits 10% sand by weight to pass. The uniformity coefficient is calculated by the ratio of  $D_{60}$  and  $D_{10}$ .

#### CONSTRUCTION

Slow sand filter is made up of a top layer of fine sand of effective size 0.2. to 0.3mm and uniformity coefficient 2 to 3. The thickness of the layer may be 75 to 90 cm. Below the fine sand layer, a layer of coarse sand of such size whose voids do not permit the fine sand to pass through it. The thickness of this layer may be 30cm. The lowermost layer is a graded gravel of size 2 to 45mm and thickness is about 20 to 30cm. The gravel is laid in layers such that the smallest sizes are at the top. The gravel layer is the retains for the coarse sand layer and is laid over the network of open jointed clay pipe or concrete pipes called under drainage. Water collected by the under drainage is passed into the out chamber

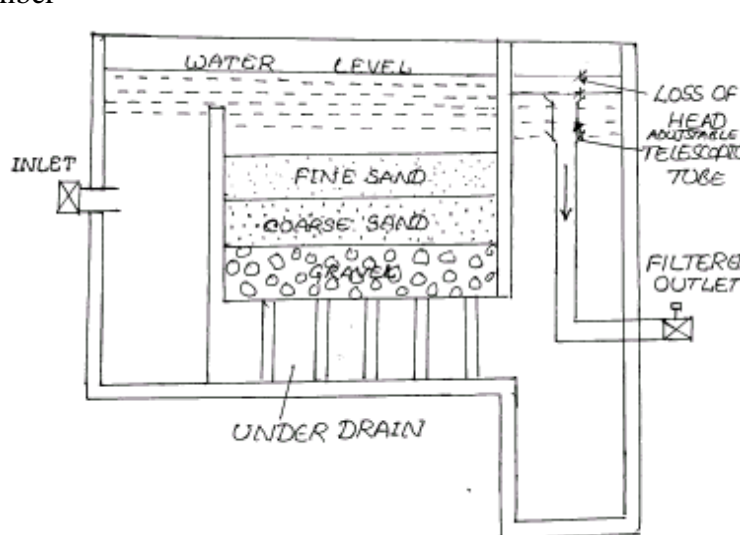

**Fig 5.3 Slow Sand Filter**



## OPERATION

The water from sedimentation tanks enters the slow sand filter through a submersible inlet as shown in fig 5.3 This water is uniformly spread over a sand bed without causing any disturbances. The water passes through the filter media at an average rate of 2.4 to 3.6 m<sup>3</sup>/m<sup>2</sup>/day. This rate of filtration is continued until the difference between the water level on the filter and in the inlet chamber is slightly less than the depth of water above the sand. The difference of water above the sand bed and in the outlet chamber is called the loss of head.

During filtration as the filter media gets clogged due to the impurities, which stay in the pores, the resistance to the passage of water and loss of head also increases. When the loss of head reaches 60cm, filtration is stopped and about 2 to 3 cms from the top of bed is scrapped and replaced with clean sand before putting back into service to the filter. The scrapped sand is washed with the water, dried and stored for return to the filter at the time of the next washing . The filter can run for 6 to 8 weeks before it becomes necessary to replace the sand layer.

## USES

The slow sand filters are effective in removal of 98 to 99% of bacteria of raw water and completely all suspended impurities and turbidity is reduced to 1 N.T.U. Slow sand filters also removes odours, tastes and colours from the water but not pathogenic bacteria which requires disinfection to safeguard against water-borne diseases. The slow sand filters requires large area for their construction and high initial cost for establishment. The rate of filtration is also very slow.

## MAINTENANCE

The algae growth on the overflow weir should be stopped. Rate of filtration should be maintained constant and free from fluctuation. Filter head indicator should be in good working condition. Trees around the plant should be controlled to avoid bird droppings on the filter bed, No coagulant should be used before slow sand filtration since the floc will clog the bed quickly.

### 5.5.2 RAPID SAND FILTER

Rapid sand filter are replacing the slow sand filters because of high rate of filtration ranging from 100 to 150m<sup>3</sup>/m<sup>2</sup>/day and small area of filter required. The main features of rapid sand filter are as follows.

The main features of rapid sand filter are as follows

Effective size of sand	-	0.45 to 0.70mm
Uniformity coefficient of sand	-	1.3 to 1.7

Depth of sand	-	60 to 75cm
Filter gravel	-	2 to 50mm size (Increase size towards bottom)
Depth of gravel	-	45cm
Depth of water over sand during filtration	-	1 to 2m
Overall depth of filter including 0.5m free board	-	2.6m
Area of single filter unit	-	100m <sup>2</sup> in two parts of each 50m <sup>2</sup>
Loss of head	-	Max 1.8 to 2.0m
Turbidity of filtered water	-	1 NTU

## OPERATION

The water from coagulation sedimentation tank enters the filter unit through inlet pipe and uniformly distributed on the whole sand bed. Water after passing through the sand bed is collected through the under drainage system in the filtered water well. The outlet chamber in this filter is also equipped with filter rate controller. In the beginning the loss of head is very small. But as the bed gets clogged, the loss of head increases and the rate of filtration becomes very low. Therefore the filter bed requires its washing.

## WASHING OF FILTER

Washing of filter done by the back flow of water through the sand bed as shown in Fig 5.5.

First the valve 'A' is closed and the water is drained out from the filter leaving a few centimeter depth of water on the top of sand bed. Keeping all valves closed the compressed air is passed through the separate pipe system for 2-3 minutes, which agitates the sand bed and stirrer it well causing the loosening of dirt, clay etc. inside the sand bed. Now valve 'C' and 'B' are opened gradually, the wash water tank, rises through the laterals, the strainers gravel and sand bed. Due to back flow of water the sand expands and all the impurities are carried away with the wash water to the drains through the channels, which are kept for this purpose.

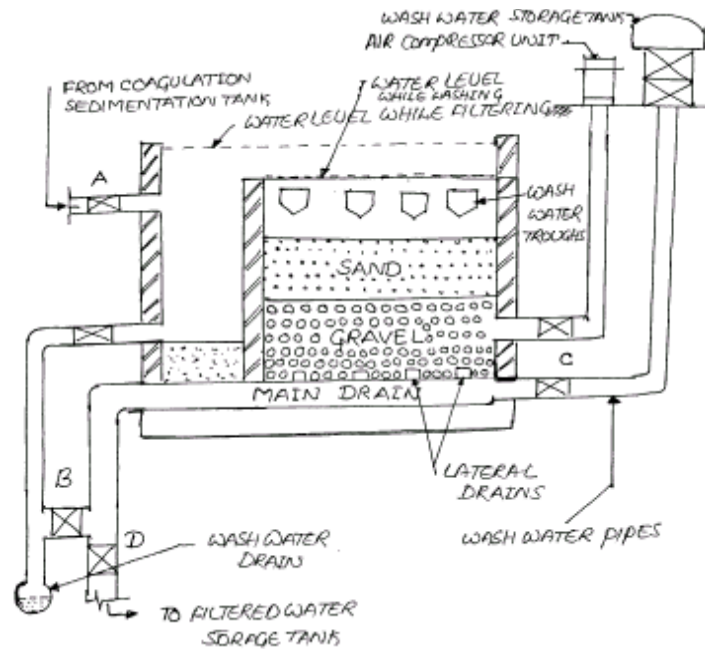

**Fig 5.5 Rapid Sand Filter**

## CONSTRUCTION

Rapid sand filter consists of the following five parts

1. Enclosure tank – A water tight tank is constructed either masonry or concrete
2. Under drainage system – may be perforated pipe system or pipe and stracher system
3. Base material – gravel should free from clay, dust, silt and vegetable matter. Should be durable, hard, round and strong and depth 40cm.
4. Filter media of sand – The depth of sand 60 to 75cm
5. Appartenances – Air compressors useful for washing of filter and wash water troughs for collection of dirty water after washing of filter.

Washing process is continued till the sand bed appears clearly. The eashing of filter is done generally after 24 hours and it takes 10 minutes and during back washing the sand bed expands by about 50%.

Rapid sand filter bring down the turbidity of water to 1 N.T.U. This filter needs constant and skilled supervision to maintain the filter gauge, expansion gauge and rate of flow controller and periodical backwash.

**Table 5.3 Comparison of slow sand filter and rapid sand filter**

Sl.No.	ITEM	S.S.F	R.S.F
1.	Area	Need very large area	Needs small area
2.	Raw Water Turbidity	Not more than 30 NTU	Not more than 10NTU hence needs coagulation
3.	Sand Media	Effective size 0.2 to 0.3 mm uniformity coefficient 2 to 3 single layer of uniform size	Effective size 0.45 to 0.7 mm uniformity coefficient 1.3 to 1.7 multiple graded layers of sand.
4.	Rate of Filtration	2.4 to 3.6m <sup>3</sup> /m <sup>2</sup> /day	100-150 m <sup>3</sup> /m <sup>2</sup> /day
5.	Loss of Head	0.6m to 0.7 m	1.8m to 2.0m
6.	Supervision	No skilled supervision is required	Skilled supervision is required
7.	Cleaning of Filter	Scraping of 21/2cm thick layer washing and replacing. Cleaning interval that is replacement of sand at 1 to 2 months.	Back wash with clean water under pressure to detach the dirt on the sand. Backwashing daily or on alternate days.
8.	Efficiency	Bacterial removal, taste, odour, colour and turbidity removal.	There is no removal of bacteria. Removal colour taste, odour and turbidity is good.

#### 5.5.4 PRESSURE FILTER

Pressure filter is type of rapid sand filter in a closed water tight cylinder through which the water passes through the sand bed under pressure. All the operations of the filter is similar to rapid gravity filter, except that the coagulated water is directly applied to the filter without mixing and flocculation. These filters are used for industrial plants but these are not economical on large scale.

Pressure filters may be vertical pressure filter and horizontal pressure filter. The Fig 5.5 shows vertical pressure filter. Backwash is carried by reversing the flow with values. The rate of flow is 120 to 300m<sup>3</sup>/m<sup>2</sup>/day.

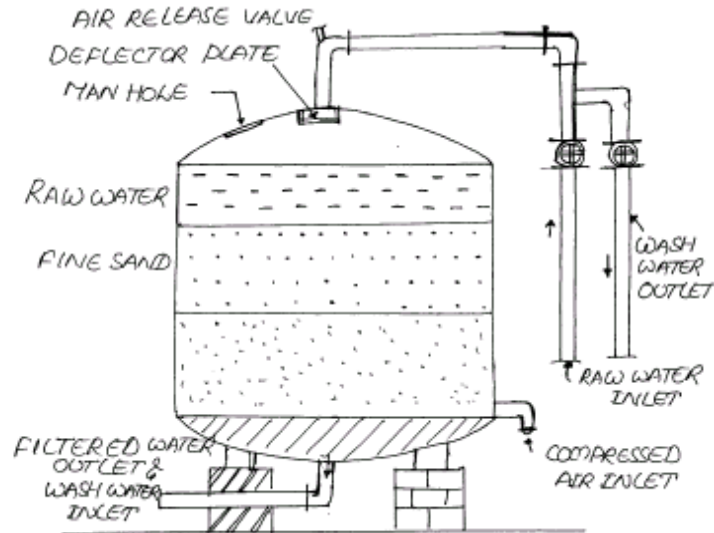

**Figure 5.6 Vertical Pressure Filter**

### **ADVANTAGES**

1. It is a compact and automatic operation
2. These are ideal for small estates and small water works
3. These filters requires small area for installation
4. Small number of fittings are required in these filters
5. Fitered water comes out under pressure no further pumping is required.
6. No sedimentation and coagulant tanks are required with these units.

### **DISADVATAGES**

1. Due to heavy cost on treatment , they cannot be used for treatment large quantity of water at water works
2. Proper quality control and inspection is not possible because of closed tank
3. The efficiency of removal of bacteria & turbidity is poor.
4. Change of filter media, gravel and repair of drainage system is difficult.

## **5.6 DISINFECTION OF WATER**

The process of killing the infective bacteria from the water and making it safe to the user is called disinfection. The water which comes out from the filter may contain some disease – causing bacteria in addition to the useful bacteria. Before the water is supplied to the public it is utmost necessary to kill all the disease causing bacteria. The

chemicals or substances which are used for killing the bacteria are known as disinfectants.

## **REQUIREMENTS OF GOOD DISINFECTANTS**

1. They should destroy all the harmful pathogens and make it safe for use,.
2. They should not take more time in killing bacteria
3. They should be economical and easily available
4. They should not require high skill for their application
5. After treatment the water should not become toxic and objectionable to the user.
6. The concentration should be determined by simply and quickly.

### **5.6.1 METHODS OF DISINFECTION**

Disinfection of water by different physical and chemical methods

#### **I. PHYSICAL METHODS**

1. **BOILING** : Boil the water for 15 to 20 minutes and kills the disease causing bacteria. This process is applicable for individual homes.
2. **ULTRA-VIOLET RAYS**: Water is allowed to pass about 10cm thickness by ultraviolet rays. This process is very costly and not used at water works. Suitable for institutions.
3. **ULTRASONIC RAYS**: Suitable for institutions.

#### **II. CHEMICAL METHODS**

1. **CHLORINATION** : Using chlorine gas or chlorine compounds.
2. **BROMINE AND IODINE** : It is expensive and leaves taste and odour.
3. **POTASSIUM PERMANGANATE**: This method is used for disinfection of dug well water, pond water or private source of water.
4. **OZONE** : Very expensive process, leaves no taste, odour or residual.
5. **EXCESS LIME TREATMENT**: Needs long detention time for time interval and large lime sludges to be treated.

## 5.6.2 CHLORINATION

Chlorination is the addition of chlorine to kill the bacteria Chlorination is very widely adopted in all developing countries for treatment of water for public supply. Chlorine is available in gas, liquid or solid form (bleaching powder)

### ADVANTAGES OF CHLORINE

1. Chlorine is manufactured easily by electrolytes of common salts (NaCl)
2. It is powerful oxidant and can penetrate the cell wall of organism and its contents.
3. Dosage can be controlled precisely
4. can be easily detected by simple orthotolidine test
5. Doesnot form harmful constituents on reaction with organics of inorganics in water
6. leaves required residue in water to neutralise recontamination later.

### PRECAUTIONS IN USING CHLORINE

1. Chlorine gas or liquid is highly corrosive and Lital to Inhale. Hence it is to be stored carefully in sealed container at a distance.
2. If the water contains phenolic compounds, there is a reaction with chlorine can result in cancer causing substances.

### RESIDUAL CHLORINE AND CHLORINE DEMAND

When chlorine is applied in water some of it is consumed in killing the pathogens, some react organs & inorganic substances and the balance is detected as “Residual Chlorine”. The difference between the quantity applied per litre and the residual is called “Chlorine Demand”. Polluted waters exert more chlorine demand. If water is pre-treated by sedimentation and aeration, chlorine demand may be reduced. Normally residual chlorine of 0.2 mg/litre is required.

### BEHAVIER OF CHLORINE IN WATER

When chlorine is dissolved in water forms hypo chlorous acid and hydro chloric acid.



After some time hydro chlorous acid further Ionizes as follows

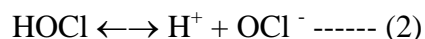

The two prevailing species (HOCl) and (OCl<sup>-</sup>) are called free available chlorine are responsible for the disinfection of water.

Chlorine reacts with ammonia in water to form Monochloramine, ( $\text{NH}_2\text{Cl}$ ), dichloramine ( $\text{NHCl}_2$ ) and trichloramine, ( $\text{NCl}_3$ ) released and their distribution depends on the PH-value of water.

## DOSAGE OF CHLORINE

### (A) PLAIN CHLORINATION

Plain chlorination is the process of addition of chlorine only when the surface water with no other treatment is required. The water of lakes and springs is pure and can be used after plain chlorination. A rate of 0.8 mg/lit/hour at  $15\text{N}/\text{cm}^2$  pressure is the normal dosage so as to maintain in a residual chlorine of 0.2 mg/lit.

### (B) SUPER CHLORINATION

Super chlorination is defined as administration of a dose considerably in excess of that necessary for the adequate bacterial purification of water. About 10 to 15 mg/lit is applied with a contact time of 10 to 30 minutes under the circumstances such as during epidemic breakout water is to be dechlorinated before supply to the distribution system.

### (C) BRAKE POINT CHLORINATION

When chlorine is applied to water containing organics, micro organisms and ammonia the residual chlorine levels fluctuate with increase in dosage as shown in Fig. 5.6.

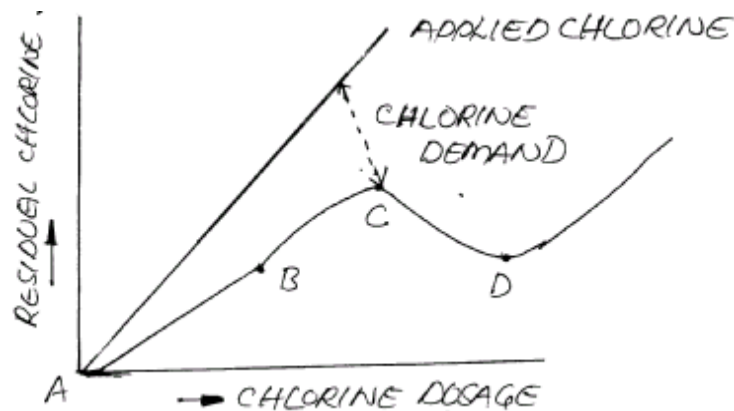

Fig 5.6

Upto the point B it is absorbed by reducing agents in water (like nitrates, Iron etc) further increases forms chloramines with ammonia in water. Chloramines are effective as CL and OCL formed. When the free chlorine content increases it reacts with the chloramines and reducing the available chlorine. At the point 'D' all the



chloramines are converted to effective  $N_2$ ,  $N_2O$  and  $NCl_3$ . Beyond point 'D' free residual chlorine appear again. This point 'D' is called break point chlorination. Dosage beyond this point is the same as super chlorination. In super chlorination no such rational measurement is made and the dosage is taken at random.

**(D) DECHLORINATION**

Removal of excess chlorine resulting from super chlorination in part or completely is called 'Dechlorination'. Excess chlorine in water gives pungent smell and corrode the pipe lines. Hence excess chlorine is to be removed before supply. Physical methods like aeration, heating and absorption on charcoal may be adopted. Chemical methods like sulphur dioxide ( $SO_2$ ) , Sodium Bi-sulphate ( $NaHSO_3$ ), Sodium Thiosulphate( $Na_2S_2O_8$ ) are used.

**POINTS OF CHLORINATION**

Chlorine applied at various stages of treatment and distribution accordingly they are known as pre, post and Re-chlorination.

**a) PRE-CHLORINATION**

Chlorine applied prior to the sedimentation and filtration process is known as Pre-chlorination. This is practiced when the water is heavily polluted and to remove taste, odour, colour and growth of algae on treatment units. Pre-chlorination improves coagulation and post chlorination dosage may be reduced.

**b) POST CHLORINATION**

When the chlorine is added in the water after all the treatment is known as Post-chlorination.

**c) RE-CHLORINATION**

In long distribution systems, chlorine residual may fall tendering the water unsafe. Application of excess chlorine to compensate for this may lead to unpleasant smell to consumers at the points nearer to treatment point in such cases chlorine is applied again that is rechlorinated at intermediate points generally at service reservoirs and booster pumping stations.

**5.7 DEFLUORIDATION – BY NALGONDA TECHNIQUE**

Defluoridation is process of removal of excess fluoride present in the water. The excess fluoride in the water causes dental abnormalities, hypertension, peptic ulcer, Skin infections, defective vision, coronary thrombosis etc. The permissible level of fluoride in the water is 1mg/litre.

## METHODS OF REMOVAL

1. Activated carbons prepared from various materials can be used.
2. Lime – soda process of water softening removes fluorides also along with magnesium
3. The materials like calcium phosphate, bone charcoal, synthetic tricalcium phosphate a may remove excess fluoride.
4. the water may be allowed to pass through filter beds containing fluoride retaining materials.

In this technique, sodium aluminate or lime, bleaching powder and filter alum are added to fluoride water in sequence. The water is stored for ten minutes and settled for one hour and the water is then withdrawn without disturbing the sediments. The sodium aluminate or lime accelerates the settlement of precipitate and bleaching powder ensures disinfection. The alum dose required will depend upon the concentration of fluorides, alkalinity and total dissolved solids in the raw water. It is found that this technique is simple in operation and economical. It can be used with advantage in villages either on an individual scale or on a mass scale.

## SUMMARY

1. Water treatment processes are
  - a. Sedimentation
  - b. Filtration
  - c. Disinfection
2. Sedimentation is for removal of suspended solids in the water. In plain sedimentation 30 to 40% of solids are removed with detention period of 3 hours. In coagulant aided sedimentation removes colloids and suspended solids upto 70% with a detention period of 2 – 2 1/2 hours. Coagulants used are alum, Sodium aluminate, ferric chloride, etc. and Jar test is used to determine coagulant dosage.
3. Filtration is the process of passing the water through sand medium. In slow sand filter the effective size of sand used is 0.2 to 0.3 mm and removes bacteria (90%) , colour , turbidity , taste and odour . Rate of filtration is 2.5 to 3.6 m<sup>3</sup>/m<sup>2</sup>/day . In rapid sand filter the effective size of sand used is 0.45 to 0.7 mm . It can not remove bacteria. Colour , odour, taste and turbidity can be removed . For cleaning of rapid sand filter back washing is used. Pressure filter is the same as rapid sand filter excepting the filtration is carried at high pressure.
4. Disinfection is the process of killing of pathogenic bacteria by the methods of boiling, U.V.rays, chlorine, bromine, iodine, excess lime, Ozone, Potassium permanganate. Residual chlorine of 0.2 mg/litre is required to safeguard against contamination of water during distribution.

### SHORT ANSWER QUESTIONS

1. Define sedimentation.
2. What are the advantages of sedimentation?
3. State the factors that effect sedimentation.
4. What is meant by coagulation?
5. State any four coagulants.
6. State any two mechanisms involved in filtration.
7. What is negative head in the filtration?
8. State any four methods of disinfection of water.
9. State any two advantages of chlorination.
10. Define Residual Chlorine.
11. What is disinfection of water?
12. What is meant by dechlorination?
13. Name any four diseases caused by excess presence of fluoride in water.
14. Define pre chlorination.
15. Define post chlorination.

### ESSAY TYPE QUESTIONS

1. What are the points to be considered for locating a treatment plant?
2. Explain slow sand filter with neat slatch.
3. Explain working of rapid sand filter with the help of neat sketch.
4. List out the requirements of good disinfectant.
5. What do you understand by break point chlorination?
6. What are the differences of slow sand filter and rapid sand filter?
7. What are the effects of fluorine? How you remove the fluorine by Nelgonda Technique.
8. Explain  
a) pre-chlorination      b) post-chlorination  
c) de-chlorination      c) re-chlorination
9. Explain the backwashing of rapid sand filter.

## **CHAPTER 6**

### **DISTRIBUTION OF WATER**

#### **6.1 GENERAL INTRODUCTION:**

After treatment, water is to be stored temporarily and supplied to the consumers through the network of pipelines called distribution system. The distribution system also includes pumps, reservoirs, pipe fittings, instruments for measurement of pressures, flow leak detectors etc. The cost of distribution is about 40 to 70% of the total cost of the entire scheme. The efficiency of the system depends upon proper planning, execution and maintenance. Ultimate aim is to supply potable water to all the consumers whenever required in sufficient quantity with required pressure with least loss and without any leakage.

#### **6.2 REQUIREMENT OF A DISTRIBUTION SYSTEM:**

1. It should convey the treated water upto consumers with the same degree of purity
2. The system should be economical and easy to maintain and operate
3. The diameter of pipes should be designed to meet the fire demand
4. It should be safe against any future pollution. As far as possible should not be laid below sewer lines.
5. Water should be supplied without interruption even when repairs are undertaken
6. The system should be so designed that the supply should meet maximum hourly demand. A peak factor 2.5 is recommended for the towns of population 0.5. to 2 lakhs. For larger population a factor of 2.0 will be adequate.

#### **6.3 LAYOUTS OF DISTRIBUTION SYSTEM:**

Generally in practice there are four different systems of distribution which are used. They are:

1. Dead End or Tree system
2. Grid Iron system
3. Circular or Ring system
4. Radial system

### 6.3.1 DEAD END OR TREE SYSTEM:

This system is suitable for irregular developed towns or cities. In this system water flows in one direction only into submains and branches. The diameter of pipe decreases at every tree branch.

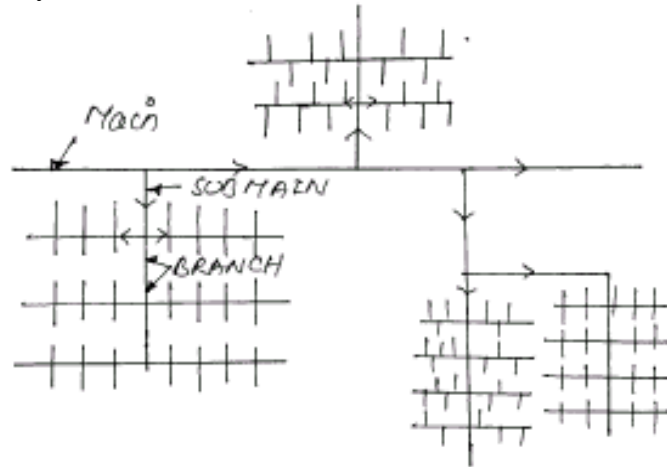

**Fig 6.1 Dead End System**

#### ADVANTAGES

1. Discharge and pressure at any point in the distribution system is calculated easily
2. The valves required in this system of layout are comparatively less in number.
3. The diameter of pipes used are smaller and hence the system is cheap and economical
4. The laying of water pipes is used are simple.

#### DISADVANTAGES

1. There is stagnant water at dead ends of pipes causing contamination.
2. During repairs of pipes or valves at any point the entire down stream end are deprived of supply
3. The water available for fire fighting will be limited in quantity

### 6.3.2. GRID IRON SYSTEM

From the mains water enters the branches at all Junctions in either directions into submains of equal diameters. At any point in the line the pressure is balanced from two directions because of interconnected network of pipes.

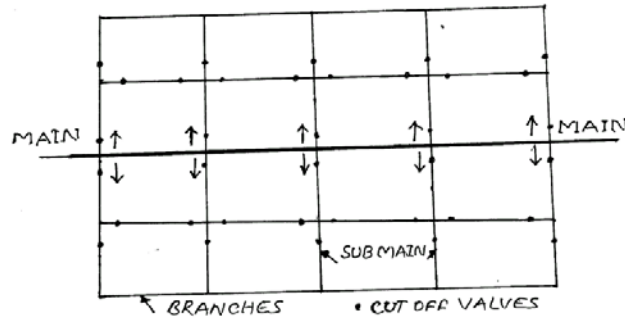

**Fig 6.2 Grid – Iron Method**

**ADVANTAGES**

1. In the case of repairs a very small portion of distribution are a will be affected
2. Every point receives supply from two directions and with higher pressure
3. Additional water from the other branches are available for fire fighting
4. There is free circulation of water and hence it is not liable for pollution due to stagnation.

**DISADVANTAGES**

1. More length of pipes and number of valves are needed and hence there is increased cost of construction
2. Calculation of sizes of pipes and working out pressures at various points in the distribution system is laborious , complicated and difficult.

**6.3.3 CIRCULAR OR RING SYSTEM**

Supply to the inner pipes is from the mains around the boundary. It has the same advantages as the grid-Iron system. Smaller diameter pipes are needed. The advantages and disadvantages are same as that of grid-Iron system.

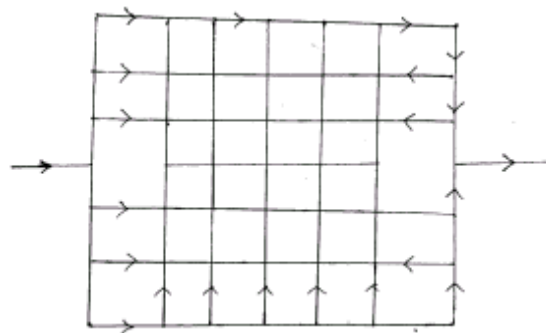

**Fig 6.3 Circular of Ring System**

### 6.3.4 RADIAL SYSTEM:

This is a zoned system. Water is pumped to the distribution reservoirs and from the reservoirs it flows by gravity to the tree system of pipes. The pressure calculations are easy in this system. Layout of roads need to be radial to eliminate loss of head in bends. This is most economical system also if combined pumping and gravity flow is adopted.

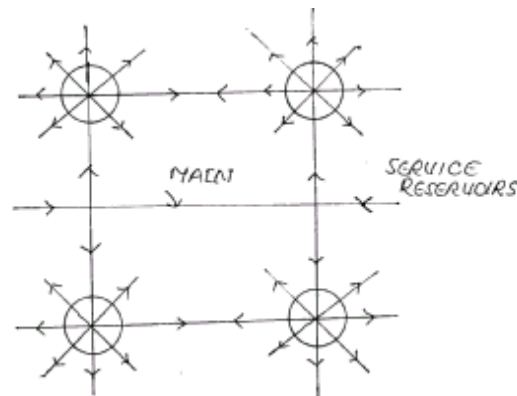

**Fig. 6.4 Radial System**

### 6.4. SYSTEM OF DISTRIBUTION:

For efficient distribution it is required that the water should reach to every consumer with required rate of flow. Therefore, some pressure in pipeline is necessary, which should force the water to reach at every place. Depending upon the methods of distribution, the distribution system is classified as the follows:

1. Gravity system
2. Pumping system
3. Dual system or combined gravity and pumping system

#### 6.4.1 GRAVITY SYSTEM:

When some ground sufficiently high above the city area is available, this can be best utilized for distribution system in maintaining pressure in water mains. This method is also much suitable when the source of supply such as lake, river or impounding reservoir is at sufficiently higher than city. The water flows in the mains due to gravitational forces. As no pumping is required therefore it is the most reliable system for the distribution of water as shown in fig. 6.5

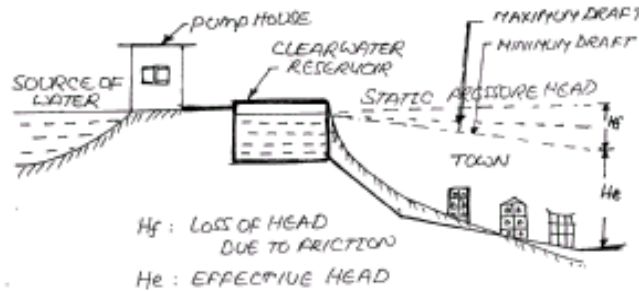

**FIG 6.5 Gravity System**

**6.4.2 PUMPING SYSTEM:**

Constant pressure can be maintained in the system by direct pumping into mains. Rate of flow cannot be varied easily according to demand unless number of pumps are operated in addition to stand by ones. Supply can be effected during power failure and breakdown of pumps. Hence diesel pumps also in addition to electrical pumps as stand by to be maintained. During fires, the water can be pumped in required quantity by the stand by units.

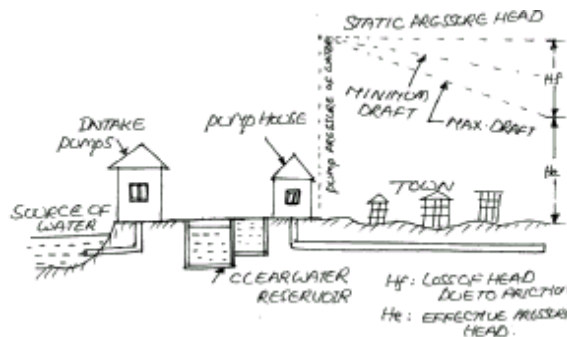
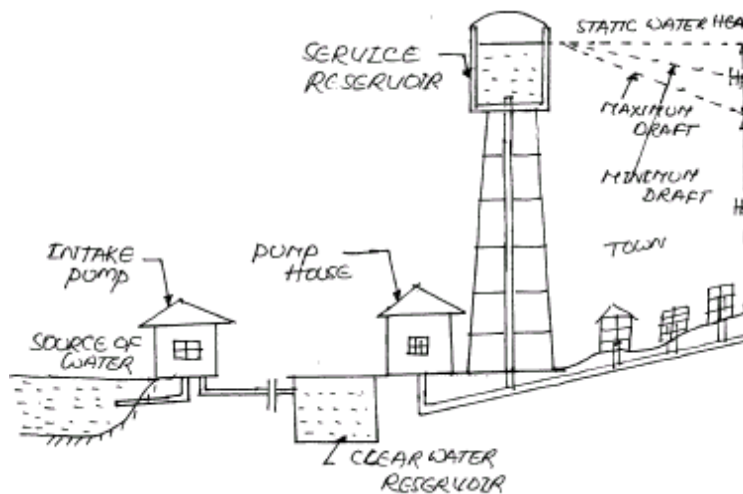

**Fig 6.6 Pumping System**

**6.4.3 COMBINED PUMPING AND GRAVITY SYSTEM:**

This is also known as dual system. The pump is connected to the mains as well as elevated reservoir. In the beginning when demand is small the water is stored in the elevated reservoir, but when demand increases the rate of pumping, the flow in the distribution system comes from the both the pumping station as well as elevated reservoir. As in this system water comes from two sources one from reservoir and second from pumping station, it is called dual system. This system is more reliable and economical, because it requires uniform rate of pumping but meets low as well as maximum demand. The water stored in the elevated reservoir meets the requirements of demand during breakdown of pumps and for fire fighting.





**FIG 6.7 Dual System of Distribution**

The water may be supplied to the consumers by either of the two systems.

### 1. CONTINUOUS SYSTEM

This is the best system and water is supplied for all 24 hours. This system is possible when there is adequate quantity of water for supply. In this system sample of water is always available for fire fighting and due to continuous circulation water always remains fresh. In this system less diameter of pipes are required and rusting of pipes will be less. Losses will be more if there are leakages in the system.

### 2. INTERMITTENT SYSTEM

If plenty of water is not available, the supply of water is divided into zones and each zone is supplied with water for fixed hours in a day or on alternate days. As the water is supplied after intervals, it is called intermittent system. The system has following disadvantages:

1. Pipelines are likely to rust faster due to alternate wetting and drying. This increases the maintenance cost.
2. There is also pollution of water by ingress of polluted water through leaks during non-flow periods.
3. More wastage of water due to the tendency of the people to store more water than required quantity and to waste the excess to collect fresh water each time.

In spite of number of disadvantages, this system is usually adopted in most of the cities and towns of India. In this system water can be supplied in the high level localities with adequate pressure by dividing the city in zones. The repair work can be easily done in the non-supply hours.

## 6.5 PUMPS

The function of pump is to lift the water or any fluid to higher elevation or at higher pressure. Pumps are driven by electricity, diesel or steam power. They are helpful in pumping water from the sources, that is from intake to the treatment plant and from treatment plant to the distribution system or service reservoir. In homes also pumps are used to pump water to upper floors or to store water in tanks over the buildings.

### 6.5.1 TYPES OF PUMPS AND THEIR SUITABILITY

Based on the mechanical principle of water lifting pumps are classified as the following

Sl.No	Type of Pump	Examples	Suitability
1.	Displacement pumps	Reciprocating pumps. Rotary, chain, gear wheel, pump and wind mills.	This type of pumps are suitable for moderate heads and small discharges suitable for fire protection, water supply of individual houses.
2.	Velocity pumps	Centrifugal pumps, deep well, turbine pumps, jet pumps	This type of pumps are used widely in water supply schemes containing sand, silt etc.
3.	Boyancy pumps	Airlifting pumps	Airlifting pumps are generally adopted for pumping of water from deep wells to a lift of about 60m containing mud, silt, debris etc.
4.	Impulse pumps	Hydraulic Ram	Used for Small water supply projects to lift the water for a height of about 30m or so.

### 6.5.2 CENTRIFUGAL PUMPS – COMPONENTS

Centrifugal force is made use of in lifting water. Electrical energy is converted to potential or pressure energy of water.

#### COMPONENT PARTS OF CENTRIFUGAL PUMP

Centrifugal pump consists of the following parts as shown in fig 6.8

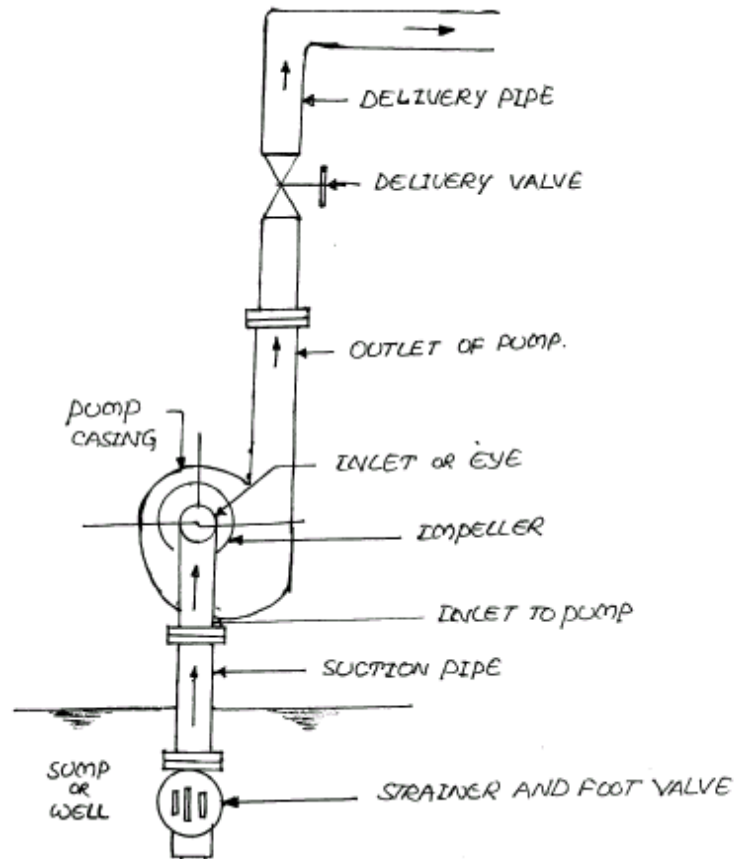

**Figure 6.8 Centrifugal Pump**

1. CASING: The impeller is enclosed in the casing, which is so designed that kinetic energy of the liquid is converted into pressure energy before it leaves the casing.
2. Delivery pipe
3. Delivery valve
4. Impeller
5. Prime mover
6. Suction pipe
7. Strainer and foot valve

**DESCRIPTION**

The pump consists of an Impeller enclosed in a water tight casing. Water at lower level is sucked into the impeller through a suction pipe. Suction pipe should be air tight and bends in this pipe should be avoided. A strainer foot valve is connected at the bottom of the suction pipe to prevent entry of foreign matter and to hold water during

pumping . Suction pipe is kept larger in diameter than delivery pipe to reduce cavitations and losses due to friction.

An electric motor is coupled to the central shaft to impart energy.

## **WORKING PRINCIPLE**

When the impellor starts rotating it creates reduction of pressure at the eye of the impellor, which sucks in water through the suction pipe. Water on entering the eye is caught between the vanes of the impeller. Rapid rotation of the impellor sets up a centrifugal force and forces the water at high velocity outwards against the casing causing the water to convert the velocity energy into pressure energy which is utilized to overcome the delivery head

### **6.5.4. OPERATION AND MAINTENANCE**

Priming – Priming means filling up of the suction and casing completely with water.

Pressure and suction developed by the impellor is proportional to the density of the fluid and the speed of rotation. Impellor running in air will produce only negligible negative pressure on the head. Hence it is required that the casing and impellor is filled with water through a funnel and cock. Trapped air is released through pet cock. Initially the delivery valve is closed and the pump started. The rotation impellor pushes the water in the casing into the delivery pipe and the water in the casing into the delivery pipe and the resulting vacuum is filled by water raising through the suction pipe. The pass valve is opened while closing the bypass valve , while stopping the pump delivery valve is closed first and the pump switched off.

Maintenance may be 1) preventive maintenance 2) Break down maintenance.

#### **Preventive maintenance**

Locates the sources of trouble and keep the equipment in good operating condition. It involves oiling, greasing of stuffing boxes, observing the temperature of the motor and the pump bearings, checking the valves, strainer, electrical contacts, earthings etc.

#### **Break down maintenance**

Involves replacement of wornout components and testing . Sufficient amount of spares of impellers, bearings, slip-ring brushes, stator-contacts, gland packing, greases, oils, jointing materials, valves are to be kept instock to attend to the emergencies. It is usual to have one stand by pump in addition to the required number of pumps.

### 6.5.3 SELECTION OF PUMP HORSE POWER

Basic data regarding the water availability like diameter, depth of the well, depth of the water table, seasonal variations of water table, drawdown duration of pumping and safe yield are to be collected accurately before selecting a pump.

There are many varieties of specifications and choices available in the market and it is a tricky problem facing an engineer to select the best suited for his requirement.

#### POINT TO BE OBSERVED IN SELECTING A PUMP

1. Capacity and efficiency - The pump should have the capacity required and optimum efficiency.
2. Lift - Suction head from the water level to the pump level
3. Head – It is also called delivery head. Generally the total head (suction and delivery head) should meet all possible situations with respect to the head.
4. Reliability – A reputed manufacture or similar make pump already in use may give the failure rate and types of troubles.
5. Initial cost: The cost of the pump and its installation cost should be minimum.
6. Power – Power requirements should be less for operation
7. Maintenance – Maintenance cost should be minimum. Availability of spares and cost of spares are to be ascertained.

#### HORSE-POWER OF PUMP

The horse-power (H.P.) of a pump can be determined by calculated the work done by a pump in raising the water upto H height.

Let the pump raise 'W' kg of water to height 'H' m

Then workdone by pump = W X H Kg m

= WQH mkg/sec

Where W → density of water in kg/m<sup>3</sup>.

Q → water discharge by pump in m<sup>3</sup>/sec

$$\text{The water horse power} = \frac{\text{Discharge} \times \text{Total head}}{75}$$

$$\text{W.H.P.} = \frac{W \times Q \times H}{75}$$

$$\text{Break Horse Power} = \frac{W. H. P}{\text{Efficiency}}$$

$$= \frac{W. H. P}{75 \times \eta}$$

## 6.6 PIPES AND REQUIREMENTS

Pipes convey raw water from the source to the treatment plants in the distribution system. Water is under pressure always and hence the pipe material and the fixture should withstand stresses due to the internal pressure, vacuum pressure, when the pipes are empty, water hammer when the valves are closed and temperature stresses.

### REQUIREMENTS OF PIPE MATERIAL

1. It should be capable of with standing internal and external pressures
2. It should have facility of easy joints
3. It should be available in all sizes, transport and erection should be easy.
4. It should be durable
5. It should not react with water to alter its quality
6. Cost of pipes should be less
7. Frictional head loss should be minimum
8. The damaged units should be replaced easily.

#### 6.6.1 DIFFERENT TYPES OF PIPES

The following are the different types of pipes

1. Cast Iron
2. Steel
3. Prestressed concrete
4. R.C.C

5. A.C. Pipes
6. Galvanised Iron (G.I)
7. P.V.C and plastic pipes

**6.6.1 DIFFERENT TYPES OF PIPES**

Sl.No.	Type of Pipe	Advantages	Disadvantages
1.	Cast iron Pipes	<ol style="list-style-type: none"> <li>1. Cost is moderate</li> <li>2. The pipes are easy to join</li> <li>3. The pipes are not subjected to corrosion</li> <li>4. The pipes are strong and durable</li> <li>5. Service connections can be easily made</li> <li>6. Usual life is about 100 years</li> </ol>	<ol style="list-style-type: none"> <li>1. Breakage of pipes are large</li> <li>2. The carrying capacity of these pipes decreases with the increase in life of pipes.</li> <li>3. The pipes are not used for pressure greater than 0.7 N/mm<sup>2</sup></li> <li>4. The pipes are heavier and uneconomical beyond 1200 mmdia.</li> </ol>
2.	steel Pipes	<ol style="list-style-type: none"> <li>1. No. of Joinings are less because these are available in long lengths</li> <li>2. The pipes are cheap in first cost</li> <li>3. The pipes are durable and strong enough to resist high internal water pressure</li> <li>4. The pipes are flexible to some extent and they can therefore laid on curves</li> <li>5. Transportation is easy because of light weight.</li> </ol>	<ol style="list-style-type: none"> <li>1. Maintenance cost is high</li> <li>2. The pipes are likely to be rusted by acidic or alkaline water</li> <li>3. The pipes require more time for repairs during breakdown and hence not suitable for distribution pipes</li> <li>4. The pipes may deform in shape under combined action of external forces</li> </ol>
3.	Prestressed concrete pipes	<ol style="list-style-type: none"> <li>1. The inside surface of pipes can be made smooth</li> <li>2. Maintenance cost is low</li> <li>3. The pipes are durable with life period 75 years</li> <li>4. No danger of rusting</li> <li>5. These pipes donot collapse or fail under normal traffic</li> </ol>	<ol style="list-style-type: none"> <li>1. The pipes are heavy and difficult to transport</li> <li>2. Repairs of these pipes are difficult</li> <li>3. The pipes are likely to crack during transport and handling operations</li> <li>4. There pipes are affected by acids, alkalies and salty</li> </ol>

		loads	waters.
4.	R.C.C Pipes	<ol style="list-style-type: none"> <li>1. There are pipes are most durable with usual life of about 75 years</li> <li>2. The pipes can cast at site work and thus there is reduction in transport charges</li> <li>3. Maintenance cost is less</li> <li>4. Inside surface of pipe can made smooth</li> <li>5. No danger of rusting.</li> </ol>	<ol style="list-style-type: none"> <li>1. Transportation is difficult</li> <li>2. Repair work is difficult</li> <li>3. Initial cost is high</li> <li>4. These pipes are affected by acids, alkalies and salty waters.</li> </ol>
5.	A.C. Pipes	<ol style="list-style-type: none"> <li>1. The inside surface of pipes are very smooth</li> <li>2. The joining of pipe is very good and flexible</li> <li>3. The pipes are anticorrosive and cheap in cost</li> <li>4. Light in weight and transport is easy</li> <li>5. The pipes are suitable for distribution pipes of small size.</li> </ol>	<ol style="list-style-type: none"> <li>1. The pipes are brittle and therefore handling is difficult</li> <li>2. The pipes are not durable</li> <li>3. The pipes cannot be laid in exposed places</li> <li>4. The pipes can be used only for very low pressures</li> </ol>
6.	Galvanised Iron pipes	<ol style="list-style-type: none"> <li>1. The pipes are cheap</li> <li>2. Light in weight and easy to handle</li> <li>3. The pipes are easy to jion</li> </ol>	<ol style="list-style-type: none"> <li>1. The pipes are affected by acidic or alkaline waters</li> <li>2. The useful life of pipes is short about 7 to 10 years.</li> </ol>
7.	P.V.C. Pipes	<ol style="list-style-type: none"> <li>1. Pipes are cheap</li> <li>2. The pipes are durable</li> <li>3. The pipes are flexible</li> <li>4. The pipes are free from corrosion</li> <li>5. The pipes are good electric insulators</li> <li>6. The pipes are light in weight and it can easy to mould any shape</li> </ol>	<ol style="list-style-type: none"> <li>1. The co-effcient of expansion for plastic is high</li> <li>2. It is difficult to obtain the plastic pipes of uniform composition</li> <li>3. The pipes are less resistance to heat</li> <li>4. Sometypes of plastic impart taste to the water.</li> </ol>



### 6.6.2 LAYING AND TESTING

Pipelines carrying water are laid 0.6m to 1m below the ground surface. Just before covering the trench with the earth, the pipe joints are to be tested for leakage. Joints are inspected visually during the test and relaid wherever required.

Pressure of pumping mains are tested for 1 1/2 times the operating pressure in the pipe for 24 hours . The pressure is increased gradually at the rate of 1kg/cm<sup>2</sup>/minute. Loss of water by leakage is made up at not more than 0.1lit/mm of diameter of pipe per km per day for every 0.3N/mm<sup>2</sup> pressure applied.

Allowable leakage during test is calculated by a formula  $Q_L = ND\sqrt{p} / 115$

Where  $Q_L \rightarrow$  Allowable leakage in lit/day

$N \rightarrow$  No. of joints

$P \rightarrow$  Average test pressure

$D \rightarrow$  diameter of pipe in mm

The above value is applicable for C.I A.C and concrete pipes. For steel and prestressed concrete pipes 3 times the above value is allowed.

Gravity pipes are tested with hydrostatic head of 2.5m at the highest point in the pipe for 10minutes permissible leakage is 0.2 litres / mm of diameter pipe per day per kilometer length.

### 6.6.3 MAINTENANCE OF PIPES

Hygienic quality and adequate flow in the pipe lines are to be maintained, preventive maintenance of pipes includes the following

1. Detection of leaks in faulty joints ferrule connections, pipes and fittings inside the consumer premises,
2. Detection of corrosion in pipes, fractures and replacement of these portions
3. The wastage of water 15 to 25% of leakage through pipe joints should be brought down to the minimum possible extent by adopting suitable preventive measures
4. Cleaning of pipes by flushing and disinfection of pipes
5. Protection against pollution

6. The records of regarding the lengths of pipe laid, length of pipe repaired or replaced, expenditure incurred, no. of fire hydrants , no. of service connections and all other relevant data inconnection with the distribution system should maintained for ready reference.

#### **6.6.4 PIPE CORROSION – CAUSES AND PREVENTION**

The term pipe corrosion is used to indicate the loss of pipe material due to action of water (Internal pipe corrosion) and action of water logged soil above the pipe surface (external pipe corrosion) by the results of corrosion, troublesome to both the water authority and consumers. The various factors contributing to the pipe corrosion are

1. **ACIDITY:** The water having low PH value due to the presence of carbonic acid or other acids may cause corrosion
2. **ALKALINITY:** The water possessing sufficient calcium bicarbonate alkalinity is anti-corrosive in nature
3. **BIOLOGICAL ACTION:** The growth of iron-bacteria, and sulphur bacteria may develop aerobic and anaerobic corrosion respectively.
4. **CHLORINATION:** The presence of free chlorine or chloramines makes the water corrosive
5. **ELECTRICAL CURRENTS:** Corrosion canals also be developed by the union of dissimilar metals or by the earthing of electrical system to water pipes.
6. **MINERAL AND ORGANIC CONSTITUENTS:** The presence of high total solids in water accelerates the process of corrosion
7. **OXYGEN:** the presence of oxygen is found in both the corrosive and non-corrosive waters. The aeration in fact is employed in some cases for prevention of corrosion.

#### **EFFECTS OF PIPE CORROSION**

1. Pipe corrosion may lead to the tuberculation (formation of small projections on the inside surface of pipe) which decreases carrying capacity of water
2. The pipe corrosion leads to the disintegration of pipeline and it demands heavy repairs
3. The pipe corrosion imparts colour, taste and odour to the flowing water
4. The pipe connections are seriously affected by pipe corrosion
5. The pipe corrosion may make the water dangerous for drinking and other purposes.

## PREVENTION OF PIPE CORROSION

Pipe corrosion is not possible to completely eliminate but we can minimise by the following methods.

1. **Cathodic protection:** By connecting the pipe line to the negative pole of D.C. generator or to the anode metals like magnesium so that the entire pipe acts as cathode. This cathodic treatment is most effective. It is expensive and involves many practical problems
2. **Proper pipe material:** The alloys of Iron or steel with chromium, copper or nickel are found to be more resistance
3. **Protective Linings:** The pipe surface should be coated with asphalt, bitumen, cement mortar, paints, resins, tar, zinc etc.
4. **Treatment of water:** By proper treatment and adjustment of PH value, control of calcium carbonate, removal dissolved oxygen and carbon dioxide, addition of sodium silicate etc prevent the pipe corrosion.

## SUMMARY

1. System of distribution are
  - a) Gravity supply system
  - b) Pumping supply system
  - c) Combined gravity and pumping system
2. The system of supply are
  - a) Continuous system
  - b) Intermittent system
3. The types of layout of distribution are
  - a) Dead-end system
  - b) Grid Iron system
  - c) Circular or ring system
  - d) Radial system
4. Power or energy required per second to the pump water is  $P_w = QH$  kw . Horse power of the pump is  $P_w \times 1.341$  HP
5. Points to be consider in selecting a pump are
  - a) Capacity
  - b) Lift
  - c) Total head
  - d) Cost

6. Pumps convert electrical energy supplied into pressure energy of water
7. Main components of a centrifugal pump are
  - a) Foot valve
  - b) Suction pipe
  - c) Delivery pipe
  - d) Gate valve
  - e) Reflux valve
  - f) Impellor
  - g) Casing
8. Requirements of pipe material to convey water are
  - a) Shall be cheap, durable, easy to transport and join
  - b) Shall withstand high pressure
  - c) Shall offer least frictional resistance to flow.
9. Types of pipes used are
  - a) C.I
  - b) Steel
  - c) Pre-stressed cement concrete
  - d) R.C.C.
  - e) A.C.
  - f) G.I.
  - g) P.V.C
10. Pipes are laid and tested for leakage and pressure allowable leakage is

$$Q_L = \frac{ND\sqrt{P}}{115} \quad \text{where}$$

$Q_L$  → Allowable leakage in lit/day

$D$  → Diameter of pipe in mm

$N$  → No. of joints

$P$  → Average test pressure in  $\text{kg/cm}^2$

### SHORT ANSWER QUESTIONS

1. Name the different layouts of distribution of water.
2. List any three types of pipe materials used as water mains.
3. List two advantages of P.V.C. pipes over steel pipes for water supply.
4. What is intermittent system of water supply?
5. List any three requirements of pipe material to convey water.
6. Name any four factors which causes the pipe corrosion.
7. Name any two effects of pipe corrosion.
8. Name the two systems of water supply.
9. Name any four methods of prevention of pipe corrosion.
10. What is the principle of centrifugal pump?
11. What is priming of pump?
12. List the spares to be stored for maintaing centrifugal pump.

### ESSAY TYPE QUESTIONS

1. What are the requirements of a distribution system?
2. List out the different types of layouts of city water distribution system.
3. Discuss the methods of distribution of water supply.
4. What are advantages and disadvantages of different types of pipe material used in the water supply distribution system?
5. What are the requirements of pipe material?
6. What are the methods of selecting a pump?
7. Draw the neat sketch of centrifugal pump and explain operation
8. What are the points to be observed in selecting a pump?
9. Explain the causes and effects of pipe corrosion.
10. What are the methods of prevention of pipe corrosion?

## CHAPTER 7

### APPURTENANCES IN THE DISTRIBUTION SYSTEM

#### **7.0 UNDERSTAND THE VARIOUS APPURTENANCES IN A DISTRIBUTION SYSTEM**

The various devices fixed along the water distribution system are known as appurtenances.

The necessity of the various appurtenances in distribution system are as follows

1. To control the rate of flow of water
2. To release or admit air into pipeline according to the situation
3. To prevent or detect leakages
4. To meet the demand during emergency and
5. Ultimately to improve the efficiency of the distribution

The following are the some of the fixtures used in the distribution system.

- (i) Valves
- (ii) Fire hydrants and
- (iii) Water meter

#### **7.1 TYPES OF VALVES**

In water works practice, to control the flow of water, to regulate pressure, to release or to admit air, prevent flow of water in opposite direction valves are required.

The following are the various types of valves named to suit their function

1. Sluice valves
2. Check valves or reflex valves
3. Air valves
4. drain valves or Blow off valves
5. Scour valve

### 7.2.1 SLUICE VALVES

These are also known as gate-valves or stop valves. These valve control the flow of water through pipes. These valves are cheaper, offers less resistance to the flow of water than other valves. The entire distribution system is divided into blocks by providing these valves at appropriate places. They are provided in straight pipeline at 150-200m intervals. When two pipes lines intersect, valves are fixed in both sides of intersection. When sluice valve is closed, it shuts off water in a pipeline to enable to undertake repairs in that particular block. The flow of water can be controlled by raising or lowering the handle or wheel.

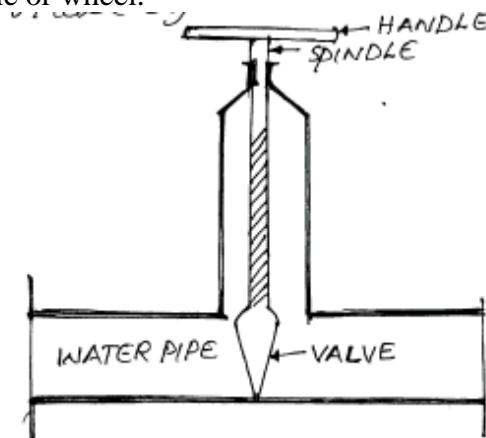

Fig 7.1

### 7.2.2 CHECK VALVE or REFLUX VALVE

These valves are also known as non-return valves. A reflux valve is an automatic device which allows water to go in one direction only. The swing type of reflux valve as shown in fig 7.2 is widely used in practice.

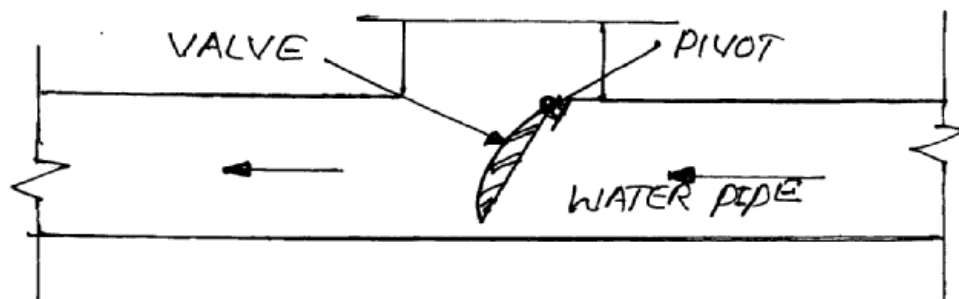

Fig 7.2

When the water moves in the direction of arrow, the valve swings or rotates around the pivot and it is kept in open position due to the pressure of water. When the flow of water in this direction ceases, the water tries to flow in a backward direction. But this valve prevents passage of water in the reverse direction.

Reflux valve is invariably placed in water pipe, which obtain water directly from pump. When pump fails or stops, the water will not run back to the pump and thus pumping equipments will be saved from damage.

### 7.2.3 AIR VALVES

These are automatic valves and are of two types namely

1. Air inlet valves
2. Air relief valves

#### 1. AIR INLET VALVES

These valves open automatically and allow air to enter into the pipeline so that the development of negative pressure can be avoided in the pipelines. The vacuum pressure created in the down streamside in pipelines due to sudden closure of sluice valves. This situation can be avoided by using the air inlet valves.

#### 2. AIR RELIEF VALVES

Some times air is accumulated at the summit of pipelines and blocks the flow of water due to air lock. In such cases the accumulated air has to be removed from the pipe lines. This is done automatically by means of air relief valves.

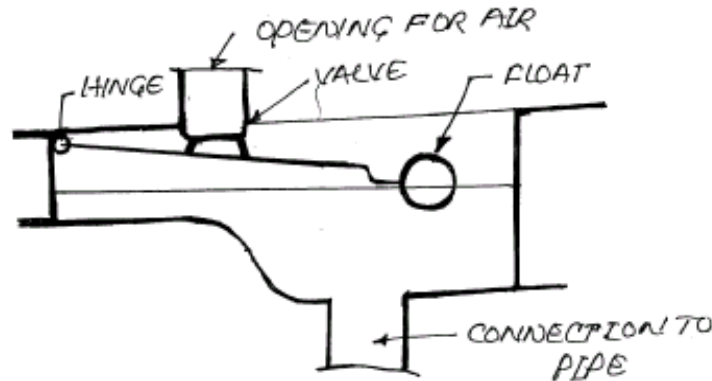

Fig 7.3. Air Valve

This valve consists of a chamber in which one or two floats are placed and is connected to the pipe line. When there is flow under pressure in the pipeline water occupies the float chamber and makes the float to close the outlet. But where there is accumulation of air in the pipeline, air enters the chamber, makes the float to come down, thus opening the outlet. The accumulated air is driven out through the outlet.



#### **7.2.4 DRAIN VALVES OR BLOW OFF VALVES**

These are also called wash out valves they are provided at all dead ends and depression of pipelines to drain out the waste water. These are ordinary valves operated by hand.

#### **7.2.5. SCOUR VALVES**

These are similar to blow off valves. They are ordinary valves operated by hand. They are located at the depressions and dead ends to remove the accumulated silt and sand. After the complete removal of silt; the value is to be closed.

#### **7.2.6. WATER METER**

These are the devices which are installed on the pipes to measure the quantity of water flowing at a particular point along the pipe. The readings obtained from the meters help in working out the quantity of water supplied and thus the consumers can be charged accordingly. The water meters are usually installed to supply water to industries, hotels, big institutions etc. metering prevents the wastage of purified water.

#### **7.2.7 FIRE HYDRANTS**

A hydrant is an outlet provided in water pipe for tapping water mainly in case of fire. They are located at 100 to 150 m a part along the roads and also at junction roads. They are of two types namely.

1. Flush Hydrants.
2. Post Hydrants

##### **1. Flush Hydrants**

The flush hydrants is kept in under ground chamber flush with footpath covered by C.I. cover carrying a sign board “F-H”.

##### **2. Post Hydrants**

The post hydrant remain projected 60 to 90cm above ground level as shown in fig 7.4 They have long stem with screw and nut to regulate the flow. In case of fire accident , the fire fighting squad connect their hose to the hydrant and draw the water and spray it on fire.

A good fire hydrant

1. Should be cheap
2. Easy to connect with hose
3. Easily detachable and reliable

4. Should draw large quantity of water

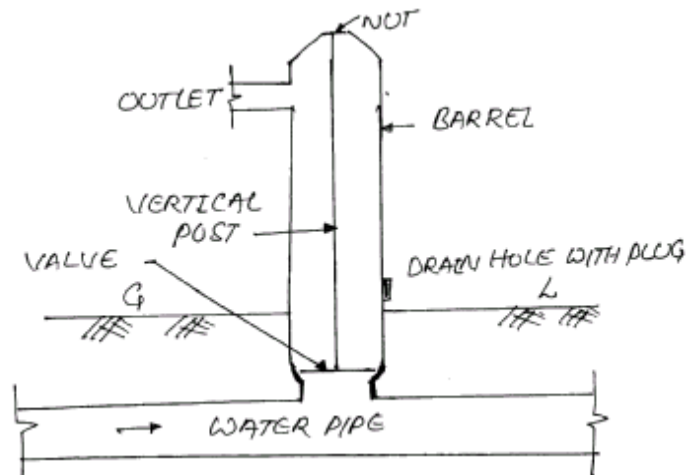

**Fig 7.4 POST FIRE HYDRANT**

### SUMMARY

1. The various devices fixed along the water distribution system are known as appurtenances.
2. They are used
  - a) To control the rate of flow
  - b) To release or admit air into pipe line
  - c) To draw water for fire fighting and
  - d) Ultimately to improve the efficiency of the distribution system
3. Some the appurtenances are
  - b) Valves
  - c) Fire hydrants
  - d) Watermeter
4. The types of valves are
  - b) Sluice valve
  - c) Check or Reflux valve
  - d) Air valve
  - e) Drain valve or blow off valve
  - f) Scour valve
5. Sluice valves or gate valve is used to control the flow of water.
6. Check or reflex valve is used to allow water to flow in one direction only
7. Air valves are automatic valves and are two types
  - b) Air inlet valves – opens automatically and allow air to enter into the pipeline to avoid negative pressures

- c) Air-relief valve – are fixed at summit of pipeline to remove accumulated air to avoid air lock
8. Drawn valve or blow off valve or wash out valve provided at all dead ends and depressions of pipeline to drawn out the wash water.
  9. Scour valve is similar to blow off valve is located at the depressions and dead ends to remove the accumulated silt and sand
  10. Fire hydrants are the mountings on the water mains and distribution pipes to draw large quantity of water for fire fighting purpose. Fire hydrants are of two types.
    - b) Flush hydrant is kept in underground chamber flush with footpath covered by C.I. cover carrying sign board “F-H”.
    - c) The post hydrant remain projected 60 to 90 cm above ground level.
  11. A water meter is a device used for measuring the amount of water flowing through it.

**SHORT ANSWER TYPE QUESTIONS**

1. What are the appurtenances used in the distribution system?
2. Mention the function of sluice valve?
3. What is the function of drain or blow off valve?
4. Where is the scour valve is fixed?
5. Name any four types of valves?
6. What is the purpose of air valves?
7. Mention the purpose of water meter.
8. What is the purpose of fire hydrants in the water distribution system?
9. What are the requirements of good fire hydrant?
10. What is the function of the reflux valve?

**ESSAY ANSWER TYPE QUESTIONS**

1. Draw a neat sketch of sluice valve and explain.
2. Mention any four appurtenances used in water distribution system and explain their functions.
3. With the help of neat sketch explain the function of check valve.
4. Draw the neat sketch of air-relief valve and explain the function.
5. With the help of neat sketch, describe the post fire hydrant.
6. Write short notes on any two of the following.
  - a) Water meter
  - b) Drain valve
  - c) Scour valve
7. Write short notes on the following.
  - a) Fire hydrants
  - b) Air valves.

**CHAPTER 8**  
**WATER SUPPLY PLUMBING SYSTEMS**  
**IN BUILDING AND HOUSES**

It is necessary to know the following terms relating to plumbing, principles and the common practices used in the house plumbing

1. Water main: A water supply pipe vests in the administrative authority for the use of public or community
2. Ferrule: It is gunmetal or bronze screwed into the hole drilled in CI pipe mains. Communication pipe takes off from the ferrule. The pressure in the domestic supply and equal distribution among the house connection are effected by adjusting the ferrule opening. Normally the ferrule opening is equal in area to the area of flow in communication pipe.
3. Saddle: it is used in place of ferrule for mains of AC or PVC pipes
4. Communication pipes: It is a pipe taking off from the ferrule for the house connection. It is owned and managed by the water supply authority. Communication pipe terminates at the boundary of the consumers premises.
5. Service pipe : it is the part of the house connection beyond the stop cock. It is owned and maintained by the consumer . No pumps shall be installed on this pipe.
6. Watermeter: It is installed to measure the flow. It is an integrating meter that it records the total flow upto the time of measurement.

Generally 12.5 mm to 18.75mm rotary water meters are installed either at the beginning or at the middle of the service pipe. A masonry pit is constructed around it. It has facility of sealing by the water supply authority

7. Residual pressure: It is generally measured at the ferrule and should be about 7m head of water
8. Goose Nech: It is the short bent pipe and allow for small changes in length due to expansion and movement of pipes due to soil settlements

**8.1. PLUMBING SYSTEMS IN WATER SUPPLIES**

The following are the requirements of plumbing systems in water supplies

1. Plumbing of water lines should be such as not to permit back flow from eistern and sinks

2. All joints shall be perfectly water tight and no leakage or spill at taps or cocks should be allowed
3. Pipelines should not be carried under walls or foundations
4. It should not be close to sewers or waste water drains. There should not be any possibility for cross connections.
5. When pipe lines are close to electric cables proper precautions for insulation should be observed
6. plumbing lines should be such as to afford easy inspection and repair of fixtures and joints.
7. Number of joints should be less and the number of bends and tees should be less
8. It should supply adequate discharge at fixtures economical in terms of material and protected against corrosion , air lock, negative pressure and noise due to flow in pipes and in flushing

## 8.2. THE HOUSE WATER CONNECTIONS

The house water connection is as shown in the fig 8.1

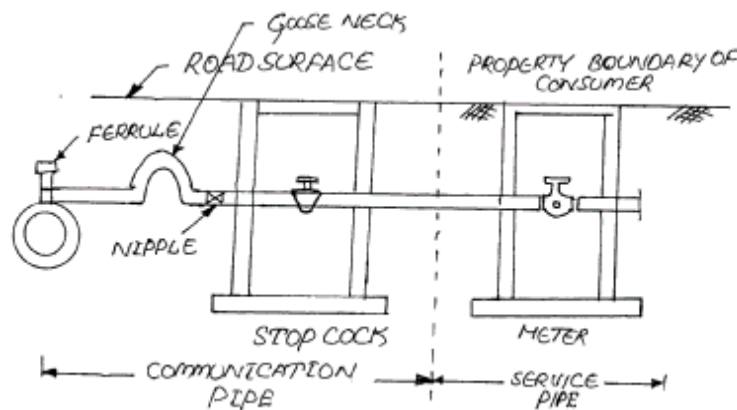

**Fig 8.1 House water connection**

## 8.3 STOP COCKS

It is a valve fitted at the end of communication pipe and it is under the control of water supply authority. The purpose of stop cock is to stop the supply of water. Temporary disconnections are made at the stopcock while permanent disconnections are made at ferrule. The stop cock is as shown in fig 8.2

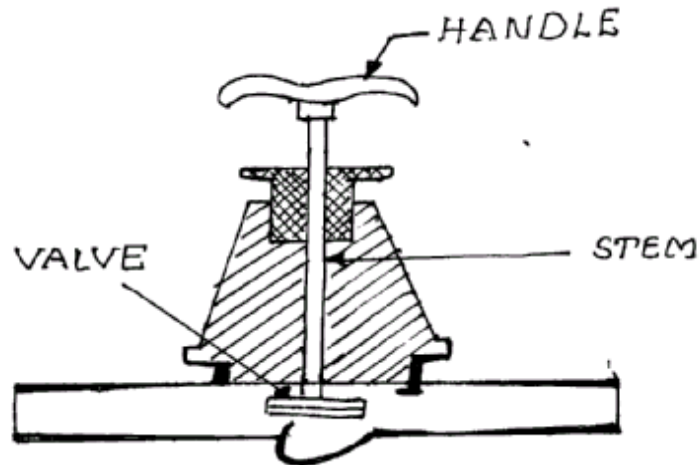
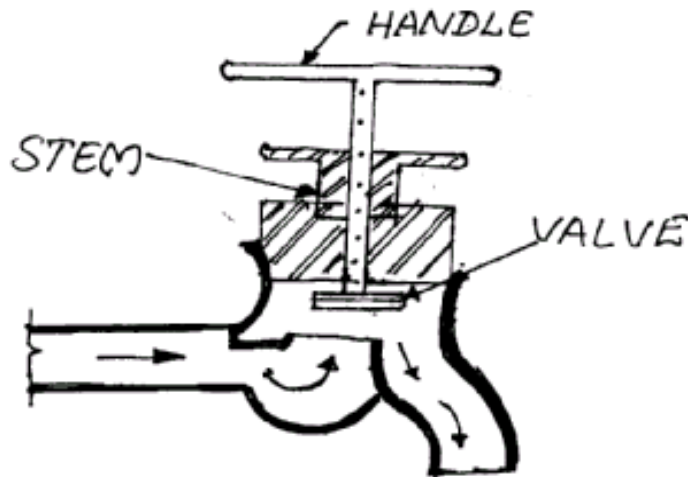

**Fig 8.2 Stop Cock**

**8.4 WATER TAPS OR BIB COCKS**

These are the water taps which are attached at the end of water pipes and from which the consumers obtained water. It is operated from a handle, the water comes out from the opening. The bibcocks may also be of push type and they operate automatic.

The bibcocks should be water tight. The leaky bib cocks are the source of waste of water. Fig 8.3 shows typical bobcock and table 8.1. gives the idea of water lost due to leaky bibcocks in continuous system of water supply. Therefore it is advisable to repair or replace such leaky bib cocks as early as possible



**Fig 8.3 Bib Cock**

S.No.	Leakage	Loss of water in litres per day
1.	30 drops per minute	8
2.	60 drops per minute	17
3.	120 drops per minute	36
4.	13mm deep solid stream	153
5.	38mm deep solid stream	333

**Table 8.1 LOSS OF WATER DUE TO LEAKY BIB COCKS**

**8.5 PIPE FITTINGS**

In addition to the pipes, valves, tapes, various types of pipe fittings such as unions, caps, plugs, flanges, nipples, crosses, tees, elbows, bends etc are used during laying of distribution pipes. The common pipe fittings are shown in fig 8.4

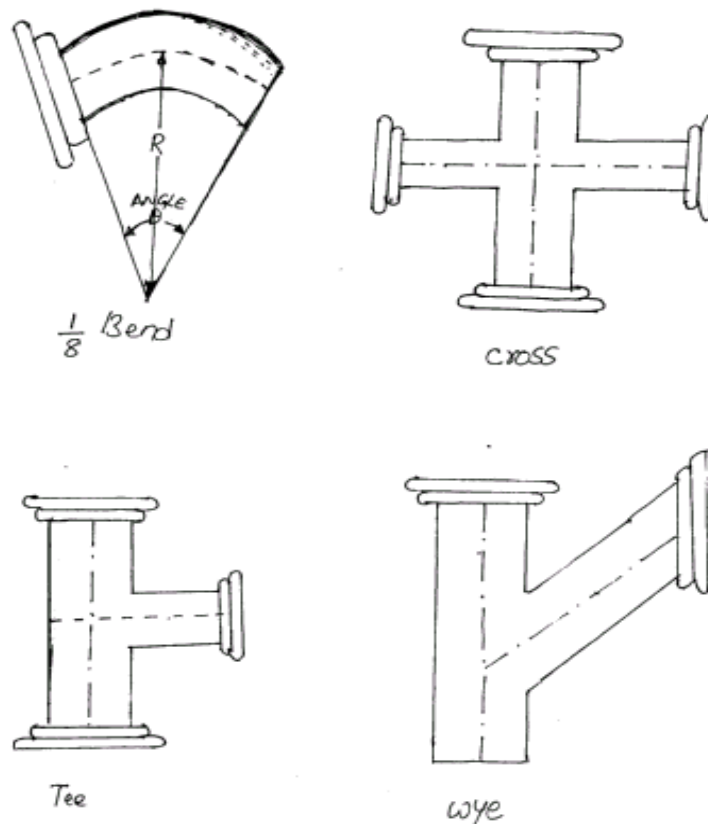

**Fig 8.4 Pipe Fittings**



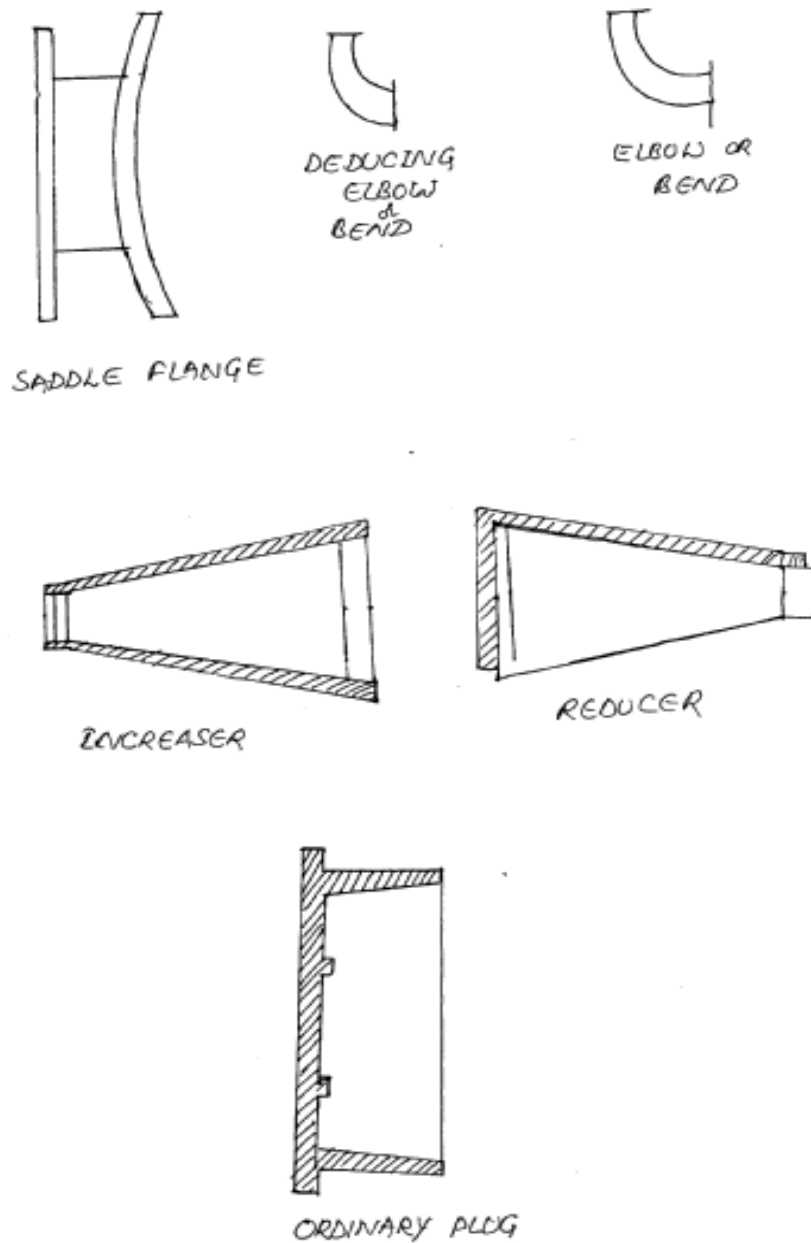

**Fig 8.4 Pipe Fittings**

### **8.6. STORAGE OF WATER IN BUILDINGS**

In the buildings, the storage of water is required for the following purposes

1. For supplying the water to the consumers during non-supply hours
2. For reducing the maximum rate of demand on the water mains
3. For storage of watering during interruption to damage repair etc of the water mains

4. When the available head is insufficient to supply the water in each storey in multi storey buildings

The storage of water in buildings are constructed of cast Iron, wrought iron, galvanized mild steel plates or R.C.C. storage tanks. Storage tanks may be kept on the roof of the building or on the ground and should be water-tight . The storage tank should be placed in such a position so that the discharge of water can be readily seen. The tank should be provided with overflow pipe and drain pipe near the bottom to clean the tank. The storage tanks are provided with outlet pipes to draw the water.

### 8.6.1 ESTIMATING STORAGE CAPACITY

The quantity of water to be stored depends on the following factors.

- a) Rate of supply of water from water works
- b) Type of building such as residential, public or industrial
- c) Wheather water supply is continuous or intermittent
- d) Frequency replenishment of overhead tanks, during the 24 hours

As per IS 2065-1963 the storage capacities are given in the table 8.2 and table 8.3.

Sl.No.	Classification of buildings	Storage capacities
1.	For tenements having common conveniences	900lit net per w.c. seat
2.	For residential premises other than tenements having common conveniences	270lit net for w.c. seat and 180lit for each additional w.c. seat in the same flat
3.	For factories and workshops	900lit per w.c. seat and 180 lit per urinal seat
4.	For cinemas , public assembly halls etc.	900lit per w.c. seat and 350 lit per urinal seat

**Table 8.2 Flushing Storage Capacity**

Sl.No.	Floor	Storage	Remarks
	For premises occupied tenements with common conveniences		
1.	Ground floor	Nil	Providing no downtake fitting installed
2.	1st , 2 <sup>nd</sup> , 3 <sup>rd</sup> , 4 <sup>th</sup> and upper floors	500 lit per tenement	
	For premises occupied as flats of block		Provided no downtake fitting are installed
1.	Ground floor	Nil	
2.	1st , 2 <sup>nd</sup> , 3 <sup>rd</sup> , 4 <sup>th</sup> and upper floors	8000 lit per tenement	

**Table 8.3 Domestic Storage Capacities**

**8.6.2 OVERHEAD STORAGE, UNDER GROUND STORAGE TANKS**

When water is to be distributed at very high pressure elevated tanks may be constructed with steel or R.C.C. R.C.C elevated tanks are very popular because 1. Long life 2. Little maintenance 3. Decent appearance

Recently prestressed R.C.C. tanks are coming up, because they are even economical than plain R.C.C tanks. All the overhead tanks are provided with inlet, outlet, drain pipe, overflow pipe, water level indicator, manhole, ladder, ventilating pipe, lightning conductor etc. About 60 to 100cm wide balcony is provided around the tank for inspection and maintenance of the tank. These tanks can store large quantity of water as shown in the fig 8.5

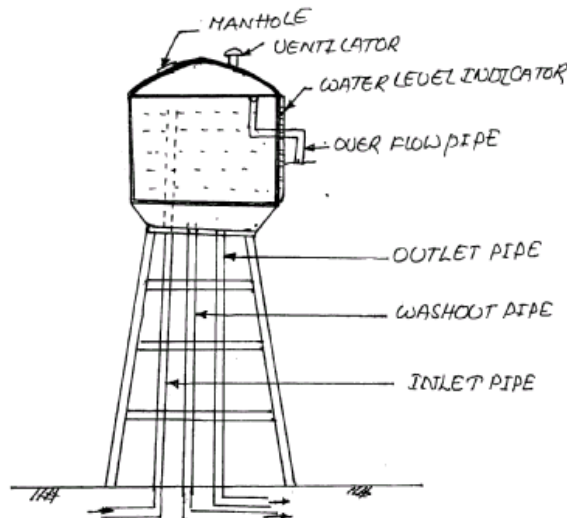

**Fig 8.5. Overhead Tank**

## UNDER GROUND STORAGE RESERVOIR

These reservoirs are used for storing and distributing clear water. These reservoirs are constructed on high natural grounds and are usually made of stones, bricks, plain or reinforced cement concrete. The side walls are designed to take up the pressure of the water, when the reservoir is full and the earth pressure when it is empty. The position of ground water table is also considered while designing these reservoirs. The floors of these reservoirs may be constructed with R.C.C slab or square stone blocks resting on columns. To obtain water tightness bitumen compounds are used at all construction joints. At the top of roof about 60cm thick earth layer is deposited and maintained green lawns to protect the reservoir from cold and heat. For aeration of water and inspection, ventilation pipes and stairs are provided respectively as shown in fig 8.6.

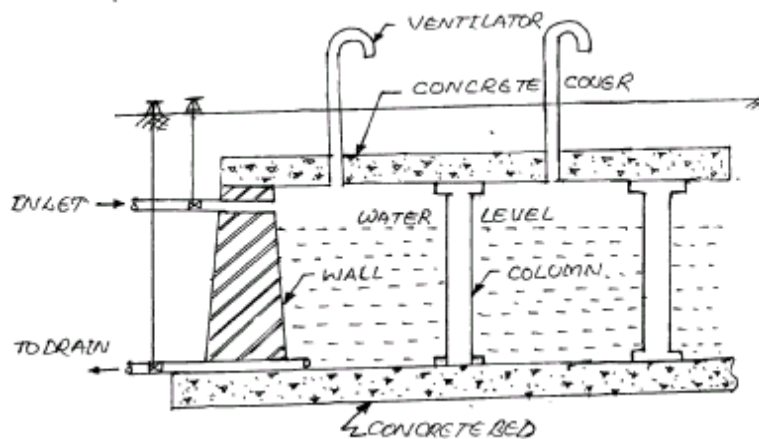

Fig 8.6. Under Ground Reservoir

### 8.6.3 TYPES OF TANKS

- a) **R.C.C TANKS:** R.C.C tanks are very popular because
  - 1) They have long life
  - 2) Very little maintenance
  - 3) decent appearance
- b) **G.I. TANKS:** G.I. tanks are generally in rectangular or square in shape. Now a days G.I. tanks are not preferring because
  - 1) Life of the tank is short
  - 2) Corrosion of metal
  - 3) maintenance cost may be more
- c) **HDPE TANKS:** Now a days HDPE tanks are very popular for storing less quantity of water and hence useful for residential purpose. The following are the advantages of HDPE tanks
  - 1) Handling is easy because of light weight
  - 2) Cheap in cost
  - 3) Maintenance cost is low
  - 4) Cleaning of tanks are easy

#### **8.6.4 GENERAL REQUIREMENT OF DOMESTIC WATER STORAGE**

- 1) To store the treated water till it is distributed to the city
- 2) To absorb the hourly variations in the water demand and thus allowing the treatment units and pumps to work at the average constant rate. This will reduce operation & maintenance cost of treatment as well as improve their efficiency
- 3) For meeting the water demands during fires
- 4) In case of breakdown of pumps, repair the storage reservoir will provide water

#### **8.7 WATER PIPING SYSTEM IN BUILDING**

**The following are the requirements of piping system in building**

1. Plumbing of water lines should be such as not to permit backflow from cisterns and sinks.
2. All joints shall be perfectly water tight and no leakage or spill at taps or cocks should be allowed.
3. Pipelines should not be carried under walls or foundations
4. It should not be close to sewers or waste water drains. There should not be any possibility for cross connections
5. When pipelines are close to electric cables proper precautions for insulation should be observed
6. Plumbing lines should be such as to afford easy inspection and repair of fixtures and joints
7. Number of joints should be less and number of bends and tees should be less
8. It should supply adequate discharge at fixtures, economical in terms of materials and protected against corrosion, airlock, negative pressure and noise due to flow in pipes and in flushing.

##### **8.7.1 PIPING SYSTEM USING DIRECT SUPPLY**

When the residual pressure at the ferrule is greater than 7m and continuous supply is available in the mains, water may be supplied directly from the service pipe for various fixtures for a single storey building.

### **8.7.2 PIPING SYSTEM USING OVER HEAD TANKS**

If the supply is intermittent and residual pressure is low then, water is pumped to over-head tanks and then supplied to distribution pipes at required pressure by gravity

### **8.7.3 PIPING SYSTEM USING UNDER GROUND AND OVER HEAD TANK SUPPLY (Down take water supply)**

If the supply is intermittent and residual pressure is low then a ground level storage tank and a overhead storage tank are built to supply water. Water from the overhead tank is drawn by down take pipes and then into the distribution pipes for fixtures.

### **8.7.4 PUMPED SYSTEMS**

When the residual pressure at the ferrule is less than 7m and continuous supply is available in the mains, water may be supplied by pumping from the service pipes.

## **SUMMARY**

1. Technical terms a) Water main b) Ferrule c) Stop cock d) Bib cock e) Residual pressure
2. The storage of building in a building may be a) Overhead tank b) Underground tank
3. The requirements of plumbing system in buildings are
  - a) Shall be free from leakages
  - b) Shall be easy to erect and inspect
  - c) Shall have minimum number of joints and economical
  - d) Shall be no back flow from cistern or sinks.
4. Indirect supply system all the fixtures in the building are supplied with adequate pressure from the supply main
5. In down take water supply water from the street mains collected in a ground level sump and then pumped up to overhead tanks on top of the building. All the overhead tank and distribution pipes.